

DATA SHEET

TDA3810

**Spatial, stereo and pseudo-stereo
sound circuit**

Product specification
File under Integrated Circuits, IC02

January 1985

Spatial, stereo and pseudo-stereo sound circuit

TDA3810

DESCRIPTION

The TDA3810 integrated circuit provides spatial, stereo and pseudo-stereo sound for radio and television equipment.

Features

- Three switched functions:
 - spatial (widened stereo image)
 - stereo
 - pseudo-stereo (artificial stereo from a mono source)
- Offset compensated operational amplifiers to reduce switch noise
- LED driver outputs to facilitate indication of selected operating mode
- Start/stop circuit to reduce switch noise and to prevent LED-flicker
- TTL-compatible control inputs

QUICK REFERENCE DATA

Supply voltage (pin 18)	V_P	typ.	12	V
Supply current (LEDs off)	I_P	typ.	6	mA
Operating ambient temperature range	T_{amb}		0 to +70	°C
Input signals (r.m.s. value)	$V_{i(rms)}$	<	2	V
Total harmonic distortion (stereo)	THD	typ.	0,1	%
Channel separation (stereo)	α	typ.	70	dB
Gain (stereo)	G_v	typ.	0	dB

PACKAGE OUTLINE

18-lead DIL; plastic (SOT102); SOT102-1; 1996 November 25.

Spatial, stereo and pseudo-stereo sound circuit

TDA3810

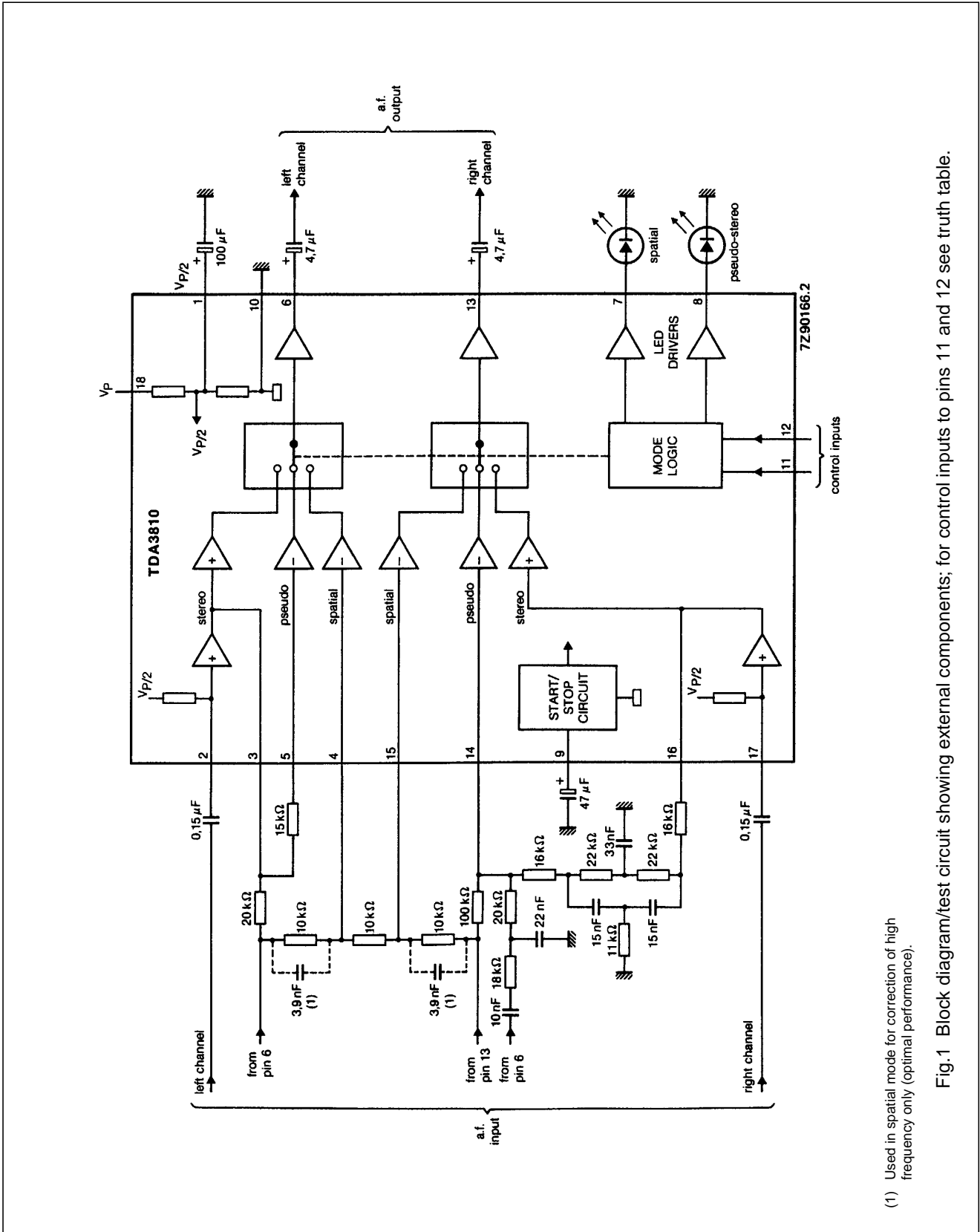

(1) Used in spatial mode for correction of high frequency only (optimal performance).
 Fig.1 Block diagram/test circuit showing external components; for control inputs to pins 11 and 12 see truth table.

Spatial, stereo and pseudo-stereo sound circuit

TDA3810

RATINGS

Limiting values in accordance with the Absolute Maximum System (IEC 134)

Supply voltage (pin 18)	V_P	max.	18	V
Storage temperature range	T_{stg}		-25 to +150	°C
Operating ambient temperature range	T_{amb}		0 to +70	°C

THERMAL RESISTANCE

From crystal to ambient	$R_{th\ cr-a}$	=	80	K/W
-------------------------	----------------	---	----	-----

CHARACTERISTICS

 $V_P = 12\text{ V}$; $T_{amb} = 25\text{ °C}$; test circuit Fig.1 stereo mode (pin 11 to ground) unless otherwise specified.

Output load:

 $R_{6-10, 13-10} \geq 4,7\text{ k}\Omega$; $C_{6-10, 13-10} \leq 150\text{ pF}$.

PARAMETER	SYMBOL	MIN.	TYP.	MAX.	UNIT
Supply voltage range (pin 18)	V_P	4,5	–	16,5	V
Supply current	I_P	–	6	12	mA
Reference voltage	V_S	5,3	6	6,7	V
Input voltage (pin 2 or 17) THD = 0,2% (stereo mode)	$V_{i(rms)}$	–	–	2	V
Input resistance (pin 2 or 17)	R_i	50	75	–	k Ω
Voltage gain V_o/V_i	G_v	–	0	–	dB
Channel separation (R/L)	α	60	70	–	dB
Total harmonic distortion $f = 40\text{ to }16\ 000\text{ Hz}$; $V_{o(rms)} = 1\text{ V}$	THD	–	0,1	–	%
Power supply ripple rejection	RR	–	50	–	dB
Noise output voltage (unweighted) left and right output	$V_{n(rms)}$	–	10	–	μV
<i>SPATIAL MODE</i> (pins 11 and 12 HIGH)					
Antiphase crosstalk	α	–	50	–	%
Voltage gain	G_v	1,4	2,4	3,4	dB

PSEUDO-STEREO MODE

The quality and strength of the pseudo-stereo effect is determined by external filter components.

Spatial, stereo and pseudo-stereo sound circuit

TDA3810

PARAMETER	SYMBOL	MIN.	TYP.	MAX.	UNIT
<i>CONTROL INPUTS</i> (pins 11 and 12)					
Input resistance	R_i	70	120	–	$k\Omega$
Switching current	$-I_i$	–	35	100	μA
<i>LED DRIVERS</i> (pins 7 and 8)					
Output current for LED	$-I_o$	10	12	15	mA
Forward voltage	V_F	–	–	6	V

Truth table

MODE	CONTROL INPUT STATE		LED SPATIAL PIN 7	LED PSEUDO PIN 8
	PIN 11	PIN 12		
Mono pseudo-stereo	HIGH	LOW	off	on
Spatial stereo	HIGH	HIGH	on	off
Stereo	LOW	X	off	off

LOW = 0 to 0,8 V (the less positive voltage)

HIGH = 2 V to 5,5 V (the more positive voltage)

X = don't care

Spatial, stereo and pseudo-stereo sound circuit

TDA3810

PACKAGE OUTLINE

DIP18: plastic dual in-line package; 18 leads (300 mil)

SOT102-1

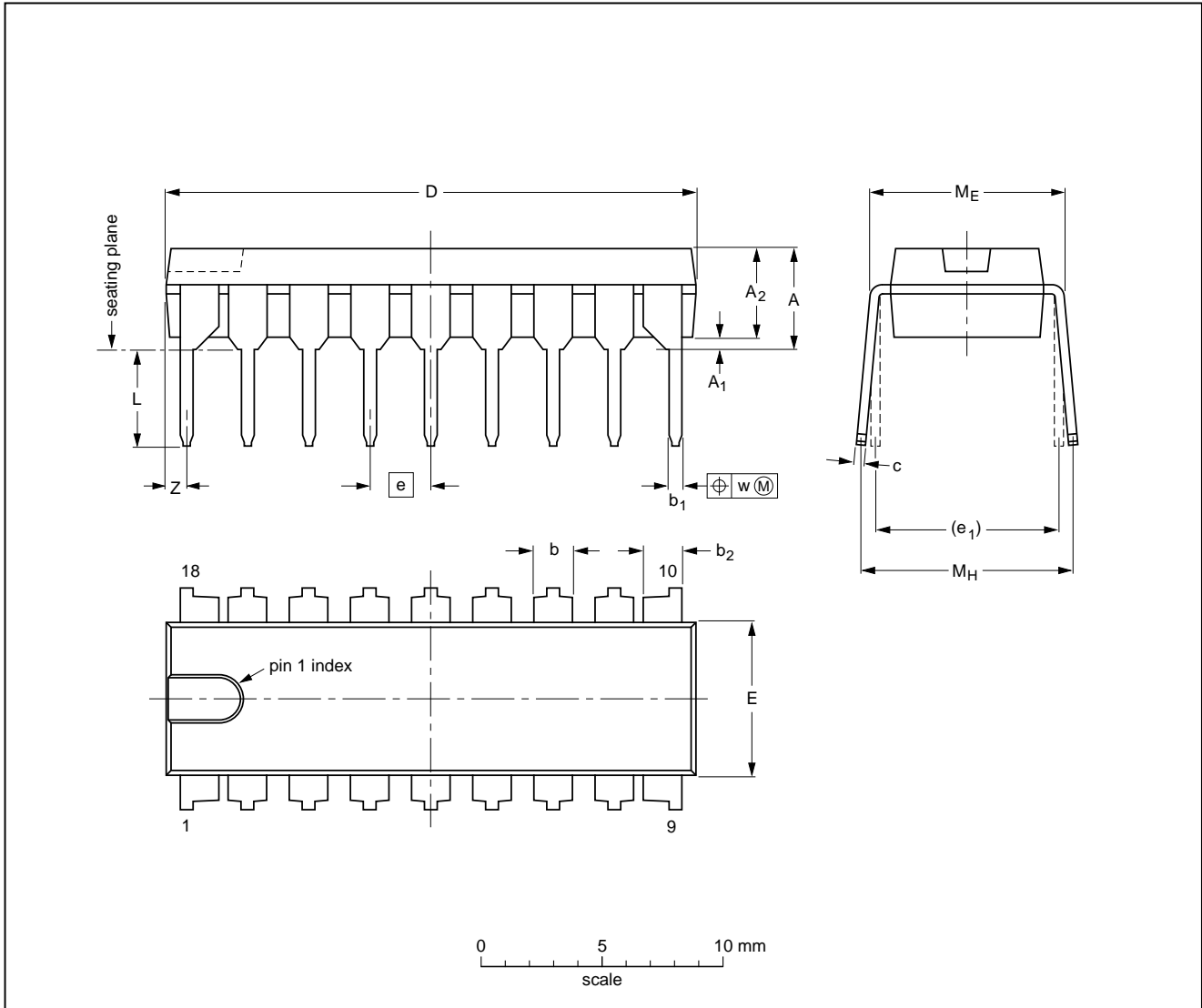

DIMENSIONS (inch dimensions are derived from the original mm dimensions)

UNIT	A max.	A ₁ min.	A ₂ max.	b	b ₁	b ₂	c	D ⁽¹⁾	E ⁽¹⁾	e	e ₁	L	M _E	M _H	w	Z ⁽¹⁾ max.
mm	4.7	0.51	3.7	1.40 1.14	0.53 0.38	1.40 1.14	0.32 0.23	21.8 21.4	6.48 6.20	2.54	7.62	3.9 3.4	8.25 7.80	9.5 8.3	0.254	0.85
inches	0.19	0.020	0.15	0.055 0.044	0.021 0.015	0.055 0.044	0.013 0.009	0.86 0.84	0.26 0.24	0.10	0.30	0.15 0.13	0.32 0.31	0.37 0.33	0.01	0.033

Note

1. Plastic or metal protrusions of 0.25 mm maximum per side are not included.

OUTLINE VERSION	REFERENCES				EUROPEAN PROJECTION	ISSUE DATE
	IEC	JEDEC	EIAJ			
SOT102-1						93-10-14 95-01-23

Spatial, stereo and pseudo-stereo sound circuit

TDA3810

SOLDERING

Introduction

There is no soldering method that is ideal for all IC packages. Wave soldering is often preferred when through-hole and surface mounted components are mixed on one printed-circuit board. However, wave soldering is not always suitable for surface mounted ICs, or for printed-circuits with high population densities. In these situations reflow soldering is often used.

This text gives a very brief insight to a complex technology. A more in-depth account of soldering ICs can be found in our "IC Package Databook" (order code 9398 652 90011).

Soldering by dipping or by wave

The maximum permissible temperature of the solder is 260 °C; solder at this temperature must not be in contact

with the joint for more than 5 seconds. The total contact time of successive solder waves must not exceed 5 seconds.

The device may be mounted up to the seating plane, but the temperature of the plastic body must not exceed the specified maximum storage temperature ($T_{stg\ max}$). If the printed-circuit board has been pre-heated, forced cooling may be necessary immediately after soldering to keep the temperature within the permissible limit.

Repairing soldered joints

Apply a low voltage soldering iron (less than 24 V) to the lead(s) of the package, below the seating plane or not more than 2 mm above it. If the temperature of the soldering iron bit is less than 300 °C it may remain in contact for up to 10 seconds. If the bit temperature is between 300 and 400 °C, contact may be up to 5 seconds.

DEFINITIONS

Data sheet status	
Objective specification	This data sheet contains target or goal specifications for product development.
Preliminary specification	This data sheet contains preliminary data; supplementary data may be published later.
Product specification	This data sheet contains final product specifications.
Limiting values	
Limiting values given are in accordance with the Absolute Maximum Rating System (IEC 134). Stress above one or more of the limiting values may cause permanent damage to the device. These are stress ratings only and operation of the device at these or at any other conditions above those given in the Characteristics sections of the specification is not implied. Exposure to limiting values for extended periods may affect device reliability.	
Application information	
Where application information is given, it is advisory and does not form part of the specification.	

LIFE SUPPORT APPLICATIONS

These products are not designed for use in life support appliances, devices, or systems where malfunction of these products can reasonably be expected to result in personal injury. Philips customers using or selling these products for use in such applications do so at their own risk and agree to fully indemnify Philips for any damages resulting from such improper use or sale.