

DATA SHEET

TDA7088T FM receiver circuit for battery supply

Product specification
Supersedes data of January 1991
File under Integrated Circuits, IC01

1996 May 14

FM receiver circuit for battery supply

TDA7088T

FEATURES

- Equipped with all stages of a mono receiver from antenna to audio output
- Mute circuit
- Search tuning with a single varicap diode
- Mechanical tuning with integrating AFC
- AM application supported
- Power supply polarity protection
- Power supply voltage down to 1.8 V.

APPLICATIONS

- Mechanical tuning; this is possible with or without integrating AFC circuit
- Electrical tuning; this is realized by one directional (band-up) search tuning facility, including RESET to the lower-band limit.

GENERAL DESCRIPTION

The TDA7088T is a bipolar integrated circuit for use in mono portable and pocket radios. It is used when a minimum of peripheral components (of small dimensions and low costs) is important. The circuit contains a frequency-locked-loop (FLL) system with an Intermediate Frequency (IF) of about 70 kHz. Selectivity is achieved by active RC-filters. De-tuning related to the IF and too weak input signals is suppressed by the mute circuit.

QUICK REFERENCE DATA

SYMBOL	PARAMETER	CONDITIONS	MIN.	TYP.	MAX.	UNIT
V_P	supply voltage		1.8	3	5	V
I_P	supply current		4.2	5.2	6.6	mA
f_{iRF}	radio input frequency		0.5	–	110	MHz
$V_{i(rms)}$	RF sensitivity input voltage (RMS value)	$V_{oAF} = -3$ dB; $V_{oAF} = 0$ dB at $V_i = 1$ mV; mute off	–	3	6	μ V
	signal handling	$\Delta f = \pm 75$ kHz; THD < 10%	100	200	–	mV
$V_{o(rms)}$	audio output signal (RMS value)	$R_L = 22$ k Ω	60	85	120	mV
T_{amb}	operating ambient temperature		-10	–	+70	$^{\circ}$ C

ORDERING INFORMATION

TYPE NUMBER	PACKAGE		
	NAME	DESCRIPTION	VERSION
TDA7088T	SO16	plastic small outline package; 16 leads; body width 3.9 mm	SOT109-1

FM receiver circuit for battery supply

TDA7088T

BLOCK DIAGRAM AND APPLICATION CIRCUIT

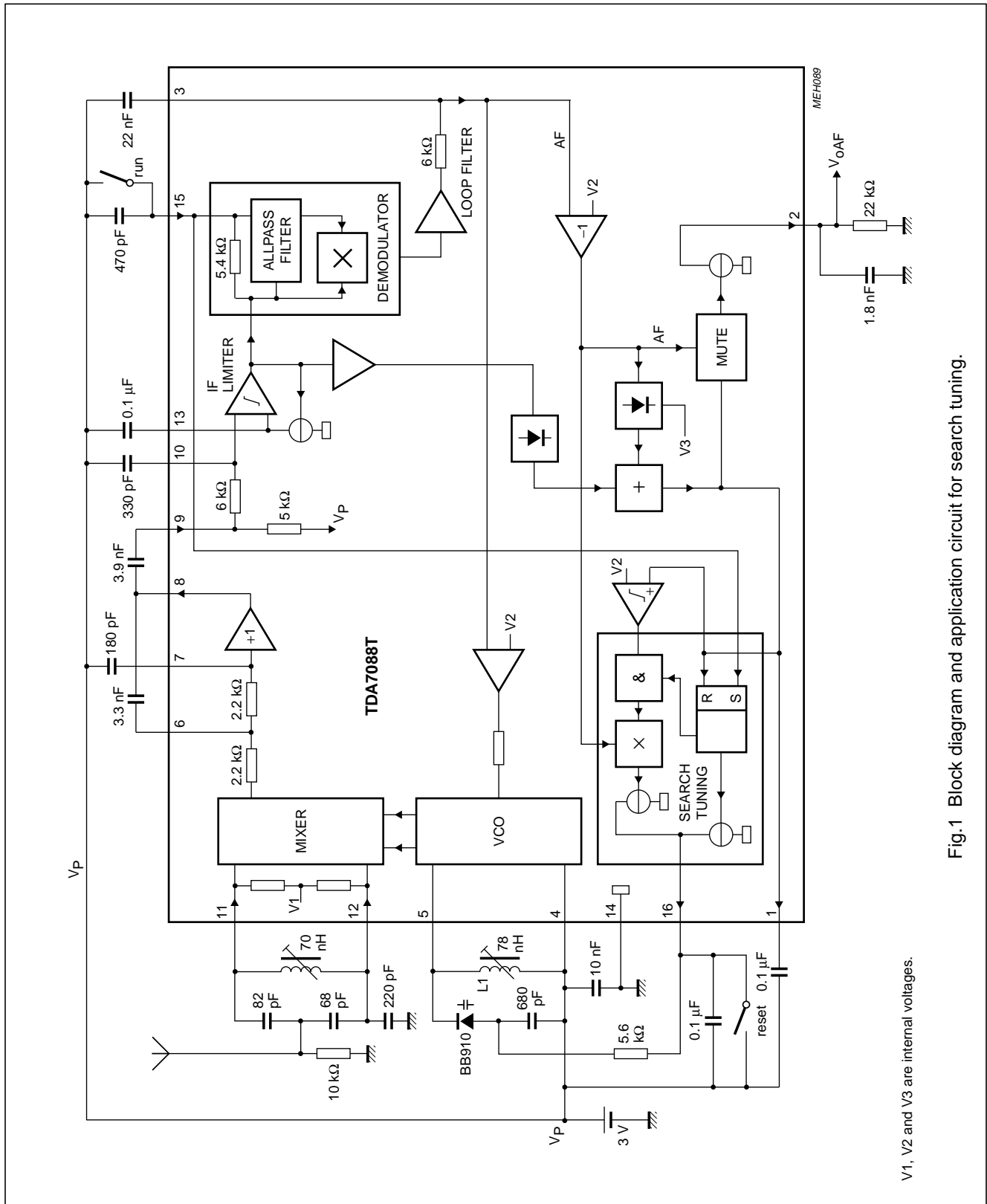

Fig.1 Block diagram and application circuit for search tuning.

V1, V2 and V3 are internal voltages.

FM receiver circuit for battery supply

TDA7088T

PINNING

SYMBOL	PIN	DESCRIPTION
MUTE	1	mute output
V _{oAF}	2	audio frequency output signal
LOOP	3	AF loop filter
V _P	4	+3 V supply voltage
OSC	5	oscillator resonant circuit
IFFB	6	IF feedback
C _{LP1}	7	low-pass capacitor of 1 dB amplifier
V _{oIF}	8	IF output to external coupling capacitor (high-pass)
V _{iIF}	9	IF input to limiter amplifier
C _{LP2}	10	low-pass capacitor of IF limiter amplifier
V _{iRF}	11	radio frequency input
V _{iRF}	12	radio frequency input
C _{LIM}	13	limiter offset voltage capacitor
GND	14	ground (0 V)
C _{AP}	15	all-pass filter capacitor/input for search tuning
TUNE	16	electrical tuning/AFC output

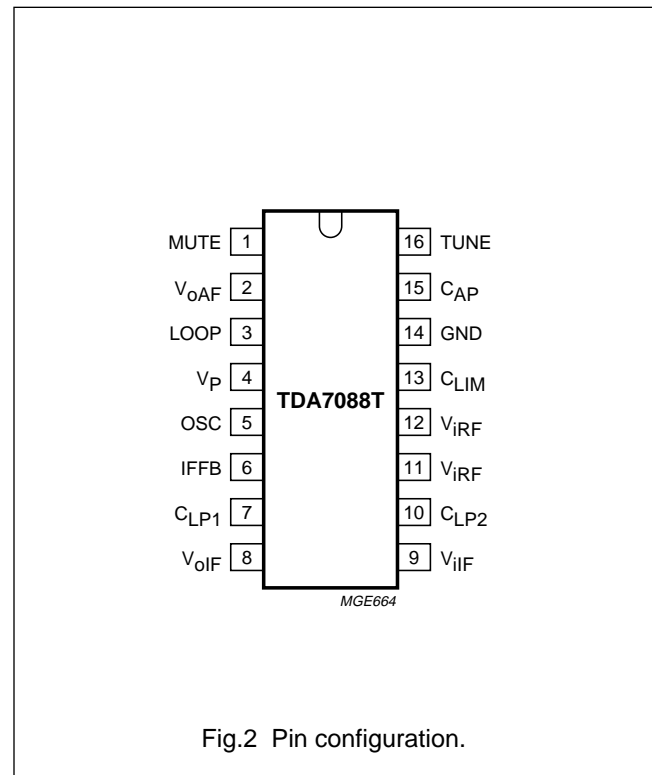

LIMITING VALUES

In accordance with the Absolute Maximum Rating System (IEC 134).

SYMBOL	PARAMETER	MIN.	MAX.	UNIT
V _P	supply voltage	0	5	V
T _{stg}	storage temperature	-55	+150	°C
T _{amb}	operating ambient temperature	-10	+70	°C
V _{es}	electrostatic handling; note 1	-	-	-

Note

- There is no special ESD protection circuit built-in; ESD data on request.

FM receiver circuit for battery supply

TDA7088T

DC CHARACTERISTICS

$V_P = 3\text{ V}$; $T_{\text{amb}} = 25\text{ °C}$; unless otherwise specified.

SYMBOL	PARAMETER	MIN.	TYP.	MAX.	UNIT
V_P	supply voltage (pin 4)	1.8	3	5	V
I_P	supply current (pin 4)	4.2	5.2	6.6	mA
V_1	DC voltage on pin 1	2.50	2.55	2.60	V
V_3	DC voltage on pin 3	2.64	2.69	2.74	V
$V_{6,7}$	DC voltage on pins 6 and 7	2.38	2.44	2.50	V
V_8	DC voltage on pin 8	1.60	1.67	1.74	V
$V_{9,10,13}$	DC voltage on pins 9, 10 and 13	2.42	2.47	2.52	V
$V_{11,12}$	DC voltage on pins 11 and 12	0.91	0.94	0.98	V
V_{15}	DC voltage on pin 15	2.06	2.12	2.18	V
I_2	AF output current on pin 2	45	60	80	μA
I_5	oscillator current on pin 5	275	375	500	μA

AC CHARACTERISTICS

$V_P = 3\text{ V}$; $T_{\text{amb}} = 25\text{ °C}$; $f_{\text{IRF}} = 96\text{ MHz}$ modulated with $f_{\text{mod}} = 1\text{ kHz}$ and $\pm 22.5\text{ kHz}$ deviation; $V_i = 400\text{ }\mu\text{V}$ (measured as EMF; $R_S = 75\text{ }\Omega$) and measurements taken in Fig.4; unless otherwise specified.

SYMBOL	PARAMETER	CONDITIONS	MIN.	TYP.	MAX.	UNIT
$V_{i(\text{rms})}$	RF sensitivity input voltage (RMS value)	$V_{\text{OAF}} = -3\text{ dB}$; $V_{\text{OAF}} = 0\text{ dB}$ at $V_i = 1\text{ mV}$; see Fig.3				
		mute off	–	3	6	μV
		mute on	3	6	12	μV
		$\frac{S+N}{N} = 26\text{ dB}$	–	5	10	μV
	signal handling	$\Delta f = \pm 75\text{ kHz}$; THD < 10%	100	200	–	mV
$\frac{S+N}{N}$	signal plus noise-to-noise ratio	see Fig.3	52	56	–	dB
THD	total harmonic distortion	$\Delta f = \pm 22.5\text{ kHz}$	–	1	1.4	%
		$\Delta f = \pm 75\text{ kHz}$	–	2.4	3.3	%
α_{AM}	AM suppression	FM: 1 kHz; $\pm 75\text{ kHz}$; AM: 1 kHz; $m = 0.8$	47	52	–	dB
RR_{1000}	ripple rejection	100 mV RMS ripple on V_P ; $f = 1\text{ kHz}$	7	10	–	dB
$V_{o(\text{rms})}$	audio output signal (RMS value)	$R_L = 22\text{ k}\Omega$	60	85	120	mV
Search tuning (with BB910 and $C_{16} = 0.1\text{ }\mu\text{F}$) see Fig.1						
V_{16}	minimum output voltage on pin 16	limiting point	–	$V_P - 1.85$	–	V
$\Delta V/\Delta t$	tuning steepness	voltage at pin 16	95	210	420	mV/s
$\Delta f_{\text{osc}}/\Delta t$	oscillator steepness		1.25	2.83	5.6	MHz/s
$\Delta I_{\text{AFC}}/\Delta V_3$	AFC steepness	voltage at pin 3	4.75	9.5	19	μS

FM receiver circuit for battery supply

TDA7088T

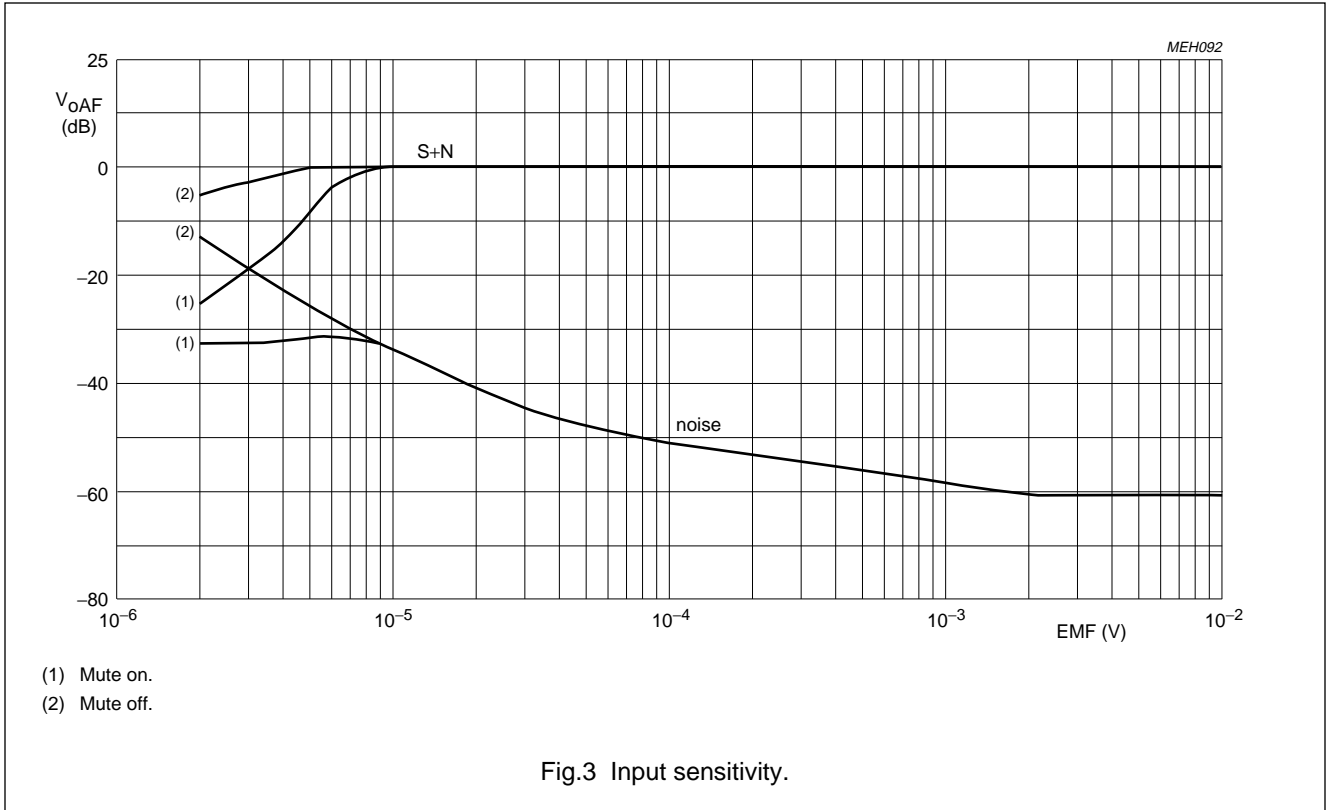

FM receiver circuit for battery supply

TDA7088T

TEST AND APPLICATION INFORMATION

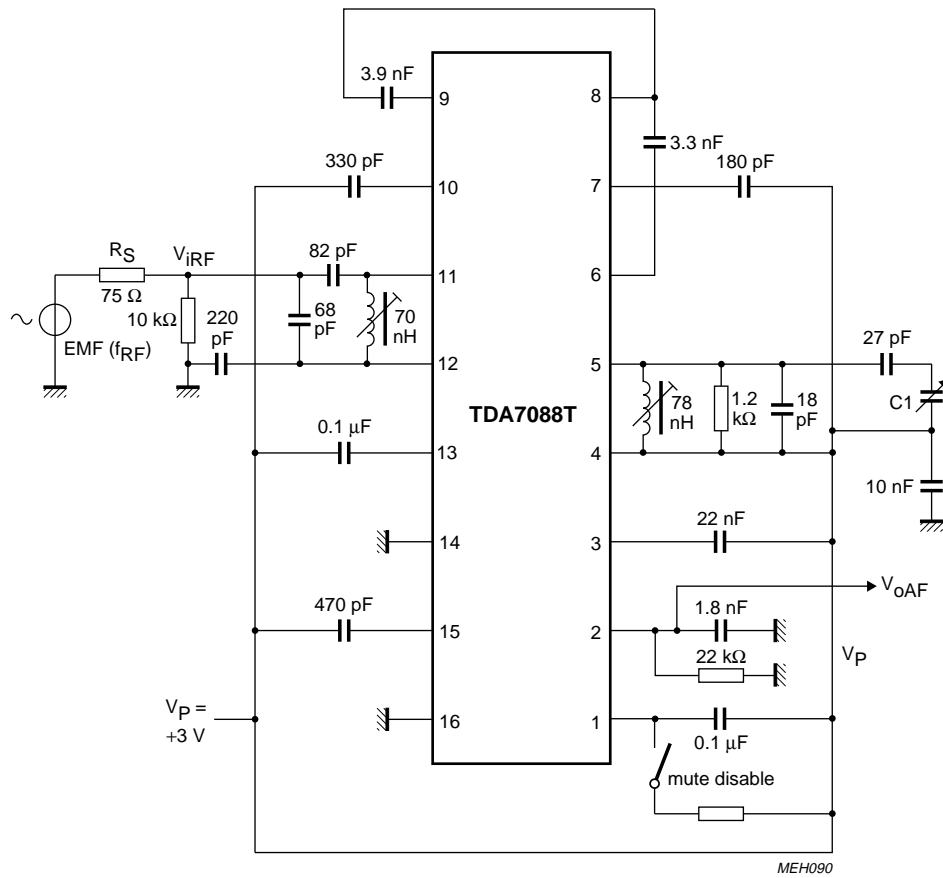

C1 = Toko 2A-15BT-R01.

Fig.4 Test circuit and application for mechanical tuning.

FM receiver circuit for battery supply

TDA7088T

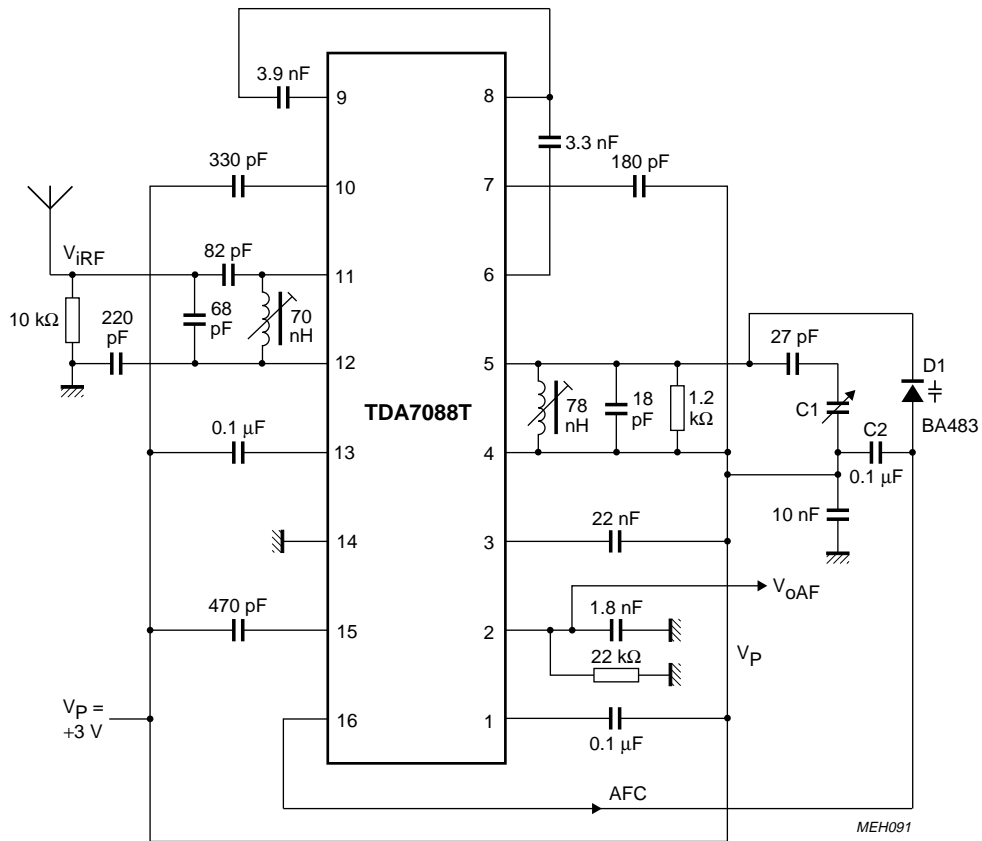

C1 = Toko 2A-15BT-R01.

Fig.5 Application circuit with AFC for mechanical tuning.

FM receiver circuit for battery supply

TDA7088T

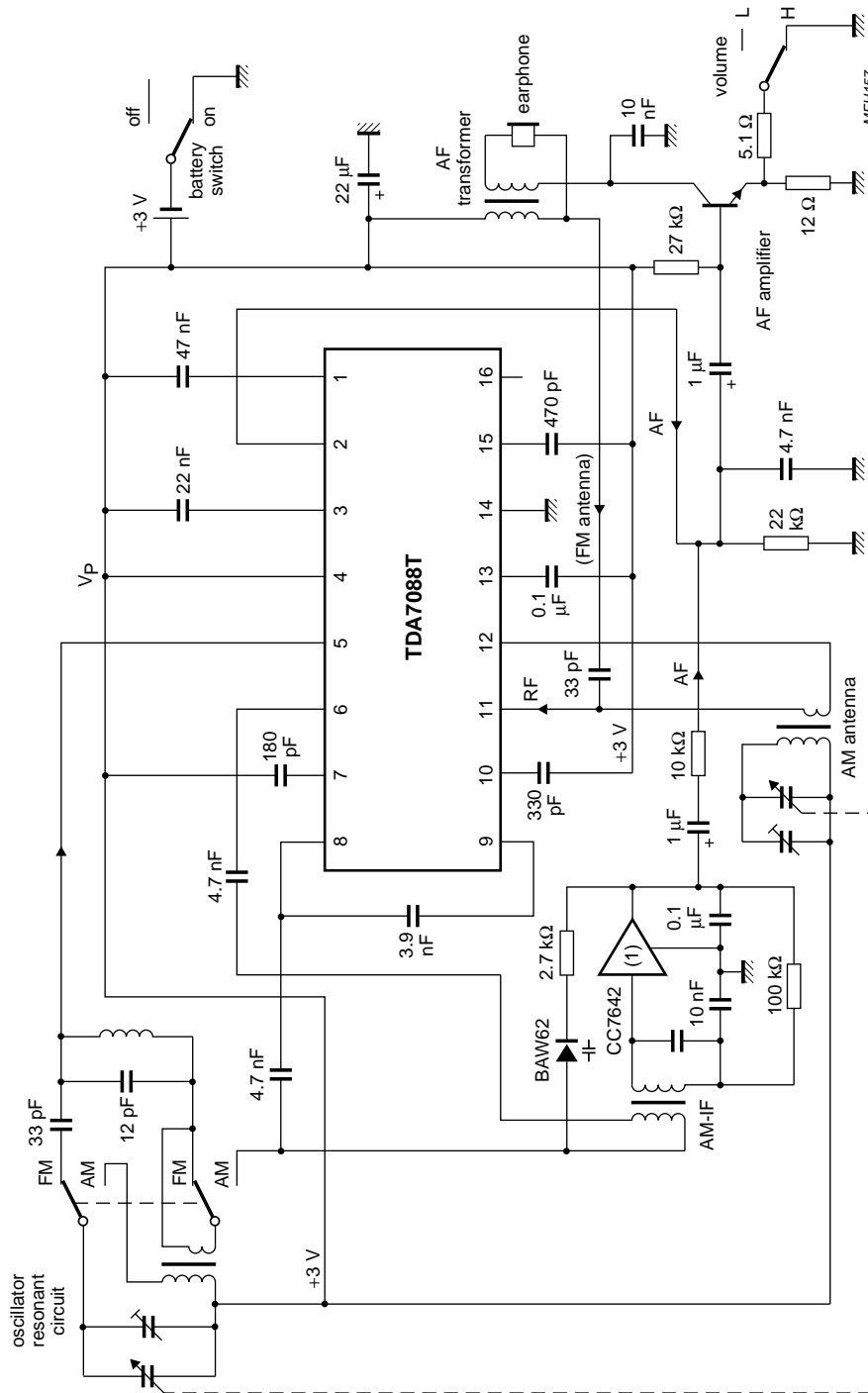

Fig.6 AM application circuit.

(1) CC7642: AM-IF amplifier/demodulator type number WU-xi 742 Fty.

FM receiver circuit for battery supply

TDA7088T

PACKAGE OUTLINE

SOT16: plastic small outline package; 16 leads; body width 3.9 mm

SOT109-1

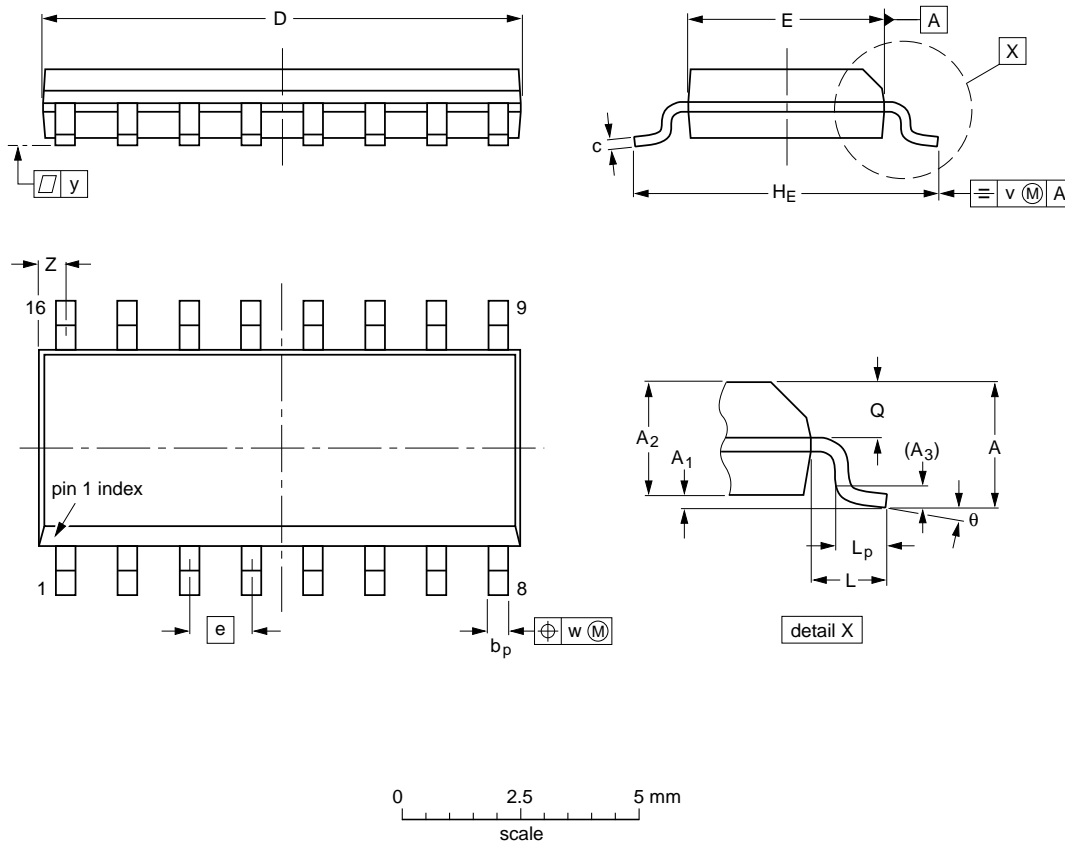

DIMENSIONS (inch dimensions are derived from the original mm dimensions)

UNIT	A max.	A ₁	A ₂	A ₃	b _p	c	D ⁽¹⁾	E ⁽¹⁾	e	H _E	L	L _p	Q	v	w	y	Z ⁽¹⁾	θ
mm	1.75	0.25 0.10	1.45 1.25	0.25	0.49 0.36	0.25 0.19	10.0 9.8	4.0 3.8	1.27	6.2 5.8	1.05	1.0 0.4	0.7 0.6	0.25	0.25	0.1	0.7 0.3	8° 0°
inches	0.069	0.0098 0.0039	0.057 0.049	0.01	0.019 0.014	0.0098 0.0075	0.39 0.38	0.16 0.15	0.050	0.24 0.23	0.041	0.039 0.016	0.028 0.020	0.01	0.01	0.004	0.028 0.012	

Note

1. Plastic or metal protrusions of 0.15 mm maximum per side are not included.

OUTLINE VERSION	REFERENCES				EUROPEAN PROJECTION	ISSUE DATE
	IEC	JEDEC	EIAJ			
SOT109-1	076E07S	MS-012AC				91-08-13 95-01-23

FM receiver circuit for battery supply

TDA7088T

SOLDERING

Introduction

There is no soldering method that is ideal for all IC packages. Wave soldering is often preferred when through-hole and surface mounted components are mixed on one printed-circuit board. However, wave soldering is not always suitable for surface mounted ICs, or for printed-circuits with high population densities. In these situations reflow soldering is often used.

This text gives a very brief insight to a complex technology. A more in-depth account of soldering ICs can be found in our *"IC Package Databook"* (order code 9398 652 90011).

Reflow soldering

Reflow soldering techniques are suitable for all SO packages.

Reflow soldering requires solder paste (a suspension of fine solder particles, flux and binding agent) to be applied to the printed-circuit board by screen printing, stencilling or pressure-syringe dispensing before package placement.

Several techniques exist for reflowing; for example, thermal conduction by heated belt. Dwell times vary between 50 and 300 seconds depending on heating method. Typical reflow temperatures range from 215 to 250 °C.

Preheating is necessary to dry the paste and evaporate the binding agent. Preheating duration: 45 minutes at 45 °C.

Wave soldering

Wave soldering techniques can be used for all SO packages if the following conditions are observed:

- A double-wave (a turbulent wave with high upward pressure followed by a smooth laminar wave) soldering technique should be used.
- The longitudinal axis of the package footprint must be parallel to the solder flow.
- The package footprint must incorporate solder thieves at the downstream end.

During placement and before soldering, the package must be fixed with a droplet of adhesive. The adhesive can be applied by screen printing, pin transfer or syringe dispensing. The package can be soldered after the adhesive is cured.

Maximum permissible solder temperature is 260 °C, and maximum duration of package immersion in solder is 10 seconds, if cooled to less than 150 °C within 6 seconds. Typical dwell time is 4 seconds at 250 °C.

A mildly-activated flux will eliminate the need for removal of corrosive residues in most applications.

Repairing soldered joints

Fix the component by first soldering two diagonally-opposite end leads. Use only a low voltage soldering iron (less than 24 V) applied to the flat part of the lead. Contact time must be limited to 10 seconds at up to 300 °C. When using a dedicated tool, all other leads can be soldered in one operation within 2 to 5 seconds between 270 and 320 °C.

FM receiver circuit for battery supply

TDA7088T

DEFINITIONS

Data sheet status	
Objective specification	This data sheet contains target or goal specifications for product development.
Preliminary specification	This data sheet contains preliminary data; supplementary data may be published later.
Product specification	This data sheet contains final product specifications.
Limiting values	
Limiting values given are in accordance with the Absolute Maximum Rating System (IEC 134). Stress above one or more of the limiting values may cause permanent damage to the device. These are stress ratings only and operation of the device at these or at any other conditions above those given in the Characteristics sections of the specification is not implied. Exposure to limiting values for extended periods may affect device reliability.	
Application information	
Where application information is given, it is advisory and does not form part of the specification.	

LIFE SUPPORT APPLICATIONS

These products are not designed for use in life support appliances, devices, or systems where malfunction of these products can reasonably be expected to result in personal injury. Philips customers using or selling these products for use in such applications do so at their own risk and agree to fully indemnify Philips for any damages resulting from such improper use or sale.

FM receiver circuit for battery supply

TDA7088T

NOTES

FM receiver circuit for battery supply

TDA7088T

NOTES

FM receiver circuit for battery supply

TDA7088T

NOTES

Philips Semiconductors – a worldwide company

Argentina: see South America

Australia: 34 Waterloo Road, NORTH RYDE, NSW 2113,
Tel. (02) 805 4455, Fax. (02) 805 4466

Austria: Computerstr. 6, A-1101 WIEN, P.O. Box 213,
Tel. (01) 60 101-1256, Fax. (01) 60 101-1250

Belarus: Hotel Minsk Business Center, Bld. 3, r. 1211,
Volodarski Str. 6, 220050 MINSK,
Tel. (172) 200 733, Fax. (172) 200 773

Belgium: see The Netherlands

Brazil: see South America

Bulgaria: Philips Bulgaria Ltd., Energoproject, 15th floor,
51 James Bourchier Blvd., 1407 SOFIA,
Tel. (359) 2 689 211, Fax. (359) 2 689 102

Canada: PHILIPS SEMICONDUCTORS/COMPONENTS:
Tel. (800) 234-7381, Fax. (708) 296-8556

Chile: see South America

China/Hong Kong: 501 Hong Kong Industrial Technology Centre,
72 Tat Chee Avenue, Kowloon Tong, HONG KONG,
Tel. (852) 2319 7888, Fax. (852) 2319 7700

Colombia: see South America

Czech Republic: see Austria

Denmark: Prags Boulevard 80, PB 1919, DK-2300
COPENHAGEN S, Tel. (032) 88 2636, Fax. (031) 57 1949

Finland: Sinikalliontie 3, FIN-02630 ESPOO,
Tel. (358) 0-615 800, Fax. (358) 0-61580 920

France: 4 Rue du Port-aux-Vins, BP317,
92156 SURESNES Cedex,
Tel. (01) 4099 6161, Fax. (01) 4099 6427

Germany: P.O. Box 10 51 40, 20035 HAMBURG,
Tel. (040) 23 53 60, Fax. (040) 23 53 63 00

Greece: No. 15, 25th March Street, GR 17778 TAVROS,
Tel. (01) 4894 339/4894 911, Fax. (01) 4814 240

Hungary: see Austria

India: Philips INDIA Ltd, Shivsagar Estate, A Block,
Dr. Annie Besant Rd. Worli, BOMBAY 400 018
Tel. (022) 4938 541, Fax. (022) 4938 722

Indonesia: see Singapore

Ireland: Newstead, Clonskeagh, DUBLIN 14,
Tel. (01) 7640 000, Fax. (01) 7640 200

Israel: RAPAC Electronics, 7 Kehilat Saloniki St, TEL AVIV 61180,
Tel. (03) 645 04 44, Fax. (03) 648 10 07

Italy: PHILIPS SEMICONDUCTORS,
Piazza IV Novembre 3, 20124 MILANO,
Tel. (0039) 2 6752 2531, Fax. (0039) 2 6752 2557

Japan: Philips Bldg 13-37, Kohnan 2-chome, Minato-ku,
TOKYO 108, Tel. (03) 3740 5130, Fax. (03) 3740 5077

Korea: Philips House, 260-199 Itaewon-dong,
Yongsan-ku, SEOUL, Tel. (02) 709-1412, Fax. (02) 709-1415

Malaysia: No. 76 Jalan Universiti, 46200 PETALING JAYA,
SELANGOR, Tel. (03) 750 5214, Fax. (03) 757 4880

Mexico: 5900 Gateway East, Suite 200, EL PASO,
TEXAS 79905, Tel. 9-5(800) 234-7831, Fax. (708) 296-8556

Middle East: see Italy

Netherlands: Postbus 90050, 5600 PB EINDHOVEN, Bldg. VB,
Tel. (040) 2783749, Fax. (040) 2788399

New Zealand: 2 Wagener Place, C.P.O. Box 1041, AUCKLAND,
Tel. (09) 849-4160, Fax. (09) 849-7811

Norway: Box 1, Manglerud 0612, OSLO,
Tel. (022) 74 8000, Fax. (022) 74 8341

Philippines: PHILIPS SEMICONDUCTORS PHILIPPINES Inc.,
106 Valero St. Saicedo Village, P.O. Box 2108 MCC,
MAKATI, Metro MANILA,
Tel. (63) 2 816 6380, Fax. (63) 2 817 3474

Poland: Ul. Lukiska 10, PL 04-123 WARSZAWA,
Tel. (022) 612 2831, Fax. (022) 612 2327

Portugal: see Spain

Romania: see Italy

Singapore: Lorong 1, Toa Payoh, SINGAPORE 1231,
Tel. (65) 350 2000, Fax. (65) 251 6500

Slovakia: see Austria

Slovenia: see Italy

South Africa: S.A. PHILIPS Pty Ltd.,
195-215 Main Road Martindale, 2092 JOHANNESBURG,
P.O. Box 7430 Johannesburg 2000,
Tel. (011) 470-5911, Fax. (011) 470-5494

South America: Rua do Rocio 220 - 5th floor, Suite 51,
CEP: 04552-903-SÃO PAULO-SP, Brazil,
P.O. Box 7383 (01064-970),
Tel. (011) 821-2333, Fax. (011) 829-1849

Spain: Balmes 22, 08007 BARCELONA,
Tel. (03) 301 6312, Fax. (03) 301 4107

Sweden: Kottbygatan 7, Akalla. S-16485 STOCKHOLM,
Tel. (0) 8-632 2000, Fax. (0) 8-632 2745

Switzerland: Allmendstrasse 140, CH-8027 ZÜRICH,
Tel. (01) 488 2211, Fax. (01) 481 77 30

Taiwan: PHILIPS TAIWAN Ltd., 23-30F, 66,
Chung Hsiao West Road, Sec. 1, P.O. Box 22978,
TAIPEI 100, Tel. (886) 2 382 4443, Fax. (886) 2 382 4444

Thailand: PHILIPS ELECTRONICS (THAILAND) Ltd.,
209/2 Sanpavuth-Bangna Road Prakanong, BANGKOK 10260,
Tel. (66) 2 745-4090, Fax. (66) 2 398-0793

Turkey: Talatpasa Cad. No. 5, 80640 GÜLTEPE/ISTANBUL,
Tel. (0212) 279 2770, Fax. (0212) 282 6707

Ukraine: PHILIPS UKRAINE,
2A Akademika Koroleva str., Office 165, 252148 KIEV,
Tel. 380-44-4760297, Fax. 380-44-4766991

United Kingdom: Philips Semiconductors LTD.,
276 Bath Road, Hayes, MIDDLESEX UB3 5BX,
Tel. (0181) 730-5000, Fax. (0181) 754-8421

United States: 811 East Arques Avenue, SUNNYVALE,
CA 94088-3409, Tel. (800) 234-7381, Fax. (708) 296-8556

Uruguay: see South America

Vietnam: see Singapore

Yugoslavia: PHILIPS, Trg N. Pasicca 5/v, 11000 BEOGRAD,
Tel. (381) 11 825 344, Fax. (359) 211 635 777

Internet: <http://www.semiconductors.philips.com/ps/>

For all other countries apply to: Philips Semiconductors,
Marketing & Sales Communications, Building BE-p,
P.O. Box 218, 5600 MD EINDHOVEN, The Netherlands,
Fax. +31-40-2724825

SCDS48 © Philips Electronics N.V. 1996

All rights are reserved. Reproduction in whole or in part is prohibited without the prior written consent of the copyright owner.

The information presented in this document does not form part of any quotation or contract, is believed to be accurate and reliable and may be changed without notice. No liability will be accepted by the publisher for any consequence of its use. Publication thereof does not convey nor imply any license under patent- or other industrial or intellectual property rights.

Printed in The Netherlands

517021/1200/02/pp16
Document order number:

Date of release: 1996 May 14
9397 750 00843