

TV VERTICAL DEFLECTION OUTPUT CIRCUIT

- POWER AMPLIFIER
- FLYBACK GENERATOR
- THERMAL PROTECTION

DESCRIPTION

The TDA8172 is a monolithic integrated circuit in HEPTAWATT™ package. It is a high efficiency power booster for direct driving of vertical windings of TV yokes. It is intended for use in Color and B & W television as well as in monitors and displays.

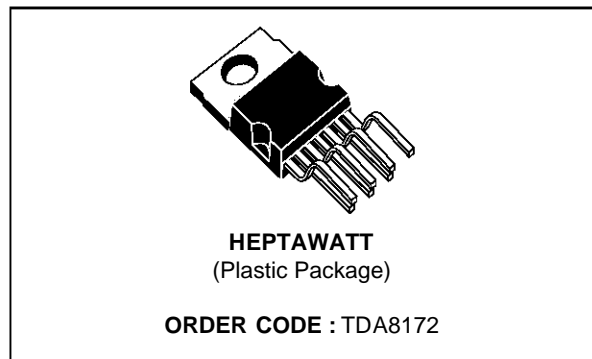

PIN CONNECTIONS (top view)

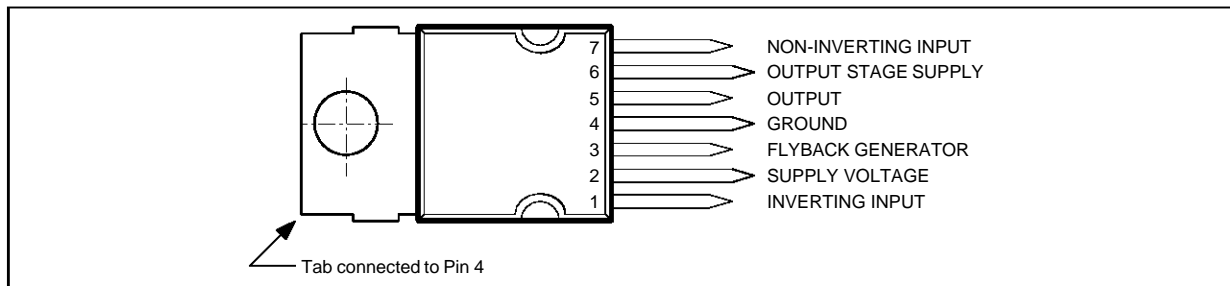

BLOCK DIAGRAM

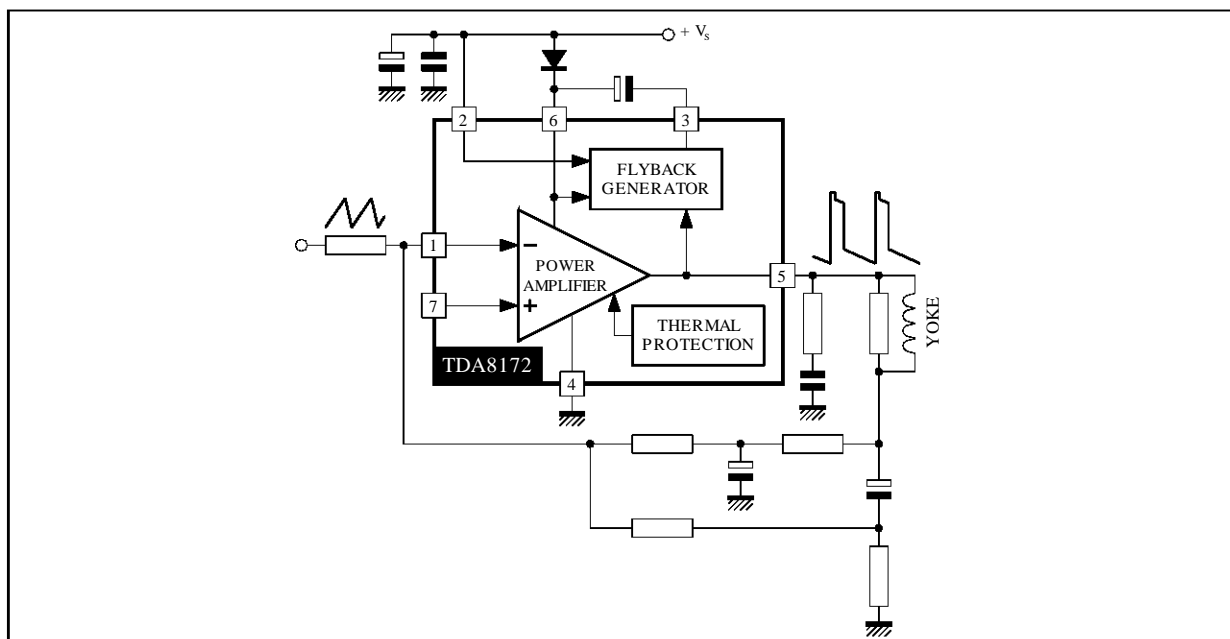

ABSOLUTE MAXIMUM RATINGS

Symbol	Parameter	Value	Unit
V _S	Supply Voltage (pin 2)	35	V
V ₅ , V ₆	Flyback Peak Voltage	60	V
V ₃	Voltage at Pin 3	+ V _S	
V ₁ , V ₇	Amplifier Input Voltage	+ V _S - 0.5	V
I _o	Output Peak Current (non repetitive, t = 2 ms)	2.5	A
I _o	Output Peak Current at f = 50 or 60 Hz, t ≤ 10 μs	3	A
I _o	Output Peak Current at f = 50 or 60 Hz, t > 10 μs	2	A
I ₃	Pin 3 DC Current at V ₅ < V ₂	100	mA
I ₃	Pin 3 Peak to Peak Flyback Current at f = 50 or 60 Hz, t _{fly} ≤ 1.5 ms	3	A
P _{tot}	Total Power Dissipation at T _{case} = 90 °C	20	W
T _{stg} , T _j	Storage and Junction Temperature	- 40, +150	°C

8172-01.TBL

THERMAL DATA

Symbol	Parameter	Value	Unit
R _{th(j-c)}	Thermal Resistance Junction-case	Max. 3	°C/W

8172-02.TBL

ELECTRICAL CHARACTERISTICS

(refer to the test circuits, V_S = 35V, T_{amb} = 25°C unless otherwise specified)

Symbol	Parameter	Test Conditions	Min.	Typ.	Max.	Unit	Fig.
I ₂	Pin 2 Quiescent Current	I ₃ = 0, I ₅ = 0		8	16	mA	1a
I ₆	Pin 6 Quiescent Current	I ₃ = 0, I ₅ = 0		16	36	mA	1a
I ₁	Amplifier Input Bias Current	V ₁ = 1 V, V ₇ = 2 V		- 0.1	- 1	μA	1a
		V ₁ = 2 V, V ₇ = 1 V		- 0.1	- 1	μA	1a
V _{3L}	Pin 3 Saturation Voltage to GND	I ₃ = 20 mA		1	1.5	V	1c
V ₅	Quiescent Output Voltage	V _S = 35V, R _a = 39 kΩ		18		V	1d
V _{5L}	Output Saturation Voltage to GND	I ₅ = 1.2 A		1	1.4	V	1c
		I ₅ = 0.7 A		0.7	1	V	1c
V _{5H}	Output Saturation Voltage to Supply	- I ₅ = 1.2 A		1.6	2.2	V	1b
		- I ₅ = 0.7 A		1.3	1.8	V	1b
T _j	Junction Temperature for Thermal Shut Down			140		°C	

8172-03.TBL

Figure 1 : DC Test Circuits.

Figure 1 a : Measurement of I_1 ; I_2 ; I_6

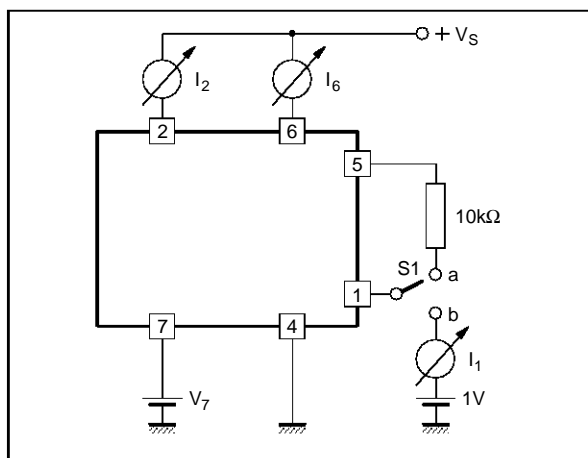

8172-03.EPS

S₁ : (a) I_2 and I_6 ; (b) I_1

Figure 1 b : Measurement of V_{5H}

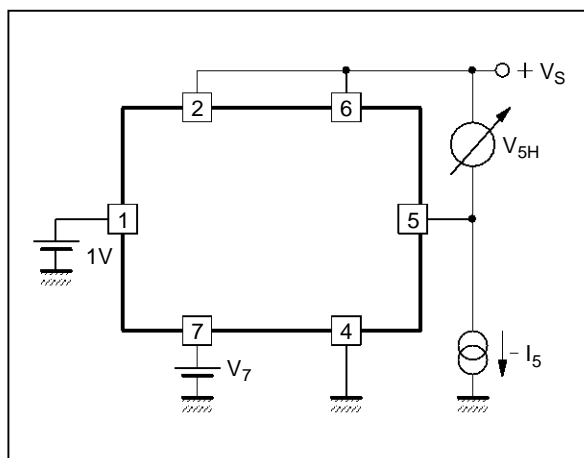

8172-04.EPS

Figure 1 c : Measurement of V_{3L} ; V_{5L}

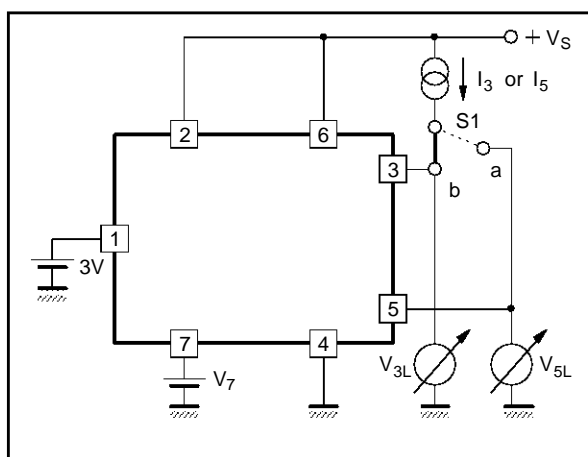

8172-05.EPS

S₁ : (a) V_{3L} ; (b) V_{5L}

Figure 1 d : Measurement of V_5

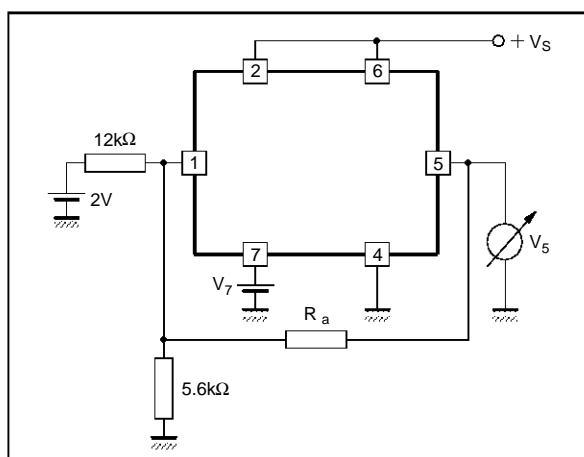

8172-06.EPS

Figure 2 : AC Test Circuit

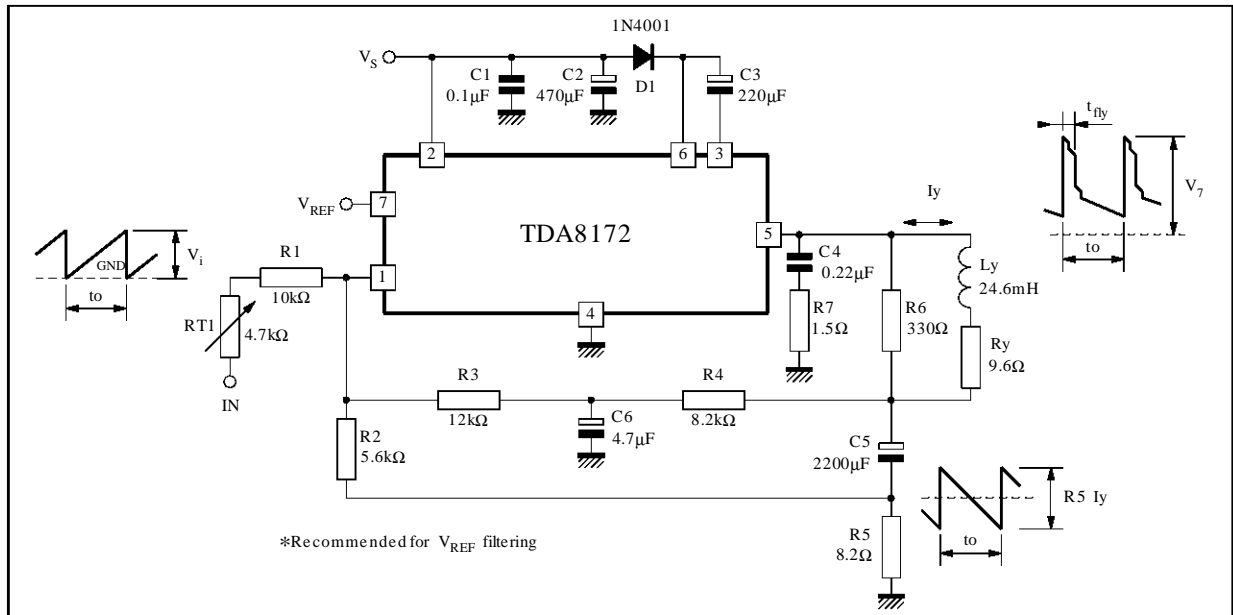

8172-07.EPS

MOUNTING INSTRUCTIONS

The power dissipated in the circuit must be removed by adding an external heatsink. Thanks to the HEPTAWATT™ package attaching the heatsink is very simple, a screw or a compression spring (clip) being sufficient.

Between the heatsink and the package it is better to insert a layer of silicon grease, to optimize the thermal contact ; no electrical isolation is needed between the two surfaces, since the tab is connected to Pin 4 which is ground.

Figure 3 : Mounting Examples

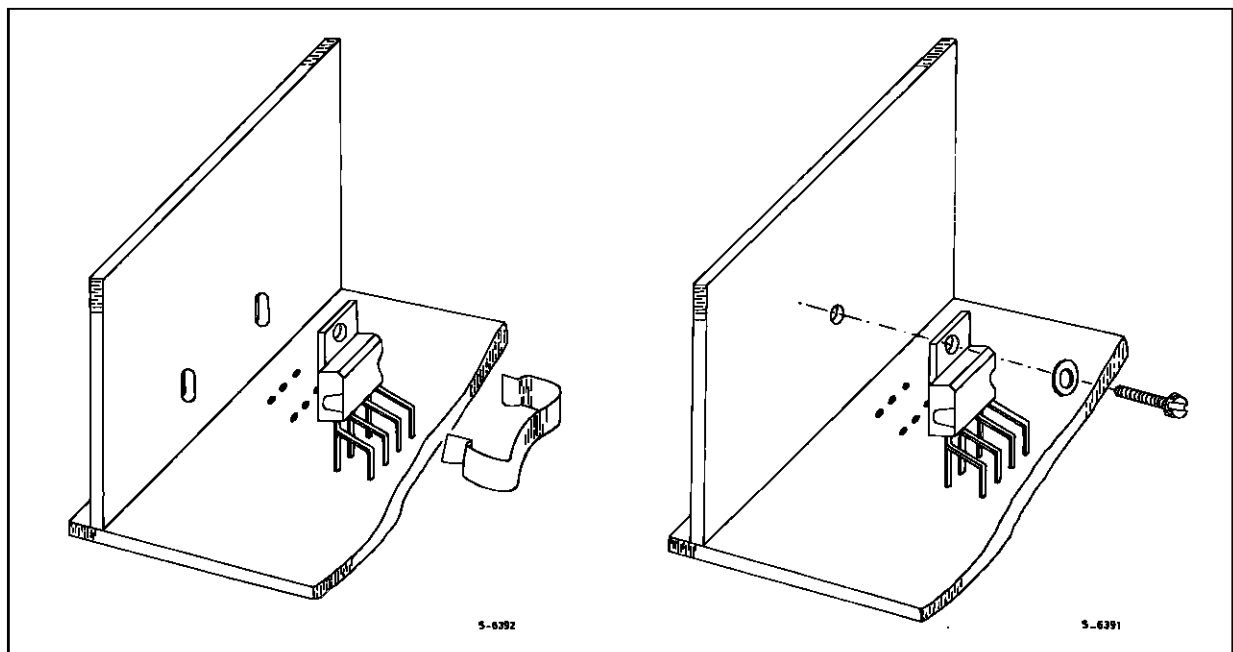

8172-08.EPS - 8172-09.EPS

PACKAGE MECHANICAL DATA : 9 PINS - PLASTIC HEPTAWATT

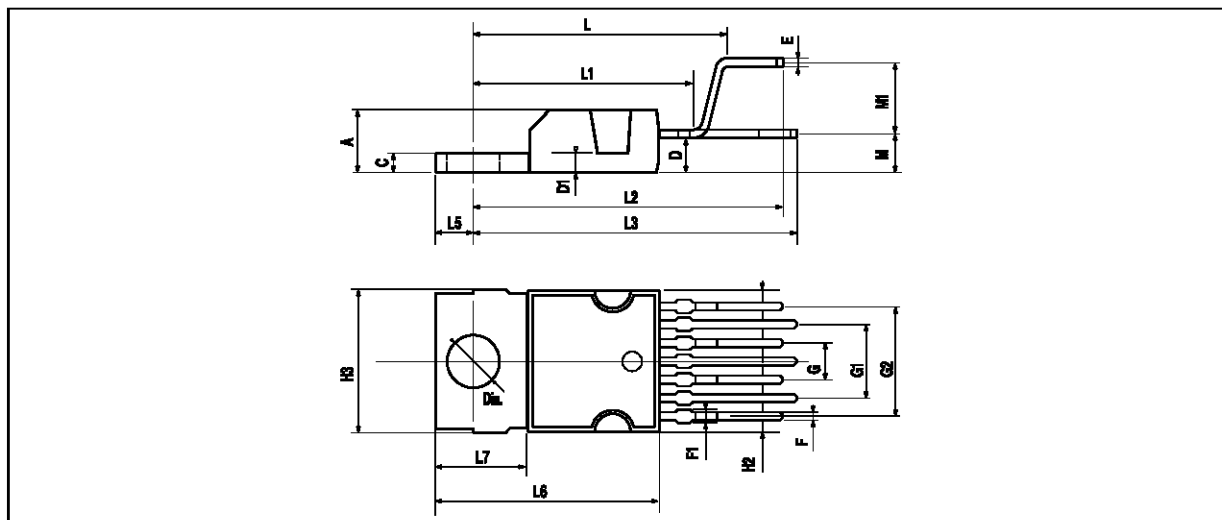

PM-HEPTV.EPS

Dimensions	Millimeters			Inches		
	Min.	Typ.	Max.	Min.	Typ.	Max.
A			4.8			0.189
C			1.37			0.054
D	2.4		2.8	0.094		0.110
D1	1.2		1.35	0.047		0.053
E	0.35		0.55	0.014		0.022
F	0.6		0.8	0.024		0.031
F1			0.9			0.035
G	2.41	2.54	2.67	0.095	0.100	0.105
G1	4.91	5.08	5.21	0.193	0.200	0.205
G2	7.49	7.62	7.8	0.295	0.300	0.307
H2			10.4			0.409
H3	10.05		10.4	0.396		0.409
L		16.97			0.668	
L1		14.92			0.587	
L2		21.54			0.848	
L3		22.62			0.891	
L5	2.6		3	0.102		0.118
L6	15.1		15.8	0.594		0.622
L7	6		6.6	0.236		0.260
M		2.8			0.110	
M1		5.08			0.200	
Dia.	3.65		3.85	0.144		0.152

HEPTV.TBL

Information furnished is believed to be accurate and reliable. However, SGS-THOMSON Microelectronics assumes no responsibility for the consequences of use of such information nor for any infringement of patents or other rights of third parties which may result from its use. No licence is granted by implication or otherwise under any patent or patent rights of SGS-THOMSON Microelectronics. Specifications mentioned in this publication are subject to change without notice. This publication supersedes and replaces all information previously supplied. SGS-THOMSON Microelectronics products are not authorized for use as critical components in life support devices or systems without express written approval of SGS-THOMSON Microelectronics.

© 1996 SGS-THOMSON Microelectronics - All Rights Reserved

Purchase of i^2C Components of SGS-THOMSON Microelectronics, conveys a license under the Philips i^2C Patent. Rights to use these components in a i^2C system, is granted provided that the system conforms to the i^2C Standard Specifications as defined by Philips.

SGS-THOMSON Microelectronics GROUP OF COMPANIES

Australia - Brazil - Canada - China - France - Germany - Hong Kong - Italy - Japan - Korea - Malaysia - Malta - Morocco
The Netherlands - Singapore - Spain - Sweden - Switzerland - Taiwan - Thailand - United Kingdom - U.S.A.