

## I<sup>2</sup>C-bus controlled PAL/NTSC TV processor

### TDA8366

#### FEATURES

- Multistandard vision IF circuit (positive and negative modulation)
- Video identification circuit in the IF circuit which is independent of the synchronization for stable On Screen Display (OSD) under 'no-signal' conditions
- Source selection with 2 Colour Video Blanking Synchronization (CVBS) inputs and a Y/C (or extra CVBS) input
- Output signals of the video switch circuit for the teletext decoder and a Picture-In-Picture (PIP) processor
- Integrated chrominance trap and bandpass filters (automatically calibrated)
- Integrated luminance delay line
- Asymmetrical peaking in the luminance channel with a (defeatable) noise coring function
- PAL/NTSC colour decoder with automatic search system
- Easy interfacing with the TDA8395 (SECAM decoder) for multistandard applications
- RGB control circuit with black-current stabilization and white point adjustment; to obtain a good grey scale tracking the black-current ratio of the 3 guns depends on the white point adjustment
- Linear RGB inputs and fast blanking
- Horizontal synchronization with two control loops and alignment-free horizontal oscillator
- Vertical count-down circuit
- Geometry correction by means of modulation of the vertical and EW drive
- I<sup>2</sup>C-bus control of various functions
- Low dissipation (850 mW)
- Small amount of peripheral components compared with competition ICs
- Only one adjustment (vision IF demodulator)
- Y, U and V inputs and outputs.



#### GENERAL DESCRIPTION

The TDA8366 is an I<sup>2</sup>C-bus controlled PAL/NTSC TV processor. The circuit has been designed for use with the baseband chrominance delay line TDA4665 and for DC-coupled vertical and East-West (EW) output stages.

The device can process both CVBS and Y/C input signals and has a linear RGB-input with fast blanking.

The peaking circuit generates asymmetrical overshoots (the amplitude of the 'black' overshoots is approximately 2 times higher as the one of the 'white' overshoots) and contains a (defeatable) coring function.

The RGB control circuit contains a black-current stabilizer circuit with internal clamp capacitors. The white point of the picture tube is adjusted via the I<sup>2</sup>C-bus.

The deflection control circuit provides a drive pulse for the horizontal output stage, a differential sawtooth current for the vertical output stage and an East-West drive current for the East-West output stage. These signals can be manipulated for geometry correction of the picture.

The supply voltage for the IC is 8 V. The IC is available in an SDIP package with 52 pins and in a QFP package with 64 pins (see Chapter "Ordering information").

The pin numbers indicated in this document are referenced to the SDIP52; SOT247-1 package; unless otherwise indicated.

## I<sup>2</sup>C-bus controlled PAL/NTSC TV processor

TDA8366

### ORDERING INFORMATION

TYPE NUMBER	PACKAGE		
	NAME	DESCRIPTION	VERSION
TDA8366	SDIP52	plastic shrink dual in-line package; 52 leads (600 mil)	SOT247-1
TDA8366H	QFP64 <sup>(1)</sup>	plastic quad flat package; 64 leads (lead length 1.95 mm); body 14 × 20 × 2.8 mm	SOT319-2

### Note

- When using IR reflow soldering it is recommended that the Drypack instructions in the "Quality Reference Handbook" (order number 9398 510 63011) are followed.

### QUICK REFERENCE DATA

SYMBOL	PARAMETER	MIN.	TYP.	MAX.	UNIT
<b>Supply</b>					
V <sub>P</sub>	supply voltage	–	8.0	–	V
I <sub>P</sub>	supply current	–	100	–	mA
<b>Input voltages</b>					
V <sub>46,47(rms)</sub>	video IF amplifier sensitivity (RMS value)	–	70	–	μV
V <sub>15(p-p)</sub>	external CVBS input (peak-to-peak value)	–	1.0	–	V
V <sub>9(p-p)</sub>	S-VHS luminance input voltage (peak-to-peak value)	–	1.0	–	V
V <sub>8(p-p)</sub>	S-VHS chroma input voltage (burst amplitude) (peak-to-peak value)	–	0.3	–	V
V <sub>21,22,23(p-p)</sub>	RGB inputs (peak-to-peak value)	–	0.7	–	V
<b>Output signals</b>					
V <sub>0(p-p)</sub>	demodulated CVBS output (peak-to-peak value)	–	2.5	–	V
I <sub>52</sub>	tuner AGC output current range	0	–	5	mA
V <sub>36(p-p)</sub>	TXT output voltage (peak-to-peak value)	–	1.0	–	V
V <sub>13(p-p)</sub>	PIP output voltage (peak-to-peak value)	–	1.0	–	V
V <sub>28(p-p)</sub>	–(R–Y) output voltage (peak-to-peak value)	–	525	–	mV
V <sub>27(p-p)</sub>	–(B–Y) output voltage (peak-to-peak value)	–	675	–	mV
V <sub>26</sub>	Y output voltage	–	450	–	mV
V <sub>19,18,17(p-p)</sub>	RGB output signal amplitudes (peak-to-peak value)	–	2.0	–	V
I <sub>38</sub>	horizontal output current	10	–	–	mA
I <sub>44,45</sub>	vertical output current	1	–	–	mA
I <sub>43</sub>	EW drive output current	0.5	–	–	mA

# I<sup>2</sup>C-bus controlled PAL/NTSC TV processor

TDA8366

## BLOCK DIAGRAM

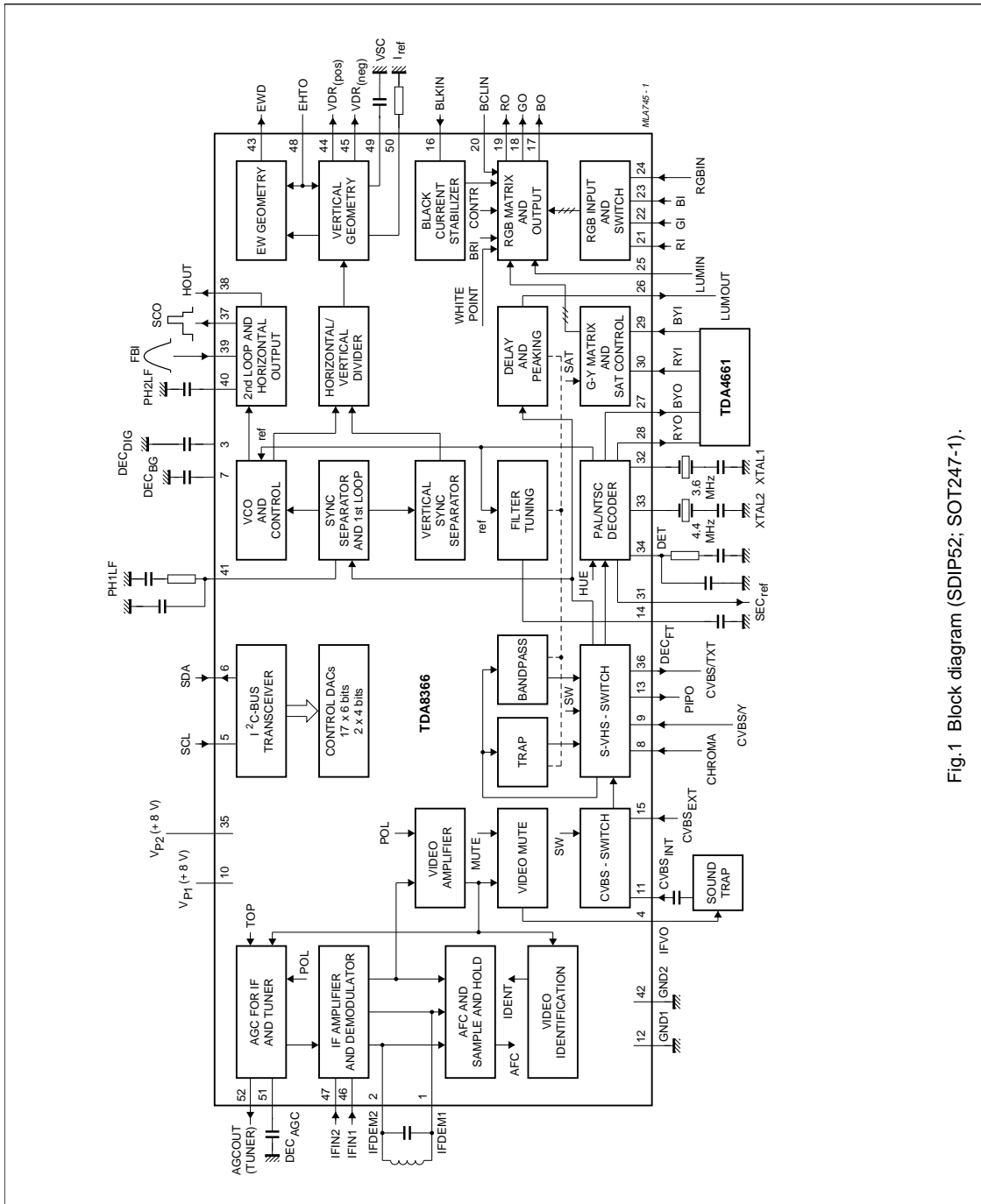

Fig. 1 Block diagram (SDIP52; SOT247-1).

## I<sup>2</sup>C-bus controlled PAL/NTSC TV processor

TDA8366

### PINNING

SYMBOL	PIN		DESCRIPTION
	SDIP52	QFP64	
IFDEM1	1	11	IF demodulator tuned circuit 1
IFDEM2	2	12	IF demodulator tuned circuit 2
DEC <sub>DIG</sub>	3	13	decoupling digital supply
IFVO	4	14	IF video output
SCL	5	16	serial clock input
SDA	6	17	serial data input/output
DEC <sub>BG</sub>	7	18	bandgap decoupling
CHROMA	8	20	chrominance input (S-VHS)
CVBS/Y	9	21	external CVBS/Y input
V <sub>P1</sub>	10	22	main supply voltage 1 (+8 V)
CVBS <sub>INT</sub>	11	29	internal CVBS input
GND1	12	25	ground 1
PIPO	13	27	picture-in-picture output
DEC <sub>FT</sub>	14	28	decoupling filter tuning
CVBS <sub>EXT</sub>	15	24	external CVBS input
BLKIN	16	30	black-current input
BO	17	31	blue output
GO	18	32	green output
RO	19	33	red output
BCLIN	20	35	beam current limiter input
RI	21	37	red input for insertion
GI	22	38	green input for insertion
BI	23	39	blue input for insertion
RGBIN	24	40	RGB insertion input
LUMIN	25	42	luminance input
LUMOUT	26	43	luminance output
BYO	27	44	(B-Y) signal output
RYO	28	45	(R-Y) signal output
BYI	29	46	(B-Y) signal input
RYI	30	47	(R-Y) signal input
SEC <sub>ref</sub>	31	48	SECAM reference output
XTAL1	32	49	3.58 MHz crystal connection
XTAL2	33	50	4.43/3.58 MHz crystal connection
DET	34	52	loop filter phase detector
V <sub>P2</sub>	35	54	horizontal oscillator supply voltage (+8 V)
CVBS/TXT	36	55	CVBS/TXT output
SCO	37	56	sandcastle output
HOUT	38	57	horizontal output

## I<sup>2</sup>C-bus controlled PAL/NTSC TV processor

TDA8366

SYMBOL	PIN		DESCRIPTION
	SDIP52	QFP64	
FBI	39	58	flyback input
PH2LF	40	59	phase-2 filter
PH1LF	41	60	phase-1 filter
GND2	42	26	ground 2
EWD	43	63	east-west drive output
VDR <sub>(pos)</sub>	44	64	vertical drive 1 positive output
VDR <sub>(neg)</sub>	45	1	vertical drive 2 negative output
IFIN1	46	2	IF input 1
IFIN2	47	3	IF input 2
EHTO	48	4	EHT/overvoltage protection input
VSC	49	5	vertical sawtooth capacitor
I <sub>ref</sub>	50	6	reference current input
DEC <sub>AGC</sub>	51	7	AGC decoupling capacitor
AGCOUT	52	8	tuner AGC output
n.c.	–	9	not connected
n.c.	–	10	not connected
n.c.	–	15	not connected
n.c.	–	19	not connected
n.c.	–	34	not connected
n.c.	–	36	not connected
n.c.	–	41	not connected
n.c.	–	51	not connected
n.c.	–	53	not connected
V <sub>P3</sub>	–	23	supply voltage 3 (+8 V)
GND3	–	61	ground 3
GND4	–	62	ground 4

The pin numbers mentioned in the rest of this document are referenced to the SDIP52 (SOT247-1) package.

I<sup>2</sup>C-bus controlled PAL/NTSC TV processor

TDA8366

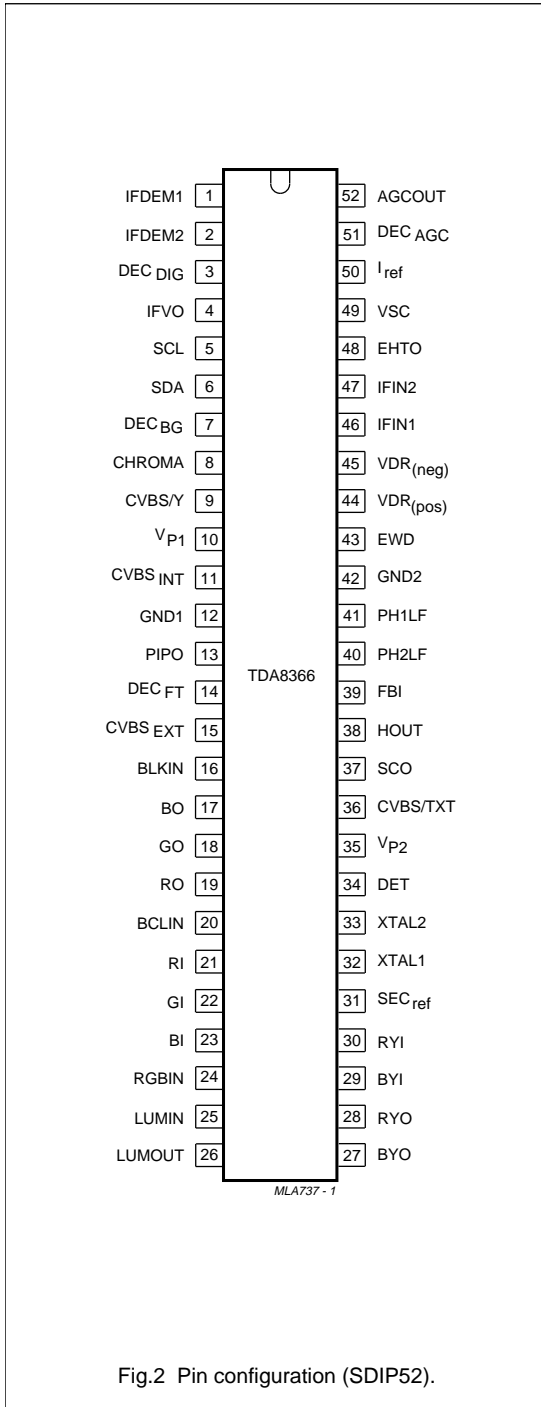

I<sup>2</sup>C-bus controlled PAL/NTSC TV processor

TDA8366

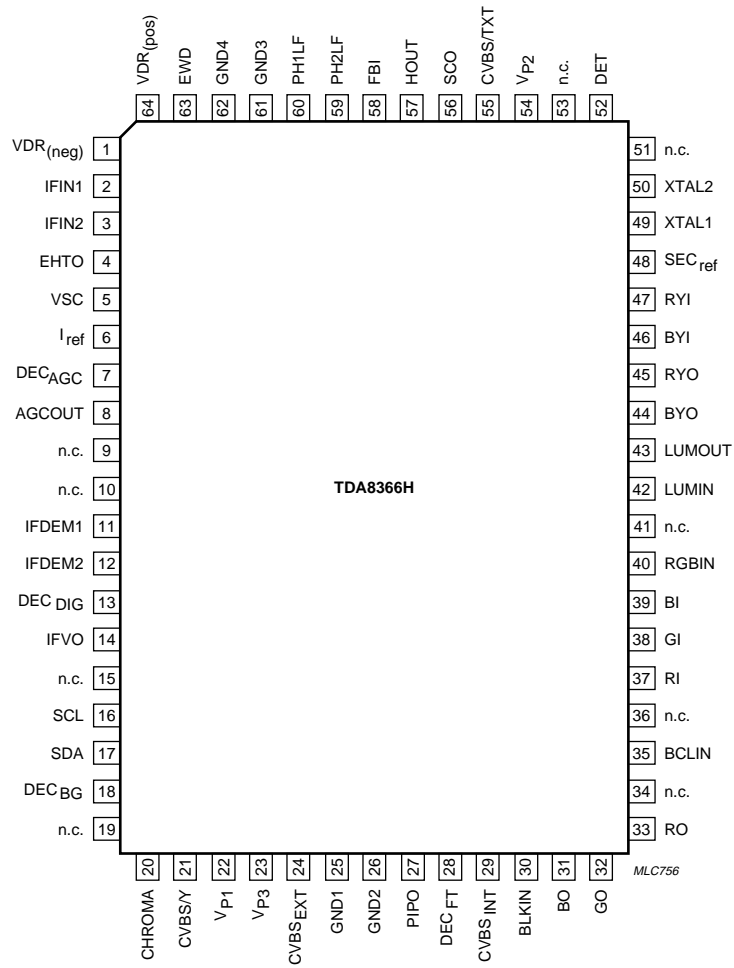

Fig.3 Pin configuration (QFP64).

---

## I<sup>2</sup>C-bus controlled PAL/NTSC TV processor

---

TDA8366

### FUNCTIONAL DESCRIPTION

#### Vision IF amplifier

The IF-amplifier contains 3 AC-coupled control stages with a total gain control range which is in excess of 66 dB. The sensitivity of the circuit is comparable with that of modern IF-ICs. The reference carrier for the video demodulator is obtained by means of passive regeneration of the picture carrier. The external reference tuned circuit is the only remaining adjustment of the IC.

The polarity of the demodulator can be switched via the I<sup>2</sup>C-bus in such a way that the circuit is suitable for both positive and negative modulated signals.

The AFC-circuit is driven with the same reference signal as the video demodulator. To avoid that the video content disturbs the AFC operation a sample-and-hold circuit is applied for signals with negative modulation. The capacitor for this function is internal. The AFC information is supplied to the tuning system via the I<sup>2</sup>C-bus.

The AGC-detector operates on top-sync or top white-level depending on the polarity of the demodulator. The demodulation polarity is switched via the I<sup>2</sup>C-bus. The AGC detector time-constant capacitor is connected externally (this mainly because of the flexibility of the application). The time-constant of the AGC system during positive modulation is rather long to avoid visible variations of the signal amplitude. To obtain an acceptable speed of the AGC system a circuit has been included which detects whether the AGC detector is activated every frame period. When during 3 frame periods no action is detected the speed of the system is increased.

The circuit contains a video identification circuit which is independent of the synchronization circuit. Therefore search tuning is possible when the display section of the receiver is used as a monitor. The identification output is supplied to the tuning system via the I<sup>2</sup>C-bus. The information of this identification circuit can also be used to switch the phase-1 ( $\phi_1$ ) loop to a low gain when no signal is received so that a stable OSD display is obtained. The coupling of the video identification circuit with the  $\phi_1$  loop can be switched on and off via the I<sup>2</sup>C-bus.

#### Synchronization circuit

The sync separator is preceded by a controlled amplifier which adjusts the sync pulse amplitude to a fixed level. These pulses are fed to the slicing stage which is operating at 50% of the amplitude.

The separated sync pulses are fed to the first phase detector and to the coincidence detector. This coincidence detector is only used to detect whether the line oscillator is synchronized and not for transmitter identification. The first Phase-Locked Loop (PLL) has a very high-statical steepness so that the phase of the picture is independent of the line frequency.

The line oscillator is running at twice the line frequency. The oscillator capacitor is internal. Because of the spreads of internal components an automatic adjustment circuit has been added to the IC. It compares the oscillator frequency with that of the crystal oscillator in the colour decoder.

To protect the horizontal output transistor the horizontal drive is switched-off when a power-on-reset is detected. The frequency of the oscillator is calibrated again when all subaddress bytes have been sent. When the oscillator has the right frequency the calibration stops and the horizontal drive is switched-on again via the soft start procedure (standby bit in normal mode). When the IC is switched-on the same procedure is followed.

When the coincidence detector indicates an out-of-lock situation the calibration procedure is repeated.

The circuit has a second control loop to generate the drive pulses for the horizontal driver stage. During the start-up procedure the duty cycle of the horizontal output pulse increases from 0 to 50% in approximately 100 lines.

The vertical sawtooth generator drives the vertical output and EW correction drive circuits. The geometry processing circuits provide control of horizontal shift, EW width, EW parabola/width ratio, EW corner/parabola ratio, trapezium correction, vertical shift, vertical slope, vertical amplitude, and the S-correction. All these controls can be set via the I<sup>2</sup>C-bus. The geometry processor has a differential current



## I<sup>2</sup>C-bus controlled PAL/NTSC TV processor

TDA8366

output for the vertical drive signal and a single-ended output for the EW drive. Both the vertical drive and the EW drive outputs can be modulated for EHT compensation. The EHT compensation pin is also used for overvoltage protection.

The geometry processor also offers the possibilities for vertical compression (for display of 16 : 9 pictures on a 4 : 3 screen) and vertical expansion (for display of 4 : 3 pictures on a 16 : 9 screen with full picture width, or for display of 'letter-box' transmissions on a 4 : 3 screen with full picture height). For the expand mode it is possible to shift the picture vertically (only one fixed position).

Also the de-interlace of the vertical output can be set via the I<sup>2</sup>C-bus.

To avoid damage of the picture tube when the vertical deflection fails the guard output current of the TDA8350 can be supplied to the sandcastle output. When a failure is detected the RGB-outputs are blanked and a bit is set (NDF) in the status byte of the I<sup>2</sup>C-bus. When no vertical deflection output stage is connected this guard circuit will also blank the output signals. This can be overruled by means of the EVG bit of subaddress 0A (see Table 1).

### Integrated video filters

The circuit contains a chrominance bandpass and trap circuit. The chrominance trap filter in the luminance path is designed for a symmetrical step response behaviour. The filters are realized by means of gyrator circuits and they are automatically tuned by comparing the tuning frequency with the crystal frequency of the decoder. The luminance delay line and the delay for the peaking circuit are also realized by means of gyrator circuits.

It is possible to connect a Colour Transient Improvement (CTI) or Picture Signal Improvement (PSI) IC to the TDA8366. Therefore the luminance signal which has passed the filter and delay line circuit is externally available. The output signal of the transient improvement circuit must be supplied to the luminance input circuit. When the CTI function is not required the two pins must be AC-coupled.

### Video switches

The circuit has two CVBS inputs and an Super-Video Home System (S-VHS) input. The input can be chosen by the I<sup>2</sup>C-bus. The input selector also has a position in which CVBS<sub>EXT</sub> is processed, unless there is a signal on the S-VHS input. When the input selector is in this position it switches to the S-VHS input if the S-VHS detector detects sync pulses on the S-VHS luminance input. The S-VHS detector output can be read by the I<sup>2</sup>C-bus. When the S-VHS option is not used the luminance input can be used as a second input for external CVBS signals. The choice is made via the CVS-bit (see Table 1).

The video switch circuit has two outputs which can be programmed in a different way. The input signal for the decoder is also available on the TXT output. Therefore this signal can be used to drive the teletext decoder and the SECAM add-on decoder. The signal on the PIP output can be chosen independent of the TXT output. If S-VHS is selected for one of the outputs the luminance and chrominance signals are added so that a CVBS signal is obtained again.

### Colour decoder

The colour decoder contains an alignment-free crystal oscillator, a killer circuit and the colour difference demodulators. The 90° phase shift for the reference signal is made internally. The demodulation angle and gain ratio for the colour difference signals for PAL and NTSC are adapted to the standard.

The colour decoder is very flexible. Together with the SECAM decoder TDA8395 an automatic multistandard decoder can be designed.

Which standard the IC can decode depends on the external crystals. If a 4.4 MHz and a 3.5 MHz crystal are used PAL 4.4, NTSC 4.4, NTSC 3.5 and PAL 3.5 can be decoded. If two 3.5 MHz crystals are used PAL N and M can be decoded. If one crystal is connected only PAL/NTSC 4.4 or PAL/NTSC 3.5 can be decoded. The crystal frequency of the decoder is used to tune the line oscillator. Therefore the value of the crystal frequency must be given to the IC via the I<sup>2</sup>C-bus.

## I<sup>2</sup>C-bus controlled PAL/NTSC TV processor

TDA8366

### RGB output circuit and black-current stabilization

The colour-difference signals are matrixed with the luminance signal to obtain the RGB-signals. For the RGB-inputs linear amplifiers have been chosen so that the circuit is suited for signals coming from the SCART connector. The contrast and brightness control operate on internal and external signals.

The output signal has an amplitude of approximately 2 V black-to-white at nominal input signals and nominal settings of the controls.

The black current stabilization is realized by means of a feedback from the video output amplifiers to the RGB control circuit. The 'black current' of the 3 guns of the picture tube is internally measured and stabilized. The black level control is active during 4 lines at the end of the vertical blanking. During the first line the leakage current is measured and the following 3 lines the 3 guns are adjusted to the required level. The maximum acceptable leakage current is  $\pm 100 \mu\text{A}$ . The nominal value of the 'black current' is  $10 \mu\text{A}$ . The ratio of the currents for the various guns automatically tracks with the white point adjustment so that the back-ground colour is the same as the adjusted white point.

The input impedance of the 'black-current' measuring pin is  $15 \text{ k}\Omega$ . Therefore the beam current during scan will cause the input voltage to exceed the supply voltage. The internal protection will start conducting so that the excessive current is bypassed.

When the TV receiver is switched-on the black current stabilization circuit is not active, the RGB outputs are blanked and beam current limiting input pin is short-circuited. Only during the measuring lines will the outputs supply a voltage of 5 V to the video output stage so that it can be detected if the picture tube is warming up. These pulses are switched-on after a waiting time of approximately 0.5 s. This ensures that the vertical deflection is activated so that the measuring pulses are not

visible on the screen. As soon as the current supplied to the measuring input exceeds a value of  $190 \mu\text{A}$  the stabilization circuit is activated. After a waiting time of approximately 0.8 s the blanking and the beam current limiting input pin are released. The remaining switch-on behaviour of the picture is determined by the external time constant of the beam current limiting network.

### I<sup>2</sup>C-BUS SPECIFICATION

A6	A5	A4	A3	A2	A1	A0	R/W
1	0	0	0	1	0	1	X

MLA743

X = don't care.

Fig.4 Slave address (8A).

Valid subaddresses: 00 to 13; subaddress FE is reserved for test purposes. Auto-increment mode is available for subaddresses.

### Start-up procedure

Read the status bytes until POR = 0 and send all subaddress bytes. The horizontal output signal is switched-on when the oscillator is calibrated. It is possible to have the horizontal output signal available before calibration. Then the SFM bit must be set to logic 0.

Each time before the data in the IC is refreshed, the status bytes must be read. If POR = 1, the procedure mentioned above must be carried out to restart the IC.

When this procedure is not followed the horizontal frequency may be incorrect after power-up or after a power dip.

## I<sup>2</sup>C-bus controlled PAL/NTSC TV processor

TDA8366

### Inputs

**Table 1** Input status bits; note 1

FUNCTION	SUBADDRESS (HEX)	DATA BYTE							
		D7	D6	D5	D4	D3	D2	D1	D0
Source select	00	INA	INB	INC	IND	FOA	FOB	XA	XB
Decoder mode	01	FORF	FORS	DL	STB	POC	CM2	CM1	CM0
Hue	02	X	X	A5	A4	A3	A2	A1	A0
Horizontal shift (HS)	03	X	X	A5	A4	A3	A2	A1	A0
EW width (EW)	04	X	X	A5	A4	A3	A2	A1	A0
EW parabola/width (PW)	05	X	X	A5	A4	A3	A2	A1	A0
EW corner parabola (CP)	06	X	X	A5	A4	A3	A2	A1	A0
EW trapezium (TC)	07	X	X	A5	A4	A3	A2	A1	A0
Vertical slope (VS)	08	NCIN	X	A5	A4	A3	A2	A1	A0
Vertical amplitude (VA)	09	VID	LBM	A5	A4	A3	A2	A1	A0
S-correction (SC)	0A	HCO	EVG	A5	A4	A3	A2	A1	A0
Vertical shift (VSH)	0B	SBL	PRD	A5	A4	A3	A2	A1	A0
White point R	0C	EXP	CL	A5	A4	A3	A2	A1	A0
White point G	0D	SFM	CVS	A5	A4	A3	A2	A1	A0
White point B	0E	MAT	PHL	A5	A4	A3	A2	A1	A0
Peaking	0F	YD3	YD2	YD1	YD0	A3	A2	A1	A0
Brightness	10	RBL	COR	A5	A4	A3	A2	A1	A0
Saturation	11	IE1	X	A5	A4	A3	A2	A1	A0
Contrast	12	AFW	IFS	A5	A4	A3	A2	A1	A0
AGC take-over	13	MOD	VSW	A5	A4	A3	A2	A1	A0

### Note

1. X = don't care.

**Table 2** Output status bits; note 1

FUNCTION	SUBADDRESS (HEX)	DATA BYTE							
		D7	D6	D5	D4	D3	D2	D1	D0
Output status bytes	00	POR	FSI	STS	SL	XPR	CD2	CD1	CD0
	01	NDF	IN1	X	IFI	AFA	AFB	X	X

### Note

1. X = don't care.

## I<sup>2</sup>C-bus controlled PAL/NTSC TV processor

TDA8366

## INPUT CONTROL BITS

**Table 3** Source select 1

INA	INB	DECODER AND TXT
0	0	CVBS <sub>INT</sub>
0	1	CVBS <sub>EXT</sub>
1	0	S-VHS
1	1	S-VHS (CVBS <sub>EXT</sub> )

**Table 4** Source select 2

INC	IND	PIP
0	0	CVBS <sub>INT</sub>
0	1	CVBS <sub>EXT</sub>
1	0	S-VHS
1	1	S-VHS (CVBS <sub>EXT</sub> )

**Table 5** Phase 1 ( $\phi_1$ ) time constant

FOA	FOB <sup>(1)</sup>	MODE
0	0	normal
0	1	slow
1	X	fast

**Note**

1. X = don't care.

**Table 6** Crystal indication

XA	XB	CRYSTAL
0	0	two 3.6 MHz
0	1	one 3.6 MHz (pin 32)
1	0	one 4.4 MHz (pin 33)
1	1	3.6 MHz (pin 32) and 4.4 MHz (pin 33)

**Table 7** Forced field frequency

FORF	FORS	FIELD FREQUENCY
0	0	auto (60 Hz when line not synchronized)
0	1	60 Hz; note 1
1	0	50 Hz; note 1
1	1	auto (50 Hz when line not synchronized)

**Note**

1. When the forced mode is selected the divider will only switch to that position when the horizontal oscillator is not synchronized.

**Table 8** Interlace

DL	STATUS
0	interlace
1	de-interlace

**Table 9** Standby

STB	MODE
0	standby
1	normal

**Table 10** Synchronization mode

POC	MODE
0	active
1	not active

**Table 11** Colour decoder mode

CM2	CM1	CM0	DECODER MODE
0	0	0	not forced, own intelligence
0	0	1	forced NTSC 3.6 MHz
0	1	0	forced PAL 4.4 MHz
0	1	1	forced SECAM
1	0	0	forced NTSC 4.4 MHz
1	0	1	forced PAL 3.6 MHz (pin 32)
1	1	0	forced PAL 3.6 MHz (pin 33)
1	1	1	no function

## I<sup>2</sup>C-bus controlled PAL/NTSC TV processor

TDA8366

**Table 12** Vertical divider mode

NCIN	VERTICAL DIVIDER MODE
0	normal operation
1	switched to search window

**Table 13** Video ident mode

VID	VIDEO IDENT MODE
0	$\phi_1$ loop switched on and off
1	not active

**Table 14** Long blanking mode

LBM	BLANKING MODE
0	adapted to standard (50 or 60 Hz)
1	fixed in accordance with 50 Hz standard

**Table 15** EHT tracking mode

HCO	TRACKING MODE
0	EHT tracking only on vertical
1	EHT tracking on vertical and EW

**Table 16** Enable vertical guard (RGB blanking)

EVG	VERTICAL GUARD MODE
0	not active
1	active

**Table 17** Service blanking

SBL	SERVICE BLANKING MODE
0	off
1	on

**Table 18** Overvoltage input mode

PRD	OVERVOLTAGE MODE
0	detection mode
1	protection mode

**Table 19** Vertical deflection mode

EXP	CL	VERTICAL DEFLECTION MODE
0	0	normal
0	1	compress
1	0	expand
1	1	expand and lift

**Table 20** Horizontal frequency during switch-on

SFM	START-UP FREQUENCY
0	maximum
1	nominal

**Table 21** Condition Y/C input

CVS	Y-INPUT MODE
0	switched to Y/C mode
1	switched to CVBS mode

**Table 22** PAL/NTSC matrix

MAT	MATRIX
0	adapted to standard
1	PAL

**Table 23** Colour crystal PLL

PHL	STATE
0	PLL closed
1	oscillator free-running

**Table 24** Y-delay adjustment; note 1

YD0 to YD3	Y-DELAY
YD3	YD3 * 160 ns +
YD2	YD2 * 80 ns +
YD1	YD1 * 40 ns +
YD0	YD0 * 40 ns

**Note**

- For an equal delay of the luminance and chrominance signal the delay must be set at a value of 160 ns. This is only valid for a CVBS signal without group delay distortions.

**Table 25** RGB blanking

RBL	RGB BLANKING
0	not active
1	active

**Table 26** Noise coring (peaking)

COR	NOISE CORING
0	off
1	on

## I<sup>2</sup>C-bus controlled PAL/NTSC TV processor

TDA8366

**Table 27** Enable fast blanking

IE1	FAST BLANKING
0	not active
1	active

**Table 28** AFC window

AFW	AFC WINDOW
0	normal
1	enlarged

**Table 29** IF sensitivity

IFS	IF SENSITIVITY
0	normal
1	reduced

**Table 30** Modulation standard

MOD	MODULATION
0	negative
1	positive

**Table 31** Video mute

VSW	STATE
0	normal operation
1	IF-video signal switched off

## OUTPUT CONTROL BITS

**Table 32** Power-on-reset

POR	MODE
0	normal
1	power-down

**Table 33** Field frequency indication

FSI	FREQUENCY
0	50 Hz
1	60 Hz

**Table 34** S-VHS status

STS	S-VHS INPUT
0	no signal
1	signal

**Table 35** Phase 1 ( $\phi_1$ ) lock indication

SL	INDICATION
0	not locked
1	locked

**Table 36** X-ray protection

XPR	OVERVOLTAGE
0	no overvoltage detected
1	overvoltage detected

**Table 37** Colour decoder mode

CD2	CD1	CD0	STANDARD
0	0	0	no colour standard identified
0	0	1	NTSC 3.6 MHz
0	1	0	PAL 4.4 MHz
0	1	1	SECAM
1	0	0	NTSC 4.4 MHz
1	0	1	PAL 3.6 MHz (pin 32)
1	1	0	PAL 3.6 MHz (pin 33)
1	1	1	spare

**Table 38** Output vertical guard

NDF	VERTICAL OUTPUT STAGE
0	OK
1	failure

**Table 39** Indication RGB insertion

IN1	RGB INSERTION
0	no (pin 24 LOW)
1	yes (pin 24 HIGH)

**Table 40** Output video identification

IFI	VIDEO SIGNAL
0	no video signal identified
1	video signal identified

## I<sup>2</sup>C-bus controlled PAL/NTSC TV processor

TDA8366

**Table 41** AFC output

AFA	AFB	CONDITION
0	0	outside window; too low
0	1	outside window; too high
1	0	in window; below reference
1	1	in window; above reference

**LIMITING VALUES**

In accordance with the Absolute Maximum Rating System (IEC 134).

SYMBOL	PARAMETER	CONDITIONS	MIN.	MAX.	UNIT
V <sub>P</sub>	supply voltage		–	9.0	V
T <sub>stg</sub>	storage temperature		–25	+150	°C
T <sub>amb</sub>	operating ambient temperature		0	70	°C
T <sub>sol</sub>	soldering temperature	for 5 s	–	260	°C
T <sub>j</sub>	operating junction temperature		–	150	°C
V <sub>es</sub>	electrostatic handling	HBM; all pins; notes 1 and 2	–2000	+2000	V
		MM; all pins; notes 1 and 3	–200	+200	V

**Notes**

- All pins are protected against ESD by means of internal clamping diodes.
- Human Body Model (HBM): R = 1.5 kΩ; C = 100 pF.
- Machine Model (MM): R = 0 Ω; C = 200 pF.

**THERMAL CHARACTERISTICS**

SYMBOL	PARAMETER	VALUE	UNIT
R <sub>th j-a</sub>	thermal resistance from junction to ambient in free air		
	SDIP52	40	K/W
	QFP64	50	K/W

**QUALITY SPECIFICATION**

In accordance with "SNW-FQ-611E". The number of the quality specification can be found in the "Quality Reference Handbook". The handbook can be ordered using the code 9398 510 63011.

**Latch-up**

- I<sub>trigger</sub> ≥ 100 mA or ≥ 1.5V<sub>DD(max)</sub>
- I<sub>trigger</sub> ≤ –100 mA or ≤ –0.5V<sub>DD(max)</sub>

Following pins do not meet the above specification:

- Pin 7: –90 mA
- Pin 17: 90 mA
- Pin 18: 90 mA
- Pin 19: 90 mA
- Pin 24: –90 mA
- Pin 34: 60 mA
- Pin 49: –90 mA
- Pin 50: ±90 mA.

## I<sup>2</sup>C-bus controlled PAL/NTSC TV processor

TDA8366

### CHARACTERISTICS

$V_P = 8\text{ V}$ ;  $T_{\text{amb}} = 25\text{ °C}$ ; unless otherwise specified.

SYMBOL	PARAMETER	CONDITIONS	MIN.	TYP.	MAX.	UNIT
<b>Supplies</b>						
MAIN SUPPLY (PIN 10)						
$V_{P1}$	supply voltage		7.2	8.0	8.8	V
$I_{P1}$	supply current		–	100	–	mA
$P_{\text{tot}}$	total power dissipation		–	850	–	W
HORIZONTAL OSCILLATOR SUPPLY (PIN 35)						
$V_{P2}$	supply voltage		7.2	8.0	8.8	V
$I_{P2}$	supply current		–	6	–	mA
<b>IF circuit</b>						
VISION IF AMPLIFIER INPUTS (PINS 46 AND 47)						
$V_{i(\text{rms})}$	input sensitivity (RMS value)	note 1 $f_i = 38.90\text{ MHz}$ $f_i = 45.75\text{ MHz}$ $f_i = 58.75\text{ MHz}$	– – –	70 70 70	100 100 100	$\mu\text{V}$ $\mu\text{V}$ $\mu\text{V}$
$R_i$	input resistance (differential)	note 2	–	2	–	k $\Omega$
$C_i$	input capacitance (differential)	note 2	–	3	–	pF
$G_{\text{cr}}$	gain control range		64	–	–	dB
$V_{i\text{ max}(\text{rms})}$	maximum input signal (RMS value)		100	150	–	mV
VIDEO AMPLIFIER OUTPUT (PIN 4); note 3						
$V_o$	zero signal output level	negative modulation; note 4	–	4.7	–	V
		positive modulation; note 4	–	2.0	–	V
$V_4$	top sync level	negative modulation	1.9	2.0	2.1	V
$V_4$	white level	positive modulation	–	4.5	–	V
$\Delta V_4$	difference in amplitude between negative and positive modulation		–	0	15	%
$Z_o$	video output impedance		–	50	–	$\Omega$
$I_{\text{bias}}$	internal bias current of NPN emitter follower output transistor		1.0	–	–	mA
$I_{\text{source}(\text{max})}$	maximum source current		–	–	5	mA
$B$	bandwidth of demodulated output signal	at –3 dB	6	9	–	MHz
$G_{\text{diff}}$	differential gain	note 5	–	2	5	%
$\phi_{\text{diff}}$	differential phase	notes 5 and 6	–	–	5	deg
$NL_{\text{vid}}$	video non-linearity	note 7	–	–	5	%
$V_{\text{th}}$	white spot threshold level		–	5.0	–	V
$V_{\text{ins}}$	white spot insertion level		–	3.3	–	V



## I<sup>2</sup>C-bus controlled PAL/NTSC TV processor

TDA8366

SYMBOL	PARAMETER	CONDITIONS	MIN.	TYP.	MAX.	UNIT
VIDEO AMPLIFIER OUTPUT (CONTINUED)						
N <sub>clamp</sub>	noise inverter clamping level		–	1.4	–	V
N <sub>ins</sub>	noise inverter insertion level (identical to black level)		–	2.6	–	V
δ <sub>mod</sub>	intermodulation blue	notes 6 and 8				
		V <sub>o</sub> = 0.92 or 1.1 MHz	60	66	–	dB
	yellow	V <sub>o</sub> = 2.66 or 3.3 MHz	60	66	–	dB
		V <sub>o</sub> = 0.92 or 1.1 MHz	56	62	–	dB
		V <sub>o</sub> = 2.66 or 3.3 MHz	60	66	–	dB
S/N	signal-to-noise ratio	notes 6 and 9				
		V <sub>i</sub> = 10 mV	52	60	–	dB
		end of control range	52	61	–	dB
V <sub>4</sub>	residual carrier signal	note 6	–	5.5	–	mV
V <sub>4</sub>	residual 2nd harmonic of carrier signal	note 6	–	2.5	–	mV
IF AND TUNER AGC; note 10						
<i>timing of IF-AGC with a 2.2 μF capacitor (pin 51)</i>						
	modulated video interference	30% AM for 1 mV to 100 mV; 0 to 200 Hz (system B/G)	–	–	10	%
t <sub>inc</sub>	response time to an IF input signal amplitude increase of 52 dB	positive and negative modulation	–	2	–	ms
t <sub>dec</sub>	response to an IF input signal amplitude decrease of 52 dB	negative modulation	–	50	–	ms
		positive modulation	–	100	–	ms
I <sub>L</sub>	allowed leakage current of the AGC capacitor	negative modulation	–	–	10	μA
		positive modulation	–	–	200	nA
<i>Tuner take-over adjustment (via I<sup>2</sup>C-bus)</i>						
V <sub>51min(rms)</sub>	minimum starting level for tuner take-over (RMS value)		–	0.4	0.8	mV
V <sub>51max(rms)</sub>	maximum starting level for tuner take-over (RMS value)		40	80	–	mV
<i>Tuner control output (pin 52)</i>						
V <sub>52max</sub>	maximum tuner AGC output voltage	maximum tuner gain; note 2	–	–	V <sub>P</sub> + 1	V
V <sub>52(sat)</sub>	output saturation voltage	minimum tuner gain; I <sub>47</sub> = 2 mA	–	–	300	mV
I <sub>52max</sub>	maximum tuner AGC output swing		5	–	–	mA
I <sub>L</sub>	leakage current RF AGC		–	–	1	μA
ΔV <sub>i</sub>	input signal variation for complete tuner control		0.5	2	4	dB

**I<sup>2</sup>C-bus controlled PAL/NTSC TV  
processor**

TDA8366

SYMBOL	PARAMETER	CONDITIONS	MIN.	TYP.	MAX.	UNIT
<b>AFC OUTPUT (VIA I<sup>2</sup>C-BUS); note 11</b>						
RES	AFC resolution		–	2	–	bits
W <sub>sen</sub>	window sensitivity		65	80	100	kHz
W <sub>senL</sub>	window sensitivity in large window mode		195	240	300	kHz
f <sub>os</sub>	AFC offset	note 6	–	–	50	kHz
<b>VIDEO IDENTIFICATION OUTPUT (VIA I<sup>2</sup>C-BUS)</b>						
t <sub>d</sub>	delay time of identification after the AGC has stabilized on a new transmitter		–	–	10	ms
<b>CVBS and S-VHS input switch</b>						
<b>INTERNAL AND EXTERNAL CVBS INPUTS (PINS 11 AND 15)</b>						
V <sub>11(p-p)</sub>	CVBS input voltage (peak-to-peak value)	note 12	–	1.0	1.4	V
I <sub>11</sub>	CVBS input current		–	4	–	μA
SS <sub>CVBS</sub>	suppression of non-selected CVBS input signal	notes 6 and 13	50	–	–	dB
<b>S-VHS INPUT (PINS 8 AND 9)</b>						
V <sub>9(p-p)</sub>	luminance input voltage (peak-to-peak value)		–	1.0	1.4	V
I <sub>9(p-p)</sub>	luminance input current		–	4	–	μA
V <sub>8</sub>	chrominance input voltage (burst amplitude)	note 14	–	0.3	0.45	V
I <sub>8</sub>	chrominance input current		–	4	–	μA
<b>TXT AND PIP OUTPUT SIGNALS (PINS 36 AND 13)</b>						
V <sub>o(p-p)</sub>	output signal amplitude (peak-to-peak value)		–	1.0	–	V
Z <sub>o</sub>	output impedance		–	–	250	Ω
V <sub>TS</sub>	top sync level		–	2.5	–	V

## I<sup>2</sup>C-bus controlled PAL/NTSC TV processor

TDA8366

SYMBOL	PARAMETER	CONDITIONS	MIN.	TYP.	MAX.	UNIT
<b>RGB inputs, colour difference inputs, luminance inputs and outputs</b>						
RGB INPUTS (PINS 21, 22 AND 23)						
$V_{21,22,23(p-p)}$	input signal amplitude for an output signal of 2 V (black-to-white) (peak-to-peak value)	note 15	–	0.7	0.8	V
$V_{21,22,23(p-p)}$	input signal amplitude before clipping occurs (peak-to-peak value)	note 6	1.0	–	–	V
$\Delta V_o$	difference between black level of internal and external signals at the outputs		–	–	20	mV
$I_{21,22,23}$	input currents	no clamping; note 2	–	–	0.5	$\mu$ A
$\Delta t_d$	delay difference for the three channels	note 6	–	0	20	ns
FAST BLANKING (PIN 24)						
$V_i$	input voltage	no data insertion	–	–	0.4	V
		data insertion	0.9	–	–	V
$V_{24(max)}$	maximum input pulse	insertion	–	–	3.0	V
$t_d$	delay time from RGB in to RGB out	data insertion; note 6	–	100	–	ns
$\Delta t_d$	delay difference between insertion to RGB out and RGB in to RGB out	data insertion; note 6	–	50	–	ns
$I_{24}$	input current		–	–	0.2	mA
$SS_{int}$	suppression of internal RGB signals	notes 6 and 12; insertion; $f_i = 0$ to 5 MHz	55	–	–	dB
$SS_{ext}$	suppression of external RGB signals	notes 6 and 12; no insertion; $f_i = 0$ to 5 MHz	55	–	–	dB
$V_i$	input voltage to blank the RGB outputs to facilitate 'On Screen Display' signals being applied to the outputs		4	–	–	V
COLOUR DIFFERENCE INPUT SIGNALS (PINS 29 AND 30)						
$V_{30(p-p)}$	input signal amplitude (R–Y) (peak-to-peak value)	note 2	–	1.05	–	V
$V_{29(p-p)}$	input signal amplitude (B–Y) (peak-to-peak value)	note 2	–	1.35	–	V
$I_{29,30}$	input current for both inputs	note 2	–	0.1	1.0	$\mu$ A

## I<sup>2</sup>C-bus controlled PAL/NTSC TV processor

TDA8366

SYMBOL	PARAMETER	CONDITIONS	MIN.	TYP.	MAX.	UNIT
<b>LUMINANCE INPUTS AND OUTPUTS (PINS 25 AND 26)</b>						
V <sub>26(p-p)</sub>	output signal amplitude (peak-to-peak value)	top sync-white	–	0.45	0.63	V
V <sub>TS</sub>	top sync level		–	2.5	–	V
Z <sub>o</sub>	output impedance		–	250	–	Ω
V <sub>25(p-p)</sub>	input signal amplitude (peak-to-peak value)		–	0.45	–	V
I <sub>clamp</sub>	clamp current	during burst key pulse	–	200	–	μA
I <sub>i</sub>	input current	no clamp	–	–	0.5	μA
<b>Chrominance filters</b>						
<b>CHROMINANCE TRAP CIRCUIT</b>						
f <sub>trap</sub>	trap frequency		–	f <sub>osc</sub>	–	MHz
QF	trap quality factor	note 16	–	2	–	
SR	colour subcarrier rejection		20	–	–	dB
<b>CHROMINANCE BANDPASS CIRCUIT</b>						
f <sub>c</sub>	centre frequency		–	f <sub>osc</sub>	–	MHz
QBP	bandpass quality factor		–	3	–	
<b>Delay line and peaking circuit</b>						
<b>Y DELAY LINE</b>						
t <sub>d</sub>	delay time	note 6	–	480	–	ns
t <sub>d1</sub>	tuning range delay time	8 steps	–160	–	+160	ns
B	bandwidth of internal delay line	note 6	5	–	–	MHz
<b>PEAKING CONTROL; note 17</b>						
f <sub>c(p)</sub>	peaking centre frequency		–	3	–	MHz
t <sub>w</sub>	width of preshoot or overshoot	note 2	–	160	–	ns
OS	overshoot	positive	–	20	–	%
		negative	–	36	–	%
	peaking control curve	16 steps		see Fig.5		
<b>CORING STAGE</b>						
S	coring range		–	15	–	IRE
G <sub>w</sub>	wave gain	negative half wave gain positive half wave gain	–	1.8	–	
<b>Horizontal synchronization circuits</b>						
<b>SYNC VIDEO INPUT (PINS 9, 11 AND 15)</b>						
V <sub>9,11,15</sub>	sync pulse amplitude	note 2	50	300	–	mV
SL <sub>HS</sub>	slicing level for horizontal sync	note 18	–	50	–	%
SL <sub>VS</sub>	slicing level for vertical sync		–	30	–	%

## I<sup>2</sup>C-bus controlled PAL/NTSC TV processor

TDA8366

SYMBOL	PARAMETER	CONDITIONS	MIN.	TYP.	MAX.	UNIT
HORIZONTAL OSCILLATOR						
$f_{fr}$	free running frequency		–	15625	–	Hz
$\Delta f_{fr}$	spread on free running frequency		–	–	$\pm 2$	%
$\Delta f/\Delta V_P$	frequency variation with respect to the supply voltage	$V_P = 8.0 \text{ V} \pm 10\%$ ; note 6	–	0.2	0.5	%
$\Delta f_{(max)}$	frequency variation with temperature	$T_{amb} = 0 \text{ to } 70 \text{ }^\circ\text{C}$ ; note 6	–	–	80	Hz
$\Delta f_{osc(max)}$	maximum frequency deviation at the start of the horizontal output		–	–	75	%
FIRST CONTROL LOOP (FILTER CONNECTED TO PIN 41); note 19						
$f_{HR}$	holding range PLL		–	$\pm 0.9$	$\pm 1.2$	kHz
$f_{CR}$	catching range PLL	note 6	$\pm 0.6$	$\pm 0.9$	–	kHz
S/N	signal-to-noise ratio of the video input signal at which the time constant is switched		–	20	–	dB
HYS	hysteresis at the switching point		–	1	–	dB
SECOND CONTROL LOOP (CAPACITOR CONNECTED TO PIN 40)						
$\Delta\phi/\Delta\phi_0$	control sensitivity		–	150	–	$\mu\text{s}/\mu\text{s}$
$t_{cr}$	control range from start of horizontal output to flyback at nominal shift position		11	12	–	$\mu\text{s}$
$t_{shift}$	horizontal shift range	63 steps	$\pm 2$	–	–	$\mu\text{s}$
	control sensitivity for dynamic compensation		–	5.3	–	$\mu\text{s}/\text{V}$
HORIZONTAL OUTPUT (PIN 38); note 20						
$V_{OL}$	LOW level output voltage	$I_O = 10 \text{ mA}$	–	–	0.3	V
$I_{O(max)}$	maximum allowed output current		10	–	–	mA
$V_{O(max)}$	maximum allowed output voltage		–	–	$V_P$	V
$\delta$	duty factor	note 6	–	50	–	%
FLYBACK PULSE INPUT (PIN 39)						
$V_{HSW}$	switching level for horizontal blanking		–	0.4	–	V
$V_{\phi 2(SW)}$	switching level for phase-2 loop		–	4.0	–	V
$V_{39(max)}$	maximum input voltage	note 2	–	8.0	–	V
$Z_i$	input impedance	note 2	–	10	–	M $\Omega$

## I<sup>2</sup>C-bus controlled PAL/NTSC TV processor

TDA8366

SYMBOL	PARAMETER	CONDITIONS	MIN.	TYP.	MAX.	UNIT
SANDCASTLE PULSE OUTPUT (PIN 37)						
V <sub>37</sub>	output voltage	during burst key	4.8	5.3	5.8	V
		during blanking	1.8	2.0	2.2	V
t <sub>w</sub>	pulse width	burst key pulse	3.3	3.5	3.7	μs
		vertical blanking (50 Hz)	–	25	–	lines
		vertical blanking (60 Hz)	–	21	–	lines
V <sub>clamp</sub>	clamp level for vertical guard detection		–	2.7	–	V
I <sub>37(min)</sub>	minimum input current to activate guard detection		–	–	0.5	mA
I <sub>37(max)</sub>	maximum allowable input current		2.5	–	–	mA
t <sub>d</sub>	delay of start of burst key to start of sync		–	5.4	–	μs
SOFT START; note 21						
δ <sub>df</sub>	duty factor control range		0	–	50	%
t <sub>ss</sub>	soft start time		–	100	–	lines
<b>Vertical synchronization and geometry correction</b>						
VERTICAL OSCILLATOR; note 22						
f <sub>fr</sub>	free running frequency		–	50/60	–	Hz
f <sub>lock</sub>	locking range		45	–	64.5	Hz
	divider value not locked		–	625/525	–	lines
	locking range		488	–	722	lines/frame
VERTICAL RAMP GENERATOR (PIN 49)						
V <sub>49(p-p)</sub>	sawtooth amplitude (peak-to-peak value)	VS = 1FH; C = 100 nF; R = 39 kΩ	–	3.5	–	V
I <sub>dis</sub>	discharge current		–	1	–	mA
I <sub>charge</sub>	charge current set by external resistor	note 23	–	19	–	μA
VS	vertical slope	control range (63 steps)	–14	–	+14	%
		compress mode	–	75	–	%
		expand mode	–	133	–	%
ΔI <sub>49</sub>	charge current increase	f = 60 Hz	–	20	–	%
V <sub>49L</sub>	LOW level of ramp	normal or expand mode	–	2.07	–	V
		compress mode	–	2.55	–	V
VERTICAL DRIVE OUTPUTS (PINS 44 AND 45)						
I <sub>diff(p-p)</sub>	differential output current (peak-to-peak value)	VA = 1FH	–	1	–	mA
I <sub>CM</sub>	common mode current		–	400	–	μA
V <sub>o</sub>	output voltage range		0	–	4.0	V

## I<sup>2</sup>C-bus controlled PAL/NTSC TV processor

TDA8366

SYMBOL	PARAMETER	CONDITIONS	MIN.	TYP.	MAX.	UNIT
EHT TRACKING/OVERVOLTAGE PROTECTION (PIN 48)						
$\Delta V_{48}$	input voltage		1.2	–	2.8	V
SMR	scan modulation range		–6	–	+6	%
$\Phi_{\text{vert}}$	vertical sensitivity		–	7.5	–	%/V
$\Phi_{\text{EW}}$	EW sensitivity	when switched-on	–	–7.5	–	%/V
$I_{\text{eq}}$	EW equivalent output current		+120	–	–120	$\mu\text{A}$
$V_{48}$	overvoltage detection level		–	3.9	–	V
DE-INTERLACE						
	first field delay		–	0.5H	–	
EW WIDTH						
CR	control range	63 steps	100	–	80	%
$I_{\text{eq}}$	equivalent output current		0	–	400	$\mu\text{A}$
$V_{\text{o}}$	EW output voltage range		1.0	–	8.0	V
$I_{\text{o}}$	EW output current range		0	–	900	$\mu\text{A}$
EW PARABOLA/WIDTH						
CR	control range	63 steps	0	–	24	%
$I_{\text{eq}}$	equivalent output current	EW = 3FH	0	–	480	$\mu\text{A}$
EW CORNER/PARABOLA						
CR	control range	63 steps	–44	–	0	%
$I_{\text{eq}}$	equivalent output current	PW = 3FH; EW = 3FH	–210	–	0	$\mu\text{A}$
EW TRAPEZIUM						
CR	control range	63 steps	–4	–	+4	%
$I_{\text{eq}}$	equivalent output current		–80	–	+80	$\mu\text{A}$
VERTICAL AMPLITUDE						
CR	control range	63 steps; SC = 00H	80	–	120	%
		63 steps; SC = 3FH	86	–	112	%
$I_{\text{eqdiff(p-p)}}$	equivalent differential vertical drive output current (peak-to-peak value)	SC = 00H	800	–	1200	$\mu\text{A}$
VERTICAL SHIFT						
CR	control range	63 steps	–4	–	+4	%
$I_{\text{eqdiff(p-p)}}$	equivalent differential vertical drive output current (peak-to-peak value)		–40	–	+40	$\mu\text{A}$
S-CORRECTION						
CR	control range	63 steps	0	–	25	%

## I<sup>2</sup>C-bus controlled PAL/NTSC TV processor

TDA8366

SYMBOL	PARAMETER	CONDITIONS	MIN.	TYP.	MAX.	UNIT
<b>Colour demodulation part</b>						
CHROMINANCE AMPLIFIER						
ACC <sub>cr</sub>	ACC control range	note 24	26	–	–	dB
ΔV	change in amplitude of the output signals over the ACC range		–	–	2	dB
THR <sub>on</sub>	threshold colour killer ON		–23	–26	–29	dB
HYS <sub>off</sub>	hysteresis colour killer OFF	strong signal conditions; S/N ≥ 40 dB; note 6	–	+3	–	dB
		noisy input signals; note 6	–	+1	–	dB
ACL CIRCUIT						
	chrominance burst ratio at which the ACL starts to operate		2.3	–	2.7	
REFERENCE PART						
<i>Phase-locked loop; note 25</i>						
f <sub>CR</sub>	catching range		300	500	–	Hz
Δφ	phase shift for a ±400 Hz deviation of the oscillator frequency	note 6	–	–	2	deg
<i>Oscillator</i>						
TC <sub>osc</sub>	temperature coefficient of the oscillator frequency	note 6	–	2.0	2.5	Hz/K
Δf <sub>osc</sub>	oscillator frequency deviation with respect to the supply	note 6; V <sub>P</sub> = 8 V ±10%	–	–	250	Hz
R <sub>i</sub>	input resistance	pin 32; f = 3.58 MHz; note 2	–	1.5	–	kΩ
		pin 33; f = 4.43 MHz; note 2	–	1.0	–	kΩ
C <sub>i</sub>	input capacitance	pins 32 and 33; note 2	–	–	10	pF
HUE CONTROL						
HUE <sub>cr</sub>	hue control range	63 steps; see Fig.6	±35	±40	–	deg
ΔHUE	hue variation for ±10% V <sub>P</sub>	note 6	–	0	–	deg
ΔHUE/ΔT	hue variation with temperature	T <sub>amb</sub> = 0 to 70 °C; note 6	–	0	–	deg



## I<sup>2</sup>C-bus controlled PAL/NTSC TV processor

TDA8366

SYMBOL	PARAMETER	CONDITIONS	MIN.	TYP.	MAX.	UNIT
DEMODULATORS (PINS 27 AND 28)						
V <sub>28(p-p)</sub>	(R-Y) output signal amplitude (peak-to-peak value)	note 26	–	0.525	–	V
V <sub>27(p-p)</sub>	(B-Y) output signal amplitude (peak-to-peak value)	note 26	–	0.675	–	V
G	gain between both demodulators G(B-Y) and G(R-Y)		1.60	1.78	1.96	
ΔV	spread of signal amplitude ratio PAL/NTSC	note 6	–1	–	+1	dB
Z <sub>o</sub>	output impedance (R-Y)/(B-Y) output	note 6	–	500	–	Ω
B	bandwidth of demodulators	–3 dB; note 27	–	650	–	kHz
V <sub>27,28(p-p)</sub>	residual carrier output (peak-to-peak value)	f = f <sub>osc</sub> ; (R-Y) output			5	mV
		f = f <sub>osc</sub> ; (B-Y) output	–	–	5	mV
		f = 2f <sub>osc</sub> ; (R-Y) output			5	mV
		f = 2f <sub>osc</sub> ; (B-Y) output	–	–	5	mV
V <sub>28(p-p)</sub>	H/2 ripple at (R-Y) output (peak-to-peak value)		–	–	25	mV
ΔV <sub>o</sub> /ΔT	change of output signal amplitude with temperature	note 6	–	0.1	–	%/K
ΔV <sub>o</sub> /ΔV <sub>P</sub>	change of output signal amplitude with supply voltage	note 6	–	–	±0.1	dB
φ <sub>e</sub>	phase error in the demodulated signals		–	–	±5	deg
COLOUR DIFFERENCE MATRICES IN CONTROL CIRCUIT						
<i>PAL or (SECAM mode with TDA8395); (R-Y) and (B-Y) not affected</i>						
(G-Y)/(R-Y)	ratio of demodulated signals		–	–0.51 ±10%	–	
(G-Y)/(B-Y)	ratio of demodulated signals		–	–0.19 ±25%	–	
<i>NTSC mode; the colour-difference matrix results in the following signals (nominal hue setting)</i>						
(B-Y)	(B-Y) signal			(B-Y)		
(R-Y)	(R-Y) signal			1.39(R-Y) – 0.07(B-Y)		
(G-Y)	(G-Y) signal			–0.46(R-Y) – 0.15(B-Y)		

## I<sup>2</sup>C-bus controlled PAL/NTSC TV processor

TDA8366

SYMBOL	PARAMETER	CONDITIONS	MIN.	TYP.	MAX.	UNIT
REFERENCE SIGNAL OUTPUT FOR TDA8395 (PIN 31)						
f <sub>ref</sub>	reference frequency		–	4.43	–	MHz
V <sub>31(p-p)</sub>	output signal amplitude (peak-to-peak value)		0.2	0.25	0.3	V
V <sub>o</sub>	output level	PAL/NTSC identified	–	1.5	–	V
		no PAL/NTSC identified; SECAM (by TDA8395) identified	–	5.0	–	V
I <sub>31</sub>	required current to stop PAL/NTSC identification circuit during SECAM		150	–	–	μA
<b>Control part</b>						
SATURATION CONTROL; note 15						
SAT <sub>cr</sub>	saturation control range	63 steps; see Fig.7	52	–	–	dB
CONTRAST CONTROL; note 15						
CON <sub>cr</sub>	contrast control range	63 steps	–	20	–	dB
	tracking between the three channels over a control range of 10 dB	see Fig.8	–	–	0.5	dB
BRIGHTNESS CONTROL						
BRI <sub>cr</sub>	brightness control range	63 steps; see Fig.9	–	±0.7	–	V
RGB AMPLIFIERS (PINS 17, 18 AND 19)						
V <sub>17,18,19(p-p)</sub>	output signal amplitude (peak-to-peak value)	at nominal luminance input signal, nominal contrast and white-point adjustment; note 15	tbf	2.0	tbf	V
		at maximum white point setting	–	3.0	–	V
V <sub>BWmax(p-p)</sub>	maximum signal amplitude (black-to-white)	note 28	–	2.6	–	V
		at maximum white point setting	–	3.6	–	V
V <sub>RED(p-p)</sub>	output signal amplitude for the 'red' channel (peak-to-peak value)	at nominal settings for contrast and saturation control and no luminance signal to the input (R–Y, PAL)	tbf	2.1	tbf	V
V <sub>blank</sub>	blanking level at the RGB outputs		0.7	0.8	0.9	V
I <sub>bias</sub>	internal bias current of NPN emitter follower output transistor		–	1.5	–	mA
I <sub>o</sub>	available output current		–	5	–	mA
Z <sub>o</sub>	output impedance		–	150	–	Ω

**I<sup>2</sup>C-bus controlled PAL/NTSC TV  
processor**

TDA8366

SYMBOL	PARAMETER	CONDITIONS	MIN.	TYP.	MAX.	UNIT
RGB AMPLIFIERS (CONTINUED)						
CR <sub>bl</sub>	control range of the black-current stabilization	nominal brightness and white-point adjustment (with respect to the measuring pulse); V <sub>blk</sub> = 2.5 V	–	–	±1	V
V <sub>bl</sub>	black level shift with picture content	note 6	–	–	20	mV
V <sub>o</sub>	output voltage of the 4-L pulse after switch-on		–	4.2	–	V
Δbl/ΔT	variation of black level with temperature	note 6	–	1.0	–	mV/K
Δbl	relative variation in black level between the three channels during variations of supply voltage (±10%) saturation (50 dB) contrast (20 dB) brightness (±0.5 V) temperature (range 40 °C)	note 6  nominal controls nominal contrast nominal saturation nominal controls	– – – – –	– – – – –	tbf tbf tbf tbf tbf	mV mV mV mV mV
S/N	signal-to-noise ratio of the output signals	RGB input; note 29	60	–	–	dB
		CVBS input; note 29	50	–	–	dB
V <sub>res(p-p)</sub>	residual voltage at the RGB outputs (peak-to-peak value)	at f <sub>osc</sub>	–	–	15	mV
		at 2f <sub>osc</sub> plus higher harmonics in RGB outputs	–	–	15	mV
B	bandwidth of output signals	RGB input; at –3 dB	8	–	–	MHz
		CVBS input; at –3 dB; f <sub>osc</sub> = 3.58 MHz	–	2.8	–	MHz
		CVBS input; at –3 dB; f <sub>osc</sub> = 4.43 MHz	–	3.5	–	MHz
		S-VHS input; at –3 dB	5	–	–	MHz
WHITE-POINT ADJUSTMENT						
	I <sup>2</sup> C-bus setting for nominal gain	HEX code	–	20H	–	
G <sub>inc(max)</sub>	maximum increase of the gain	HEX code 3FH	40	50	60	%
G <sub>dec(max)</sub>	maximum decrease of the gain	HEX code 00H	40	50	60	%
BLACK-CURRENT STABILIZATION (PIN 16); note 30						
I <sub>bias</sub>	bias current for the picture tube cathode		–	10	–	μA
I <sub>leak</sub>	acceptable leakage current		–	100	–	μA
I <sub>scan(max)</sub>	maximum current during scan		–	0.3	–	mA

## I<sup>2</sup>C-bus controlled PAL/NTSC TV processor

TDA8366

SYMBOL	PARAMETER	CONDITIONS	MIN.	TYP.	MAX.	UNIT
BEAM CURRENT LIMITING (PIN 20); note 28						
V <sub>CR</sub>	contrast reduction starting voltage		–	4	–	V
V <sub>diffCR</sub>	voltage difference for full contrast reduction		–	2	–	V
V <sub>BR</sub>	brightness reduction starting voltage		–	3	–	V
V <sub>diffBR</sub>	voltage difference for full brightness reduction		–	2	–	V
V <sub>bias</sub>	internal bias voltage		–	4.5	–	V
I <sub>ch(int)</sub>	internal charge current		–	40	–	μA
I <sub>disch</sub>	discharge current due to 'peak-white limiting'		–	200	–	μA

### Notes

- On set AGC.
- This parameter is not tested during production and is just given as application information for the designer of the television receiver.
- Measured at 10 mV (RMS) top sync input signal.
- So called projected zero point, i.e. with switched demodulator.
- Measured in accordance with the test line given in Fig.10. For the differential phase test the peak white setting is reduced to 87%.
  - The differential gain is expressed as a percentage of the difference in peak amplitudes between the largest and smallest value relative to the subcarrier amplitude at blanking level.
  - The phase difference is defined as the difference in degrees between the largest and smallest phase angle.
- This parameter is not tested during production but is guaranteed by the design and qualified by means of matrix batches which are made in the pilot production period.
- This figure is valid for the complete video signal amplitude (peak white-to-black), see Fig.11.
- The test set-up and input conditions are given in Fig.12. The figures are measured with an input signal of 10 mV RMS.
- Measured with a source impedance of 75 Ω, where:
 
$$S/N = 20 \log \frac{V_O \text{ (black-to-white)}}{\sqrt{m_{(rms)}} (B = 5 \text{ MHz})}$$
- To obtain a good noise immunity of the AGC circuit the AGC detector is gated during the sync pulse. This gating is switched-off during the vertical retrace to avoid disturbances of the signal amplitude due to phase errors of the incoming video signal which are caused by the head-switching of VCRs.

## I<sup>2</sup>C-bus controlled PAL/NTSC TV processor

TDA8366

11. The AFC slope is directly related to the Q-factor of the demodulator tuned circuit. The given AFC steepness is obtained with a Q-factor of 60. The AFC off-set is tested with a double sideband input signal and with the reference tuned circuit tuned to minimum AGC voltage (optimum tuning for the demodulator).

The tuning information is supplied to the tuning system via the I<sup>2</sup>C-bus. Two bits have been reserved for this function. The first bit indicates whether the tuning is within the given window. The second bit indicates the direction of the tuning. Bit indications:

- a) AFA = 1; tuning inside window.
- b) AFA = 0; tuning outside window.
- c) AFB = 1; tuning too high.
- d) AFB = 0; tuning too low.

To improve the speed of search tuning systems the AFC window can be increased to about 240 kHz. The width of the window can be set by means of the AFW bit in subaddress 03.

12. Signal with negative-going sync. Amplitude includes sync pulse amplitude.
13. This parameter is measured at nominal settings of the various controls.
14. Indicated is a signal for a colour bar with 75% saturation (chroma : burst ratio = 2.2 : 1).
15. Nominal contrast is specified with the DAC in position 20H. Nominal saturation as maximum -10 dB. In the nominal brightness setting the black level at the outputs is identical to the level of the black-current measuring pulses.
16. The -3 dB bandwidth of the circuit can be calculated by means of the following equation:

$$f_{-3\text{ dB}} = f_{\text{osc}} \left( 1 - \frac{1}{2Q} \right)$$

17. Valid for a signal amplitude on the Y-input of 0.7 V black-to-white (100 IRE) with a rise time (10% to 90%) of 70 ns and the video switch in the Y/C mode. During production the peaking function is not tested by measuring the overshoots but by measuring the frequency response of the Y output.
18. The slicing level is independent of sync pulse amplitude. The given percentage is the distance between the slicing level and the black level (back porch).
19. To obtain a good performance for both weak signal and VCR playback the time constant of the first control loop is switched depending on the input signal condition and the condition of the I<sup>2</sup>C-bus. Therefore the circuit contains a noise detector and the time constant is switched to 'slow' when too much noise is present in the signal. In the 'fast' mode during the vertical retrace time the phase detector current is increased 50% so that phase errors due to head-switching of the VCR are corrected as soon as possible. Switching between the two modes can be automatically or overruled by the I<sup>2</sup>C-bus.

The circuit contains a video identification circuit which is independent of first loop. This identification circuit can be used to close or open the first control loop when a video signal is present or not present on the input. This enables a stable On Screen Display (OSD) when just noise is present at the input. The coupling of the video identification circuit with the first loop can be defeated via the I<sup>2</sup>C-bus.

When the horizontal PLL is set to the 'slow' mode (via I<sup>2</sup>C-bus bits FOA and FOB) or during weak signal conditions in the 'automatic' mode the phase detector is gated to obtain a good noise immunity. The width of the gating pulse is 5.7 μs.

The output current of the phase detector in the various conditions are shown in Table 42.

20. During the start-up period of the oscillator the duty factor of the output pulse rises gradually from 0% to 50% (time approximately 100 lines).
21. The start-up frequency depends on the SFM bit in the I<sup>2</sup>C-bus protocol. When SFM = 0 the frequency starts at a high (non calibrated) value. When SFM = 1 the output signal will only be available after calibration.

## I<sup>2</sup>C-bus controlled PAL/NTSC TV processor

TDA8366

22. The timing pulses for the vertical ramp generator are obtained from the horizontal oscillator via a divider circuit. This divider circuit has 3 modes of operation:

a) Search mode 'large window'.

This mode is switched on when the circuit is not synchronized or when a non-standard signal (number of lines per frame in the 50 Hz mode is between 311 and 314 and in the 60 Hz mode between 261 and 264). In the search mode the divider can be triggered between line 244 and line 361 (approximately 45 to 64.5 Hz).

b) Standard mode 'narrow window'.

This mode is switched on when more than 15 succeeding vertical sync pulses are detected in the narrow window. When the circuit is in the standard mode and a vertical sync pulse is missing the retrace of the vertical ramp generator is started at the end of the window. Consequently, the disturbance of the picture is very small. The circuit will switch back to the search window when, for 6 successive vertical periods, no sync pulses are found within the window.

c) Standard TV-norm (divider ratio 525 (60 Hz) or 625 (50 Hz)).

When the system is switched to the narrow window it is checked whether the incoming vertical sync pulses are in accordance with the TV-norm. When 15 standard TV-norm pulses are counted the divider system is switched to the standard divider ratio mode. In this mode the divider is always reset at the standard value even if the vertical sync pulse is missing.

When 3 vertical sync pulses are missed the system switches back to the narrow window and when also in this window no sync pulses are found (condition 3 missing pulses) the system switches over to the search window.

The vertical divider needs some waiting time during channel-switching of the tuner. When a fast reaction of the divider is required during channel-switching the system can be forced to the search window by means of the NCIN bit in subaddress 08.

23. Conditions: frequency is 50 Hz; normal mode; VS = 1F.

24. At a chrominance input voltage of 660 mV (p-p) (colour bar with 75% saturation i.e. burst signal amplitude 300 mV (p-p)) the dynamic range of the ACC is +6 and -20 dB.

25. All frequency variations are referenced to 3.58 or 4.43 MHz carrier frequency.

All oscillator specifications are measured with the Philips crystal series 9922 520.

If the spurious response of the 4.43 MHz crystal is lower than -1 dB with respect to the fundamental frequency for a damping resistance of 1 k $\Omega$ , oscillation at the fundamental frequency is guaranteed.

The spurious response of the 3.58 MHz crystal must be lower than -1 dB with respect to the fundamental frequency for a damping resistance of 1.5 k $\Omega$ .

The catching and detuning range are measured for nominal crystal parameters. These are:

a) Load resonance frequency  $f_0 = 4.433619$  or  $3.579545$  MHz;  $C_L = 20$  pF.

b) Motional capacitance  $C_1 = 20.6$  fF (4.43 MHz crystal) or  $14.7$  fF (3.58 MHz crystal).

c) Parallel capacitance  $C_0 = 5.5$  pF (4.43 MHz crystal) or  $4.5$  pF (3.58 MHz crystal).

The actual load capacitance in the application should be  $C_L = 18$  pF to account for parasitic capacitances on and off chip.

Philips Components has developed a special crystal which is tuned to the correct frequency in an application without series capacitance (code number 9922 520 0038X; see Table 43). This has the advantage that the tuning (catching) range is increased with approximately 50% without negative effects on spurious responses. When the catching range of 300 Hz is considered too low this special crystal is a suitable alternative.

The free-running frequency of the oscillator can be checked by opening the colour PLL via the I<sup>2</sup>C-bus. In that condition the colour killer is not active so that the frequency off-set is visible on the screen. When two crystals are connected to the IC the circuit must be forced to one of the crystals during this test to prevent the oscillator switching continuously between the two frequencies.

## I<sup>2</sup>C-bus controlled PAL/NTSC TV processor

TDA8366

26. The (R-Y) and (B-Y) signals are demodulated with a phase difference of the reference carrier of 90° and a gain ratio  $\frac{(B-Y)}{(R-Y)} = 1.78$ . The matrixing to the required signals is achieved in the control part.
27. This parameter indicates the bandwidth of the complete chrominance circuit including the chrominance bandpass filter. The bandwidth of the low-pass filter of the demodulator is approximately 1 MHz.
28. At nominal setting of the gain control. When this amplitude is exceeded the peak-white limiting circuit will reduce the contrast. The control voltage is generated via the external capacitor connected to the beam-current limiting input.
29. Signal-to-noise ratio (S/N) is specified as peak-to-peak signal with respect to RMS noise (bandwidth 5 MHz).
30. This is a current input. The indicated value of the nominal bias current is obtained at the nominal setting of the gain (white point) control. The actual value of the bias current depends on the gain control setting of each channel. As a result the 'black-current' of each gun is adapted to the white point setting so that the back-ground colour will follow the white point adjustment.

**Table 42** Output current of the phase detector in the various conditions

I <sup>2</sup> C-BUS COMMANDS				IC CONDITIONS			φ-1 CURRENT/MODE			
VID	POC	FOA	FOB	IDENT	COIN	NOISE	SCAN	V-RETR	GATING	MODE
-	0	0	0	yes	yes	yes	30	30	yes	auto
-	0	0	0	yes	no	-	180	270	no	auto
-	0	0	1	yes	yes	-	30	30	yes	slow
-	0	0	1	yes	no	-	180	270	no	slow
-	0	1	-	yes	-	-	180	270	no	fast
0	0	-	-	no	-	-	6	6	no	OSD
-	1	-	-	-	-	-	-	-	-	off

**Table 43** Code numbers for special crystals

SYSTEM	FREQUENCY (MHz)	CODE NUMBER
PAL-N	3.582056	9922 520 00381
NTSC-M	3.579545	9922 520 00382
PAL-M	3.575611	9922 520 00383
PAL-B/G	4.433619	9922 520 00384

I<sup>2</sup>C-bus controlled PAL/NTSC TV processor

TDA8366

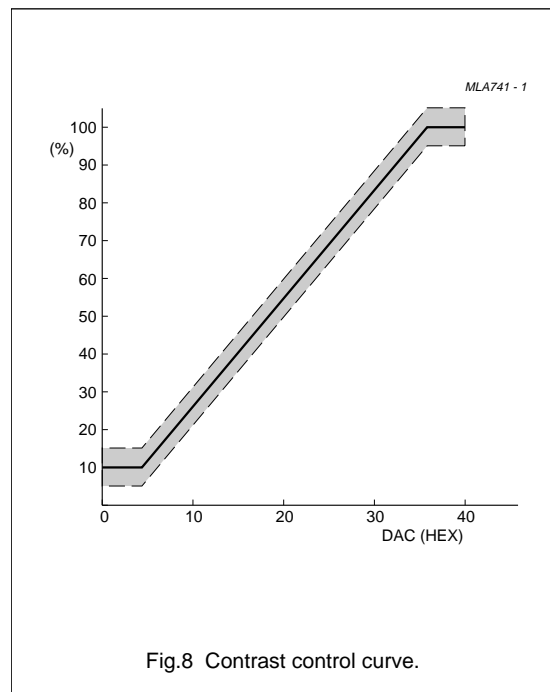
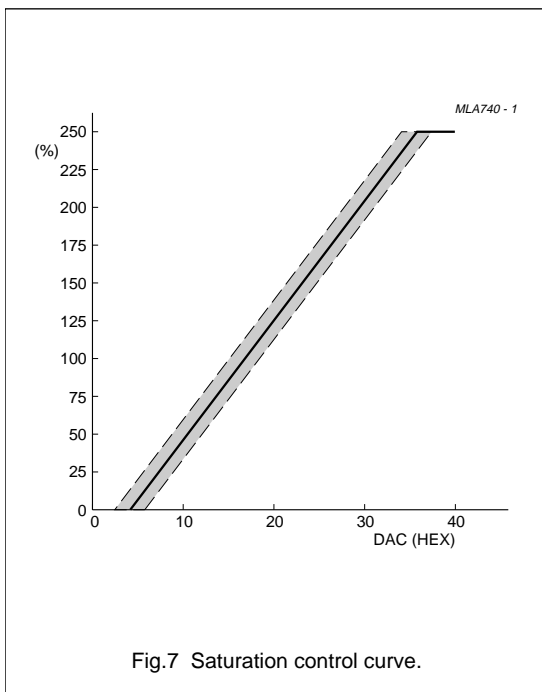
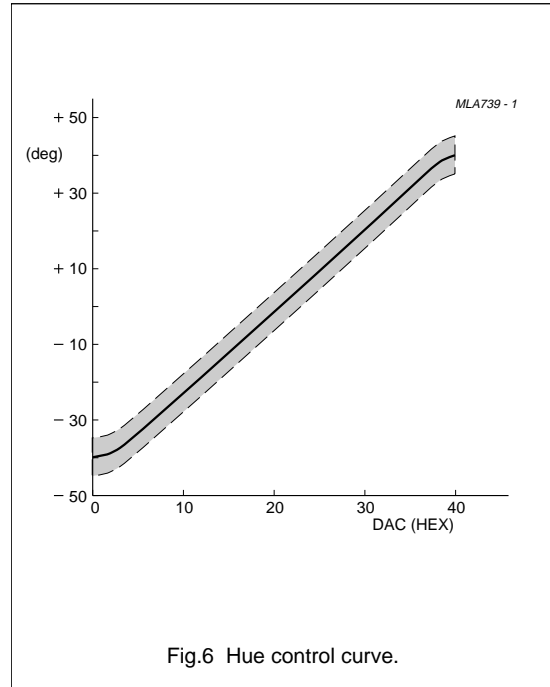
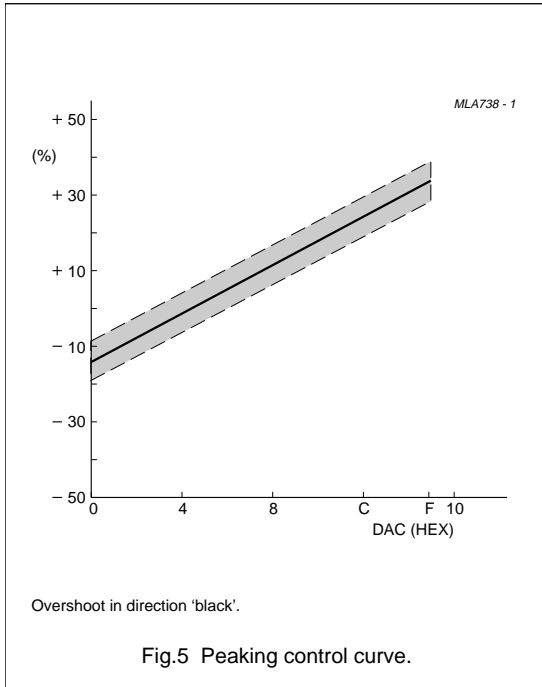



I<sup>2</sup>C-bus controlled PAL/NTSC TV processor

TDA8366

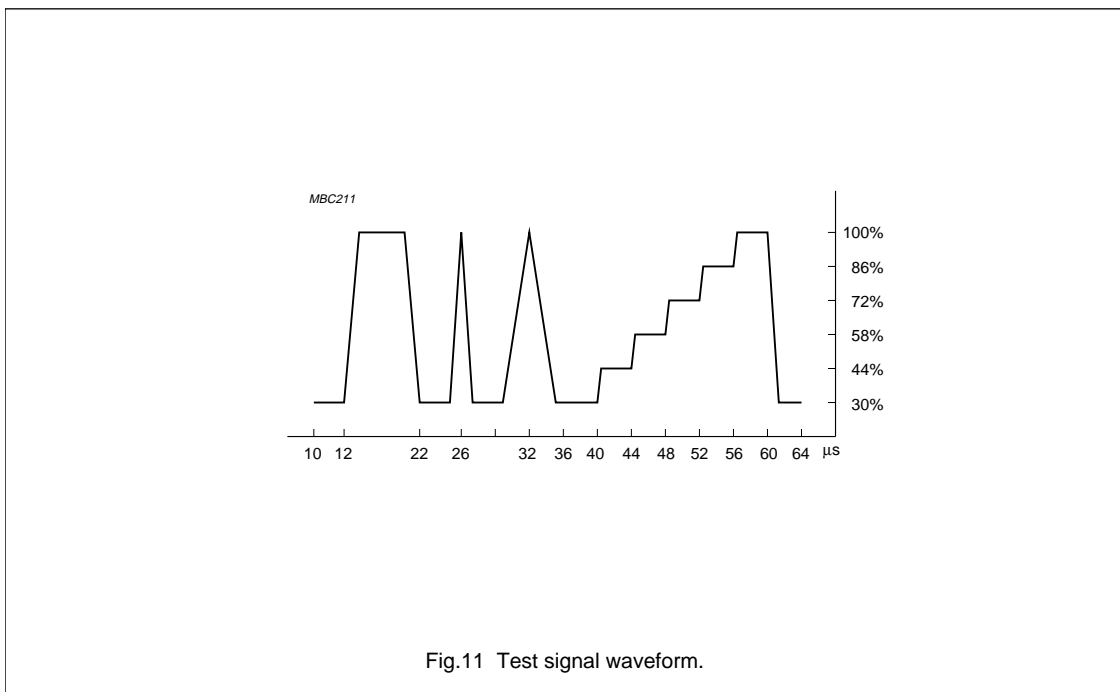
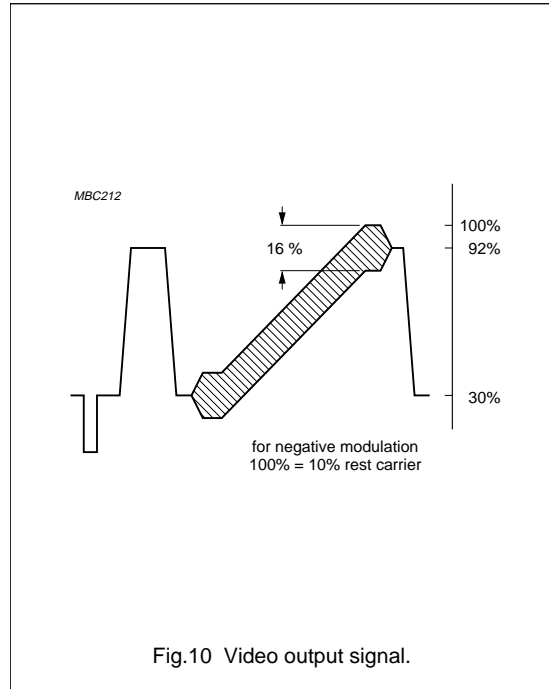
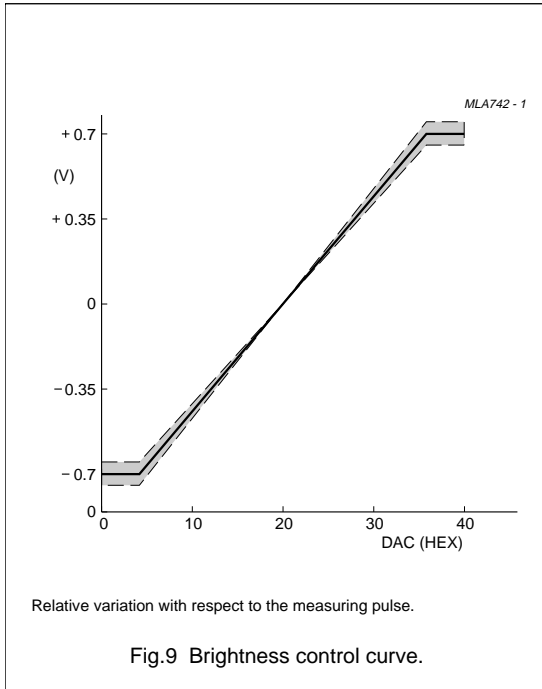

I<sup>2</sup>C-bus controlled PAL/NTSC TV processor

TDA8366

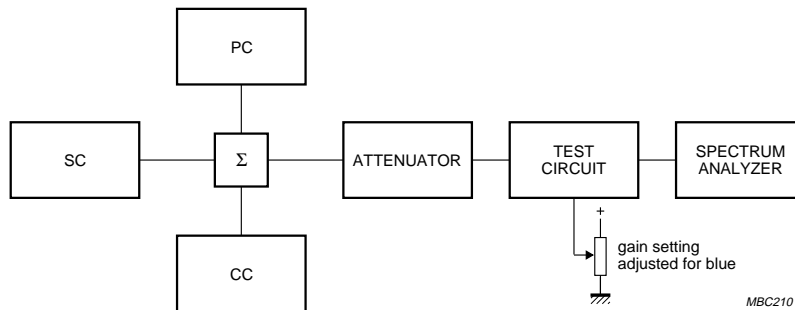
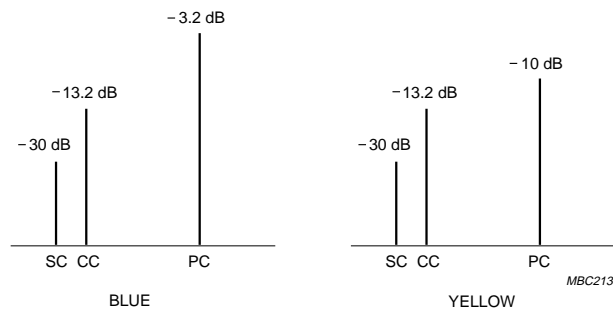

Input signal conditions: SC = sound carrier; CC = colour carrier; PC = picture carrier.  
All amplitudes with respect to top sync level.

$$\text{Value at 0.92 or 1.1 MHz} = 20 \log \frac{V_O \text{ at 3.58 or 4.4 MHz}}{V_O \text{ at 0.92 or 1.1 MHz}} + 3.6 \text{ dB}$$

$$\text{Value at 2.66 or 3.3 MHz} = 20 \log \frac{V_O \text{ at 3.58 or 4.4 MHz}}{V_O \text{ at 2.66 or 3.3 MHz}}$$

Fig.12 Test set-up intermodulation.

I<sup>2</sup>C-bus controlled PAL/NTSC TV processor

TDA8366

TEST AND APPLICATION INFORMATION

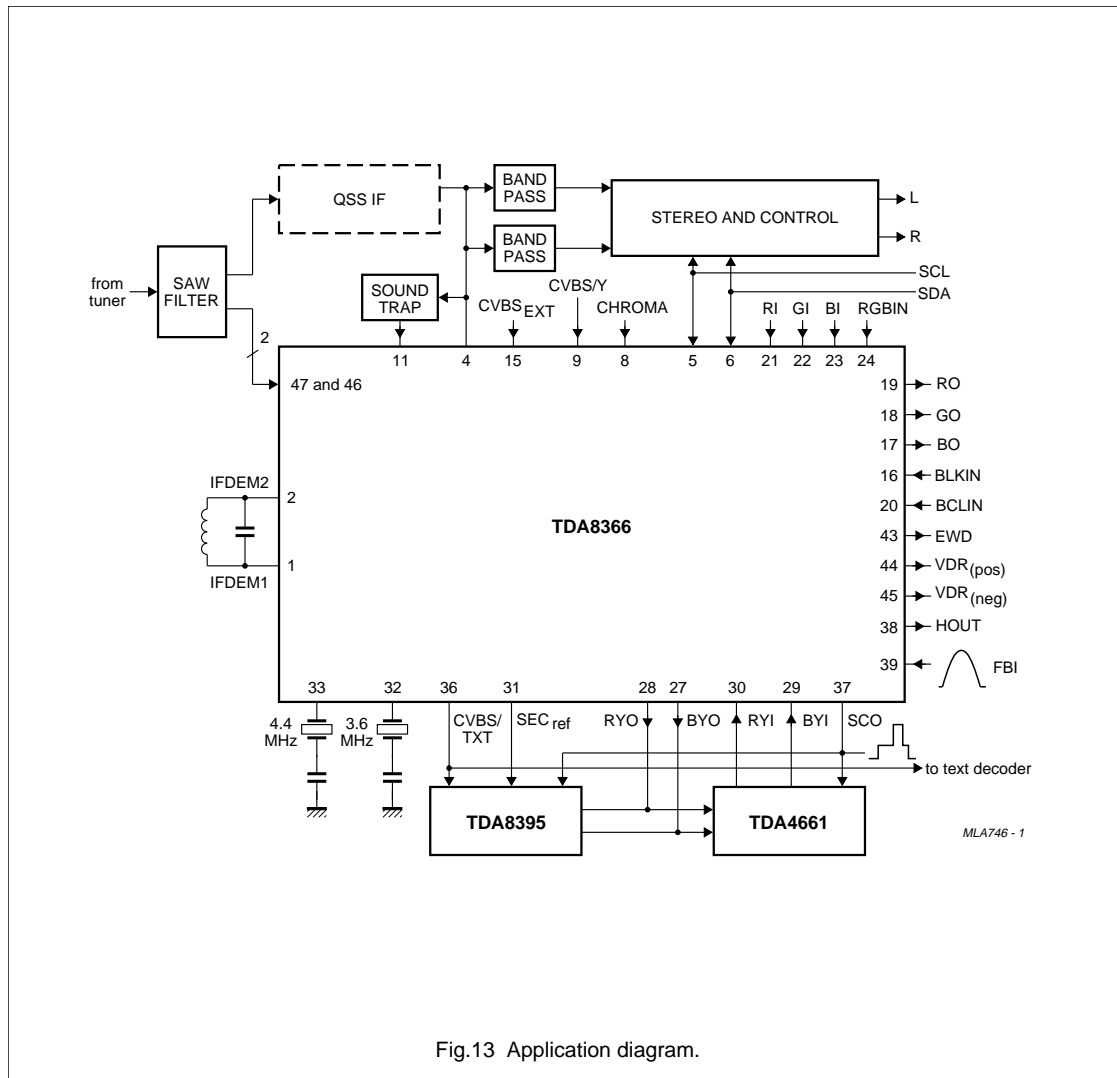

Fig.13 Application diagram.

**East-West output stage**

In order to obtain correct tracking of the vertical and horizontal EHT-correction, the EW output stage should be dimensioned as illustrated in Fig.14.

Resistor R<sub>EW</sub> determines the gain of the EW output stage. Resistor R<sub>c</sub> determines the reference current for both the vertical sawtooth generator and the geometry processor.

The preferred value of R<sub>c</sub> is 39 kΩ which results in a reference current of 100 μA (V<sub>ref</sub> = 3.9 V).

The value of R<sub>EW</sub> must be:

$$R_{EW} = R_c \times \frac{V_{scan}}{18 \times V_{ref}}$$

Example: With V<sub>ref</sub> = 3.9 V; R<sub>c</sub> = 39 kΩ and V<sub>scan</sub> = 120 V then R<sub>EW</sub> = 68 kΩ.

I<sup>2</sup>C-bus controlled PAL/NTSC TV processor

TDA8366

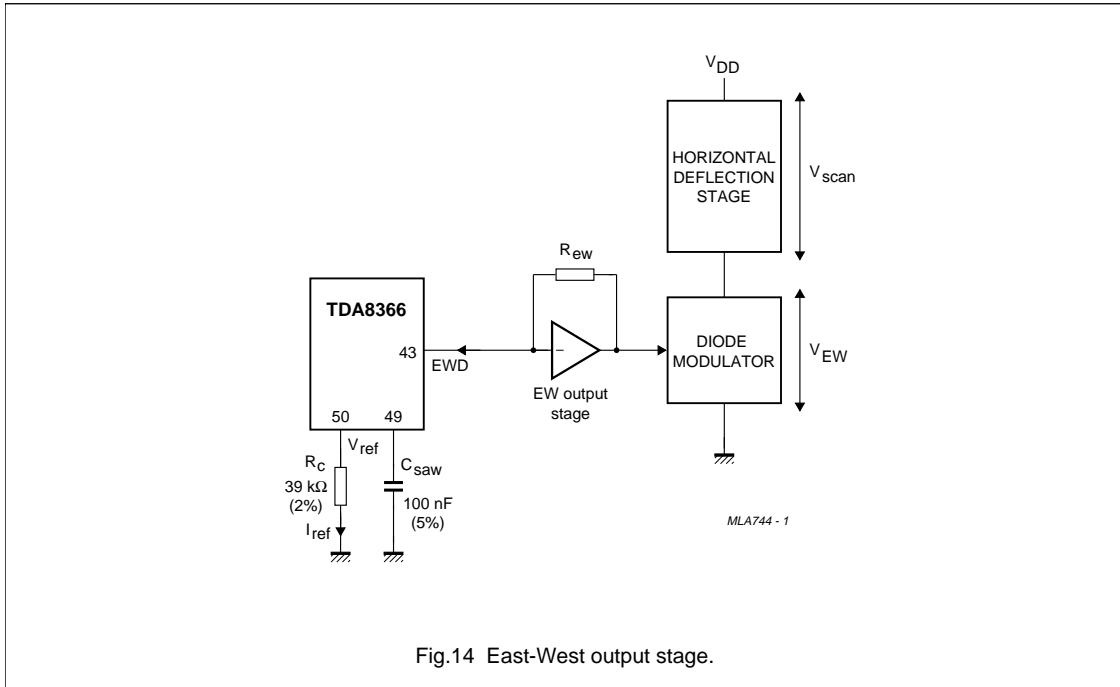

Fig.14 East-West output stage.

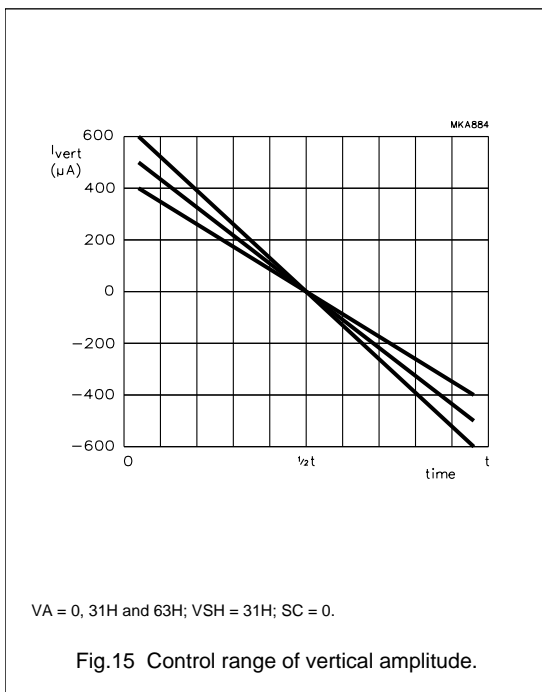

Fig.15 Control range of vertical amplitude.

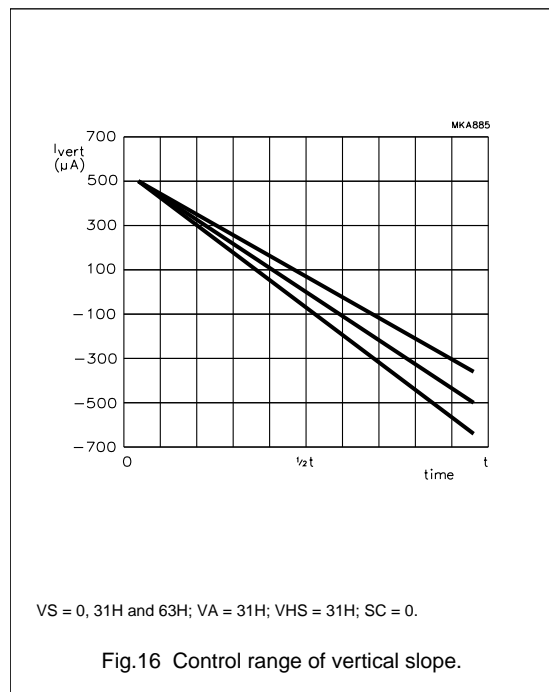
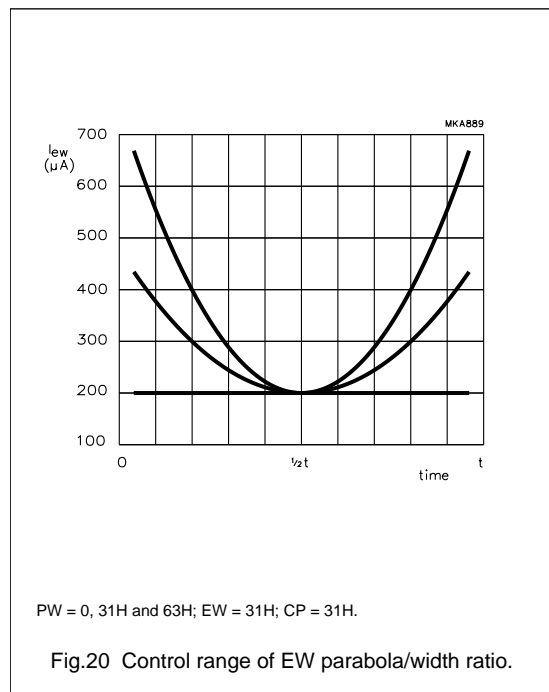
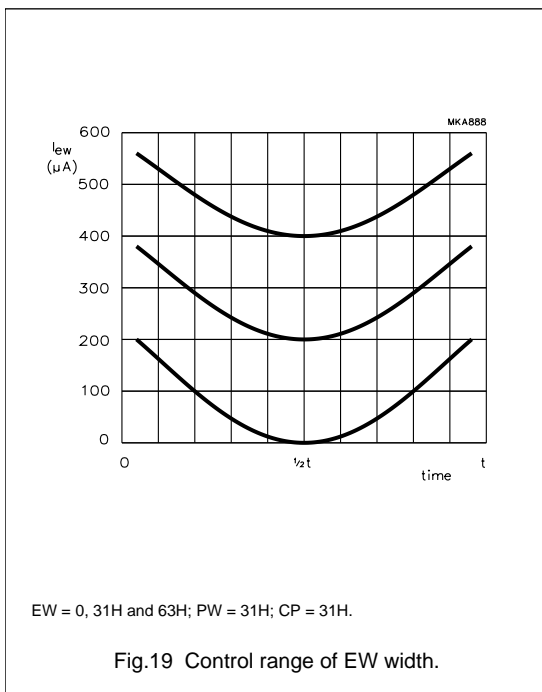
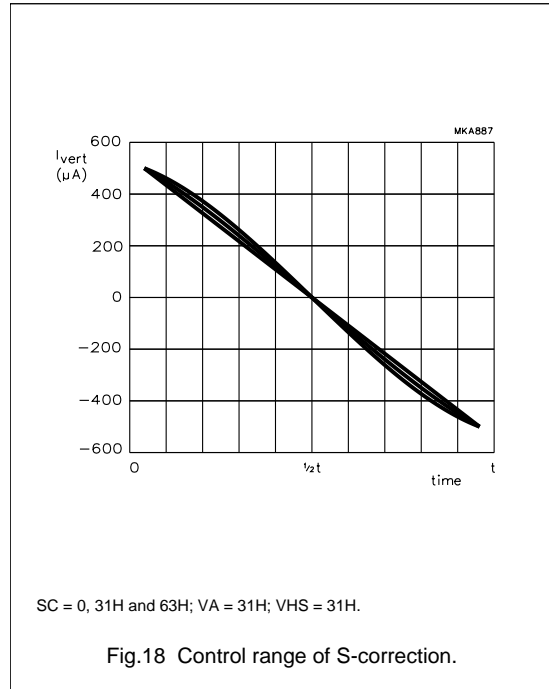
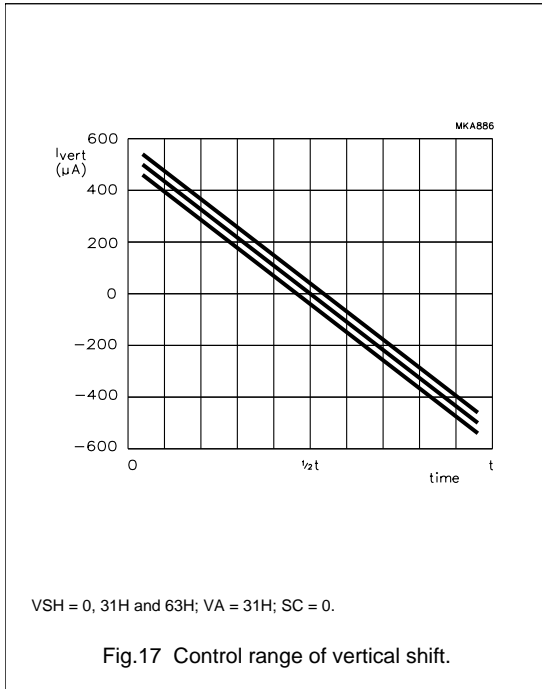

Fig.16 Control range of vertical slope.

I<sup>2</sup>C-bus controlled PAL/NTSC TV processor

TDA8366



I<sup>2</sup>C-bus controlled PAL/NTSC TV processor

TDA8366

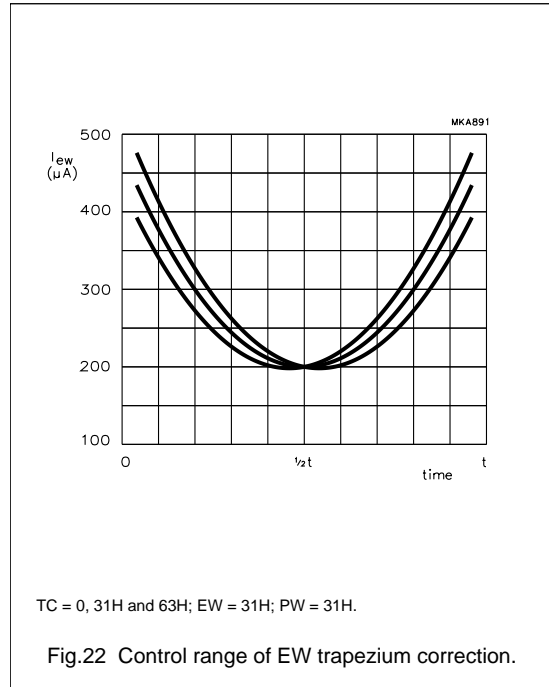
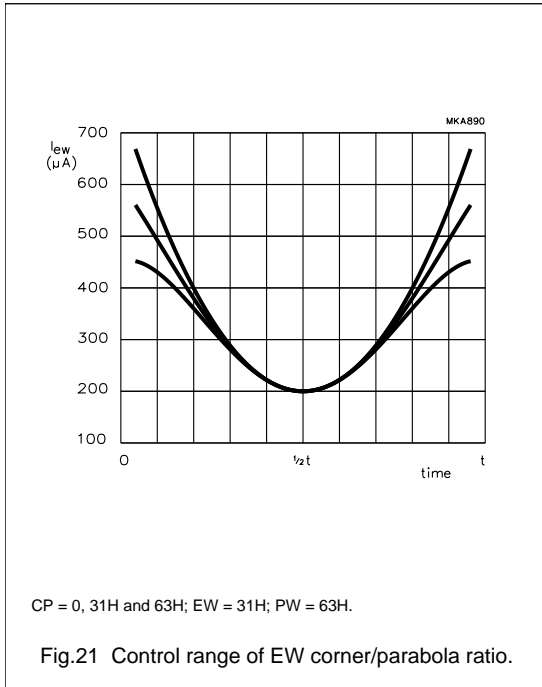

## I<sup>2</sup>C-bus controlled PAL/NTSC TV processor

TDA8366

### Adjustment of geometry control parameters

The deflection processor of the TDA8366 offers nine control parameters for picture alignment:

- Vertical picture alignment
  - S-correction
  - vertical amplitude
  - vertical slope
  - vertical shift
- Horizontal picture alignment
  - horizontal shift
  - EW width
  - EW parabola/width
  - EW corner/parabola
  - EW trapezium correction.

It is important to notice that the TDA8366 is designed for use with a DC-coupled vertical deflection stage. This is the reason why a vertical linearity alignment is not necessary (and therefore not available).

For a particular combination of picture tube type, vertical output stage and EW output stage it is determined which are the required values for the settings of S-correction, EW parabola/width ratio and EW corner/parabola ratio. These parameters can be preset via the I<sup>2</sup>C-bus, and do not need any additional adjustment. The rest of the parameters are preset with the mid-value of their control range (i.e. 1FH), or with the values obtained by previous TV-set adjustments.

The vertical shift control is meant for compensation of off-sets in the external vertical output stage or in the picture tube. It can be shown that without compensation these off-sets will result in a certain linearity error, especially with picture tubes that need large S-correction. The total linearity error is in first order approximation proportional to the value of the off-set, and to the square of the S-correction needed. The necessity to use the vertical shift alignment depends on the expected off-sets in vertical output stage and picture tube, on the required value of the S-correction, and on the demands upon vertical linearity.

For adjustment of the vertical shift and vertical slope independent of each other, a special service blanking mode can be entered by setting the SBL bit HIGH. In this mode the RGB-outputs are blanked during the second half of the picture. There are 2 different methods for alignment of the picture in vertical direction. Both methods make use of the service blanking mode.

The first method is recommended for picture tubes that have a marking for the middle of the screen. With the vertical shift control the last line of the visible picture is positioned exactly in the middle of the screen. After this adjustment the vertical shift should not be changed. The top of the picture is placed by adjustment of the vertical amplitude, and the bottom by adjustment of the vertical slope.

The second method is recommended for picture tubes that have no marking for the middle of the screen. For this method a video signal is required in which the middle of the picture is indicated (e.g. the white line in the circle test pattern). With the vertical slope control the beginning of the blanking is positioned exactly on the middle of the picture. Then the top and bottom of the picture are placed symmetrical with respect to the middle of the screen by adjustment of the vertical amplitude and vertical shift. After this adjustment the vertical shift has the right setting and should not be changed.

If the vertical shift alignment is not required VSH should be set to its mid-value (i.e. VSH = 1F). Then the top of the picture is placed by adjustment of the vertical amplitude and the bottom by adjustment of the vertical slope. After the vertical picture alignment the picture is positioned in the horizontal direction by adjustment of the EW width and the horizontal shift. Finally (if necessary) the left- and right-hand sides of the picture are aligned in parallel by adjusting the EW trapezium control.

After adjustment of the picture for normal vertical deflection as described, no additional adjustment is necessary for the compress and expand mode. If required a small correction of the picture height can be made by adjusting the vertical slope. This will not effect the linearity.