

## AUDIO POWER AMPLIFIER

The TA7368P and TA7368F are suitable for the audio power amplifier of portable cassette tape recorder and radio.

### FEATURES

- Very few external parts (Only three capacitors)
- Low quiescent current :  $I_{CCQ} = 6.6\text{mA}$  (Typ.) ( $V_{CC} = 6\text{V}$ )
- Output Power  
 TA7368P  
 :  $P_{out} = 720\text{mW}$  (Typ.) ( $V_{CC} = 6\text{V}$ ,  $R_L = 4\Omega$ , THD = 10%)  
 TA7368P/F  
 :  $P_{out} = 450\text{mW}$  (Typ.) ( $V_{CC} = 6\text{V}$ ,  $R_L = 8\Omega$ , THD = 10%)
- Voltage gain :  $G_V = 40\text{dB}$  (Typ.)
- Operating supply voltage range :  $V_{CC} = 2\sim 10\text{V}$  ( $T_a = 25^\circ\text{C}$ )

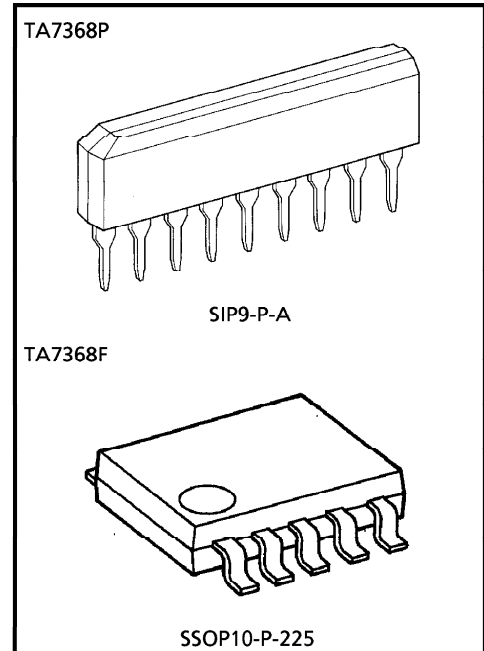

Weight SIP9-P-A : 0.92g (Typ.)  
 SSOP10-P-225 : 0.09g (Typ.)

### BLOCK DIAGRAM

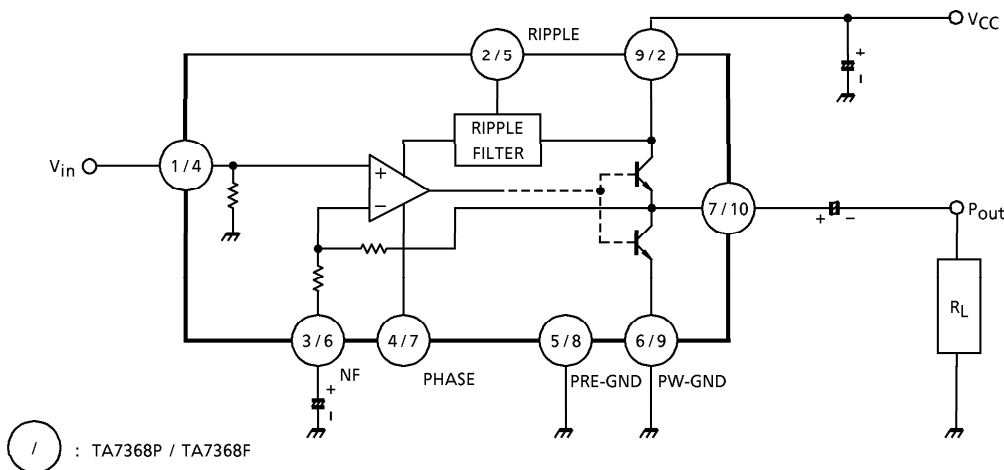

© The information contained herein is presented only as a guide for the applications of our products. No responsibility is assumed by TOSHIBA CORPORATION for any infringements of intellectual property or other rights of the third parties which may result from its use. No license is granted by implication of otherwise under any intellectual property or other rights of TOSHIBA CORPORATION or others.

© These TOSHIBA products are intended for use in general commercial applications (office equipment, communication equipment, measuring equipment, domestic appliances, etc.). please make sure that you consult with us before you use these TOSHIBA products in equipment which requires extraordinarily high quality and/or reliability, and in equipment which may involve life threatening or critical application, including but not limited to such uses as atomic energy control, airplane or spaceship instrumentation, traffic signals, medical instrumentation, combustion control, all types of safety devices, etc. TOSHIBA cannot accept and hereby disclaims liability for any damage which may occur in case the TOSHIBA products are used in such equipment or applications without prior consultation with TOSHIBA.

**PRECAUTION FOR USE AND APPLICATION**

**1. Input stage**

The input stage of power amplifier (Equivalent circuit) is comprised of a PNP differential pair (Q<sub>2</sub> and Q<sub>3</sub>) preceded by a PNP emitter follower (Q<sub>1</sub>) which allows DC referencing of the source signal to ground. This eliminated the need for an input coupling capacitor. However, in case the brush noise of volume becomes a problem, provide serially a coupling capacitor to the input side.

**2. Adjustment of voltage gain**

The voltage gain is fixed at  $G_V \approx 40\text{dB}$  by the resistors (R<sub>4</sub> and R<sub>5</sub>) in IC, however, its reduction is possible through adding R<sub>f</sub> as shown in Figure 2. In this case, the voltage gain is obtained by the following equation.

$$G_V = 20 \log \frac{R_5 + R_4 + R_f}{R_4 + R_f}$$

It is recommended to use this IC with the voltage gain of  $G_V = 28\text{dB}$  or over.

**3. Ripple rejection ratio**

Adding C<sub>RIP</sub> to ripple terminal 2 as shown in Figure 3, the ripple rejection ratio is improved from  $-25\text{dB Typ.}$  to  $-45\text{dB Typ.}$

**4. Power dissipation**

Care should be taken to use this IC below maximum power dissipation. Because it may over maximum rating depending on operating condition.

- TA7368P  $P_D = 900\text{mW}$  ( $T_a = 25^\circ\text{C}$ )
- TA7368F  $P_D = 400\text{mW}$  ( $T_a = 25^\circ\text{C}$ )

**5. Phase-compensation**

Small temperature coefficient and excellent frequency characteristic is needed by capacitors below.

- Oscillation preventing capacitors for power amplifier output
- Bypass capacitor for ripple filter
- Capacitor between V<sub>CC</sub> and GND

⊘ : TA7368P / TA7368F

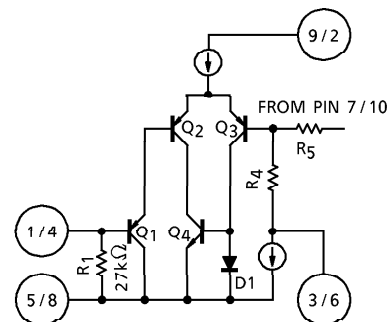

Fig.1

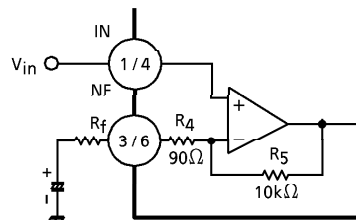

Fig.2

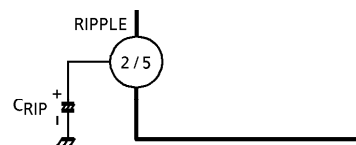

Fig.3

**MAXIMUM RATINGS** (Ta = 25°C)

CHARACTERISTIC	SYMBOL	RATING	UNIT
Supply Voltage	V <sub>CC</sub>	14	V
Power Dissipation	TA7368P	900	mW
	TA7368F	400	
Operating Temperature	T <sub>opr</sub>	-25~75	°C
Storage Temperature	T <sub>stg</sub>	-55~150	°C

(Note) Derated above Ta = 25°C in the proportion of 7.2mW/°C for TA7368P and of 3.2mW/°C for TA7368F.

**ELECTRICAL CHARACTERISTICS FOR TA7368P**

(Unless otherwise specified, V<sub>CC</sub> = 6V, f = 1kHz, R<sub>g</sub> = 600Ω, R<sub>L</sub> = 4Ω, Ta = 25°C)

CHARACTERISTIC	SYMBOL	TEST CIRCUIT	TEST CONDITION	MIN.	TYP.	MAX.	UNIT
Quiescent Current	I <sub>CCQ</sub>	—	V <sub>CC</sub> = 3V, V <sub>in</sub> = 0	—	5.5	—	mA
			V <sub>CC</sub> = 6V, V <sub>in</sub> = 0	—	6.6	15	
			V <sub>CC</sub> = 9V, V <sub>in</sub> = 0	—	7.5	18	
Output Power	P <sub>out</sub>	—	V <sub>CC</sub> = 3V, R <sub>L</sub> = 4Ω, THD = 10%	—	120	—	mW
			V <sub>CC</sub> = 6V, R <sub>L</sub> = 4Ω, THD = 10%	500	720	—	
			V <sub>CC</sub> = 6V, R <sub>L</sub> = 8Ω, THD = 10%	300	450	—	
			V <sub>CC</sub> = 9V, R <sub>L</sub> = 8Ω, THD = 10%	800	1100	—	
			V <sub>CC</sub> = 9V, R <sub>L</sub> = 16Ω, THD = 10%	450	610	—	
Total Harmonic Distortion	THD	—	P <sub>out</sub> = 100mW	—	0.3	1.0	%
Voltage Gain	G <sub>V</sub>	—	V <sub>in</sub> = 0.5mV <sub>rms</sub>	37	40	43	dB
Output Noise Voltage	V <sub>no</sub>	—	R <sub>g</sub> = 10kΩ, BPF = 20Hz~20kHz	—	0.2	0.5	mV <sub>rms</sub>
Ripple Rejection Ratio	RR	—	f <sub>r</sub> = 100Hz, V <sub>r</sub> = 0.3V <sub>rms</sub> Without C <sub>RIP</sub>	—	25	—	dB
Input Resistance	R <sub>IN</sub>	—	—	—	27	—	kΩ

**TERMINAL VOLTAGE FOR TA7368P**

Typical terminal voltage at no signal with test circuit. (V<sub>CC</sub> = 6V, Ta = 25°C)

[Unit : V]

Terminal No.	1	2	3	4	5	6	7	8	9
DC Voltage (V)	0	2.40	0.62	0.64	0	0	2.61	NC	6.0

**ELECTRICAL CHARACTERISTICS FOR TA7368F**

(Unless otherwise specified,  $V_{CC} = 6V$ ,  $f = 1kHz$ ,  $R_g = 600\Omega$ ,  $R_L = 8\Omega$ ,  $T_a = 25^\circ C$ )

CHARACTERISTIC	SYMBOL	TEST CIR-CUIT	TEST CONDITION	MIN.	TYP.	MAX.	UNIT
Quiescent Current	$I_{CCQ}$	—	$V_{CC} = 3V, V_{in} = 0$	—	5.5	—	mA
			$V_{CC} = 6V, V_{in} = 0$	—	6.6	15	
			$V_{CC} = 9V, V_{in} = 0$	—	7.5	18	
Output Power	$P_{out}$	—	$V_{CC} = 3V, R_L = 4\Omega, THD = 10\%$	—	120	—	mW
			$V_{CC} = 6V, R_L = 8\Omega, THD = 10\%$	300	450	—	
			$V_{CC} = 9V, R_L = 16\Omega, THD = 10\%$	450	610	—	
Total Harmonic Distortion	THD	—	$P_{out} = 100mW$	—	0.3	1.0	%
Voltage Gain	$G_V$	—	$V_{in} = 0.5mV_{rms}$	37	40	43	dB
Output Noise Voltage	$V_{no}$	—	$R_g = 10k\Omega, BPF = 20Hz \sim 20kHz$	—	0.2	0.5	$mV_{rms}$
Ripple Rejection Ratio	RR	—	$f_r = 100Hz, V_r = 0.3V_{rms}$ , Without $C_{RIP}$	—	25	—	dB
Input Resistance	$R_{IN}$	—	—	—	27	—	$k\Omega$

**TERMINAL VOLTAGE FOR TA7368F**

Typical terminal voltage at no signal with test circuit. ( $V_{CC} = 6V$ ,  $T_a = 25^\circ C$ )

[Unit : V]

Terminal No.	1	2	3	4	5	6	7	8	9	10
DC Voltage (V)	NC	6.0	NC	0	2.40	0.62	0.64	0	0	2.61

**TEST CIRCUIT**

**TA7368P**

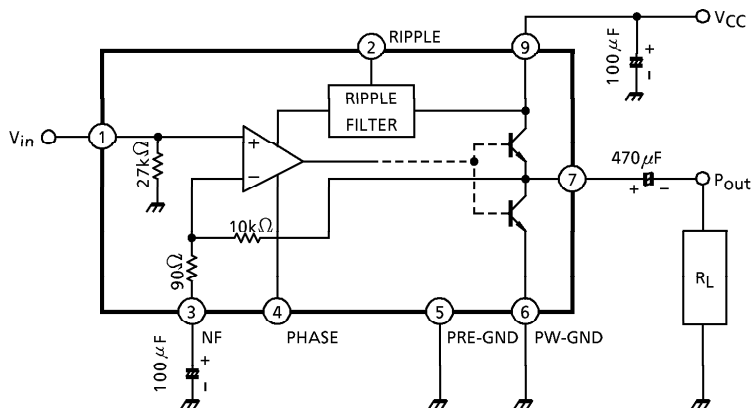

※ Pin⑧ : Non-connection

**TA7368F**

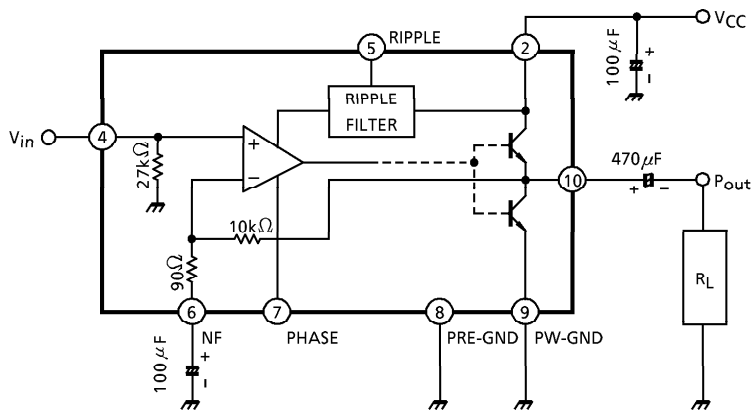

※ Pin①, ③ : Non-connection

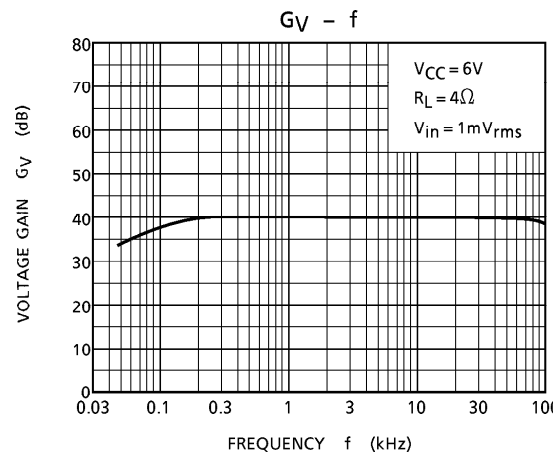
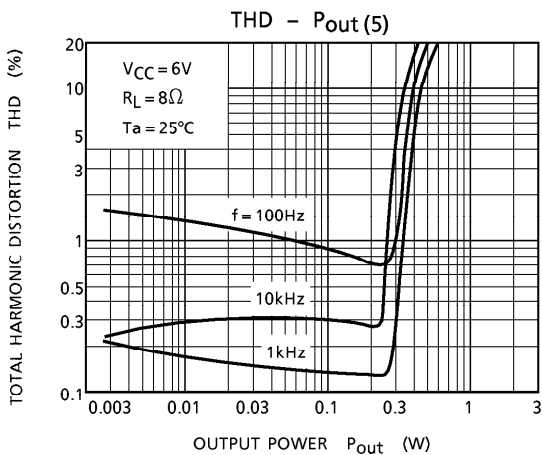
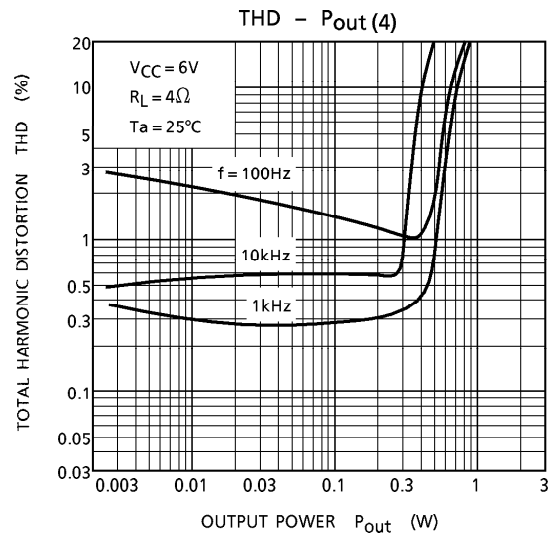
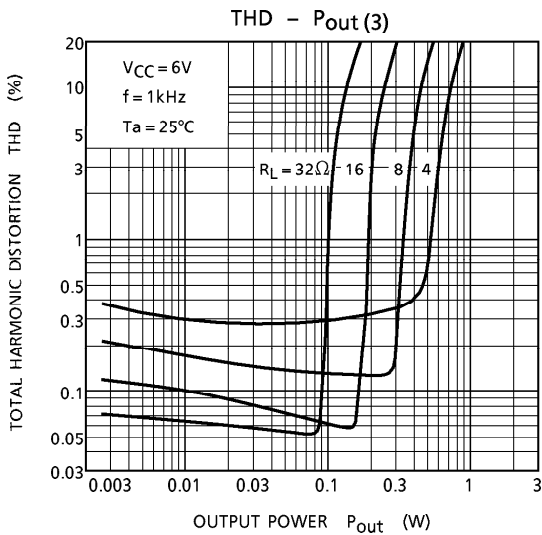
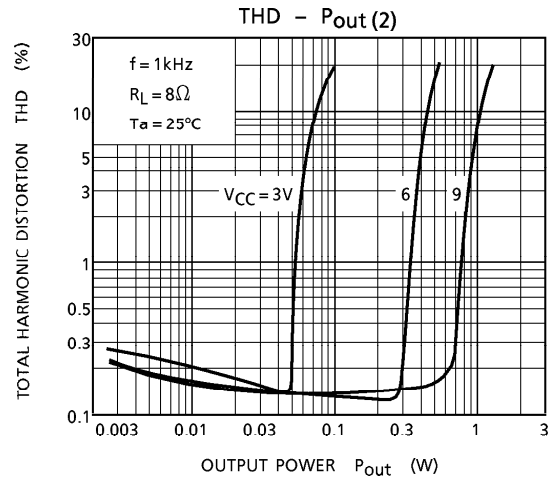
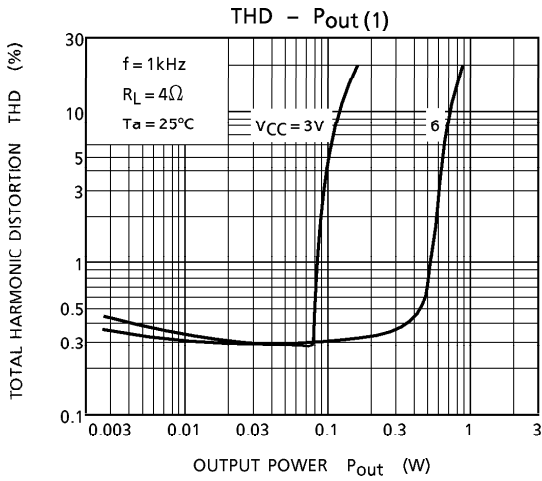

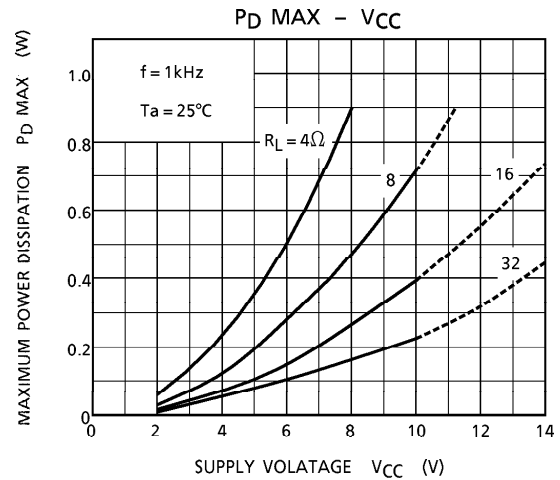
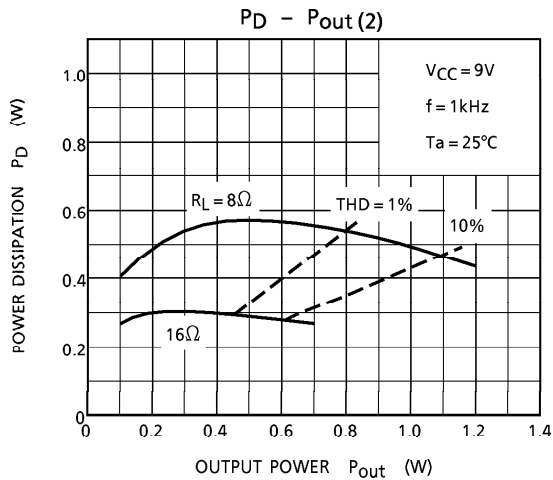
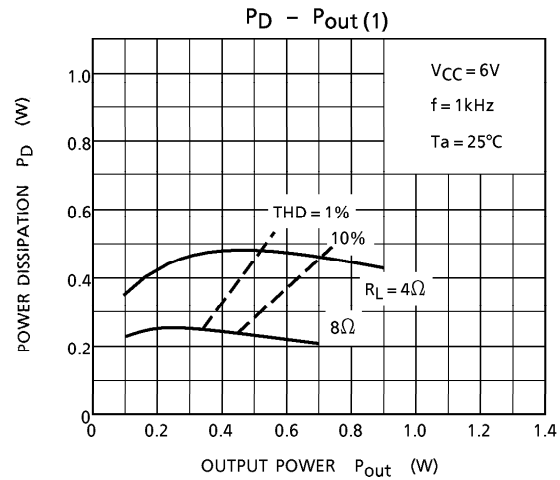
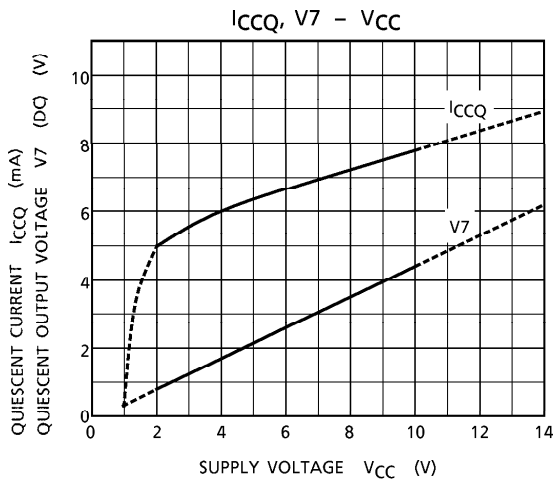
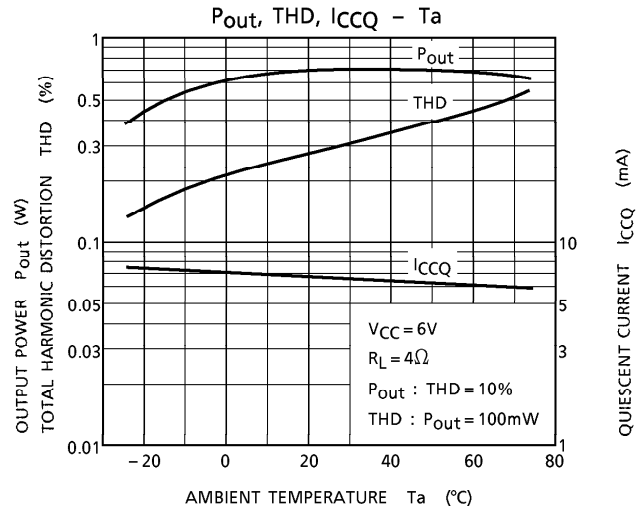
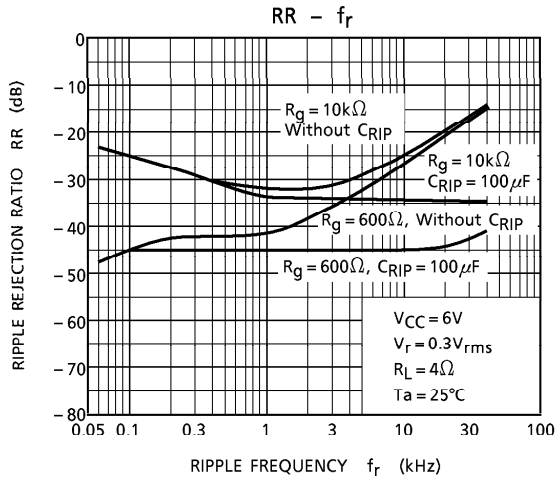

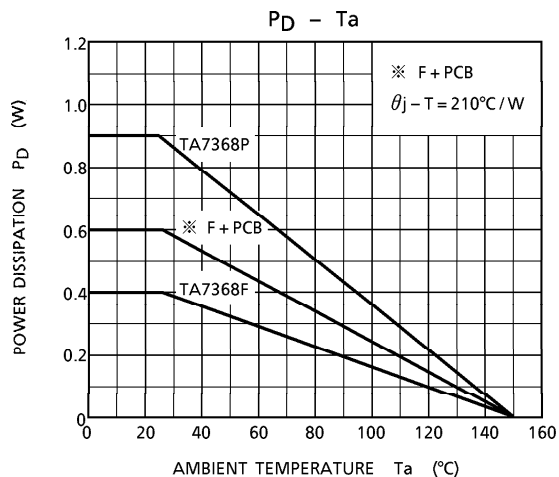

※ F + PCB

By being mounted on certain PCB's, flat packages increase the heat dissipating efficiency.

Data shown on the left is resulted from the measurement on the PCB recommended by Toshiba.

( $\theta_{j-T}$  : Thermal resistance)

Printed circuit board

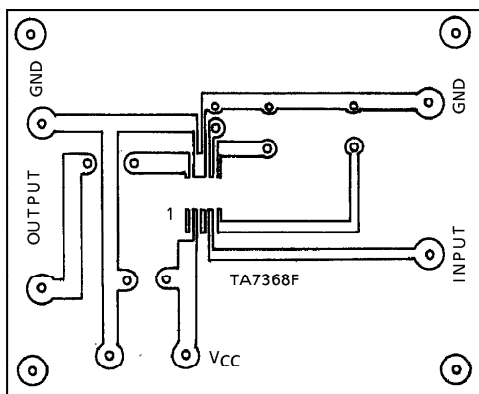

60 × 47.5 (mm)

Material : Phenol resin

Thickness of copper leaf : 35 $\mu$ m

Plate thickness : 1.6mm



**OUTLINE DRAWING**  
SIP9-P-A

Unit : mm

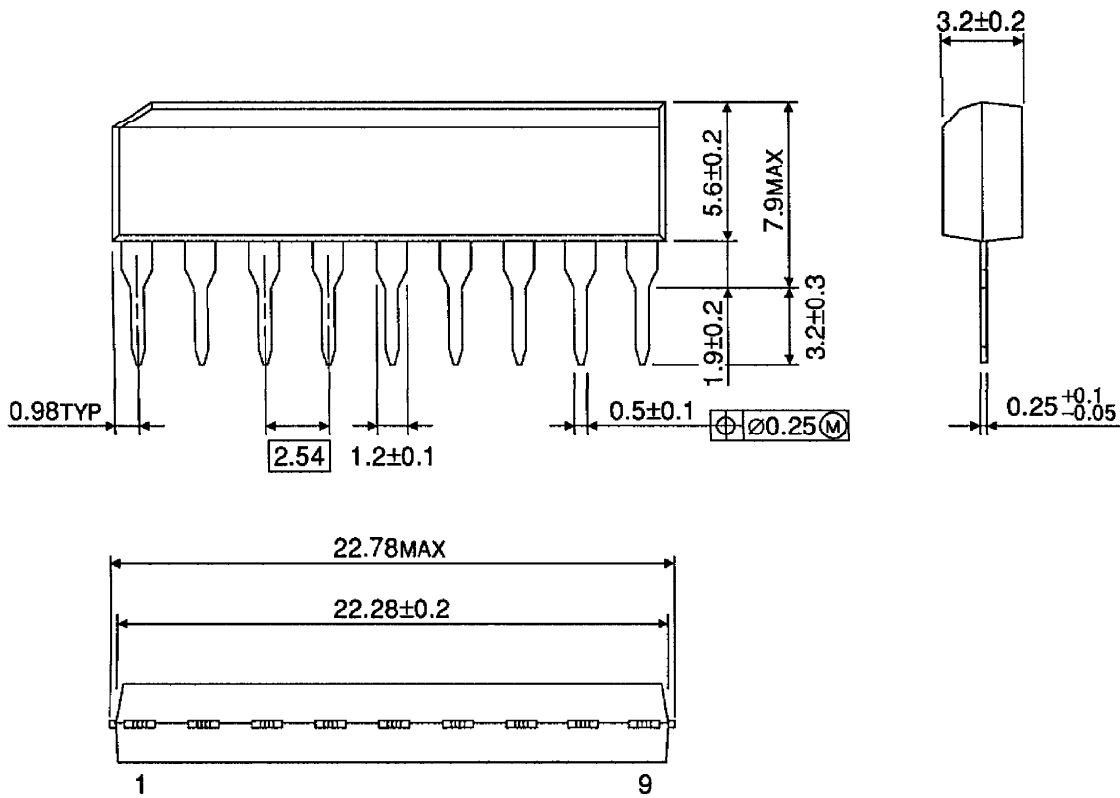

Weight : 0.92g (Typ.)

OUTLINE DRAWING  
SSOP10-P-225

Unit : mm

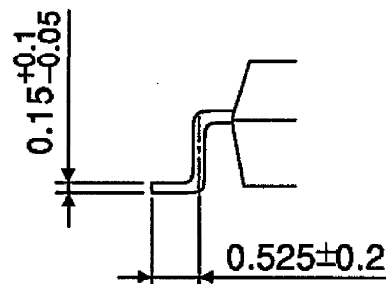
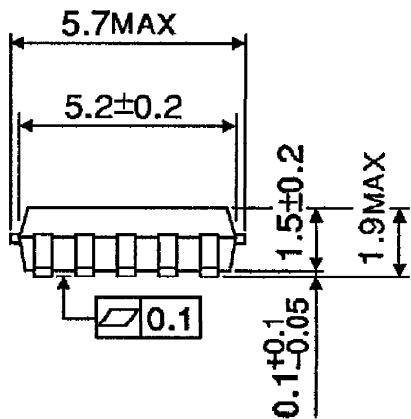
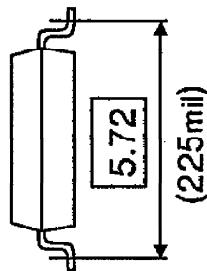
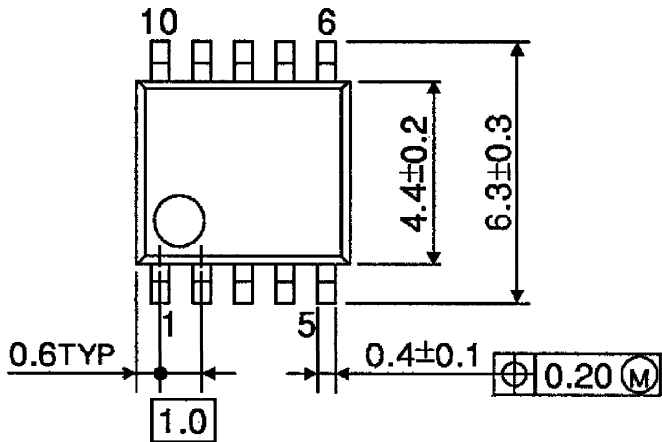

Weight : 0.10g (Typ.)