

## 3V AM / FM 1CHIP TUNER IC

TA8127N and TA8127F are the AM / FM 1Chip Tuner ICs, which are designed for Portable Radios and 3V Headphone Radios.

### FEATURES

- Built-in  
FM F/E, AM/FM IF and FM MPX
- AM Detector Coil and IF Coupling Condenser are not needed.
- Compact Package  
TA8127N : Shrink DIP 24 pin (1.78mm pitch)  
TA8127F : Mini Flat Package 24 pin
- Operating Supply Voltage Range  
 $V_{CC} = 1.8 \sim 7.0V$  ( $T_a = 25^\circ C$ )

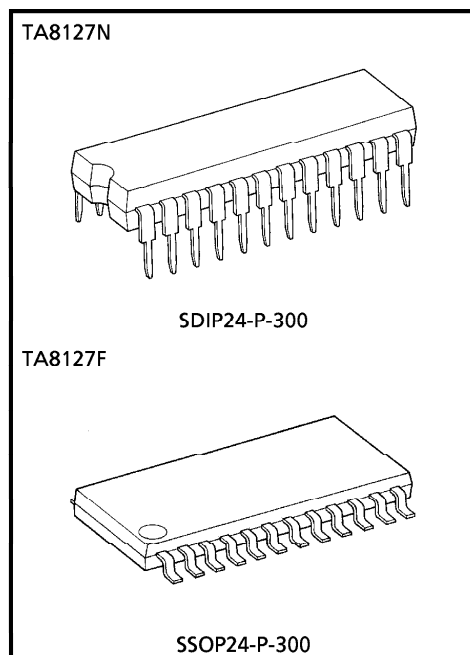

Weight SDIP24-P-300 : 1.2g (Typ.)  
SSOP24-P-300 : 0.31g (Typ.)

**BLOCK DIAGRAM**

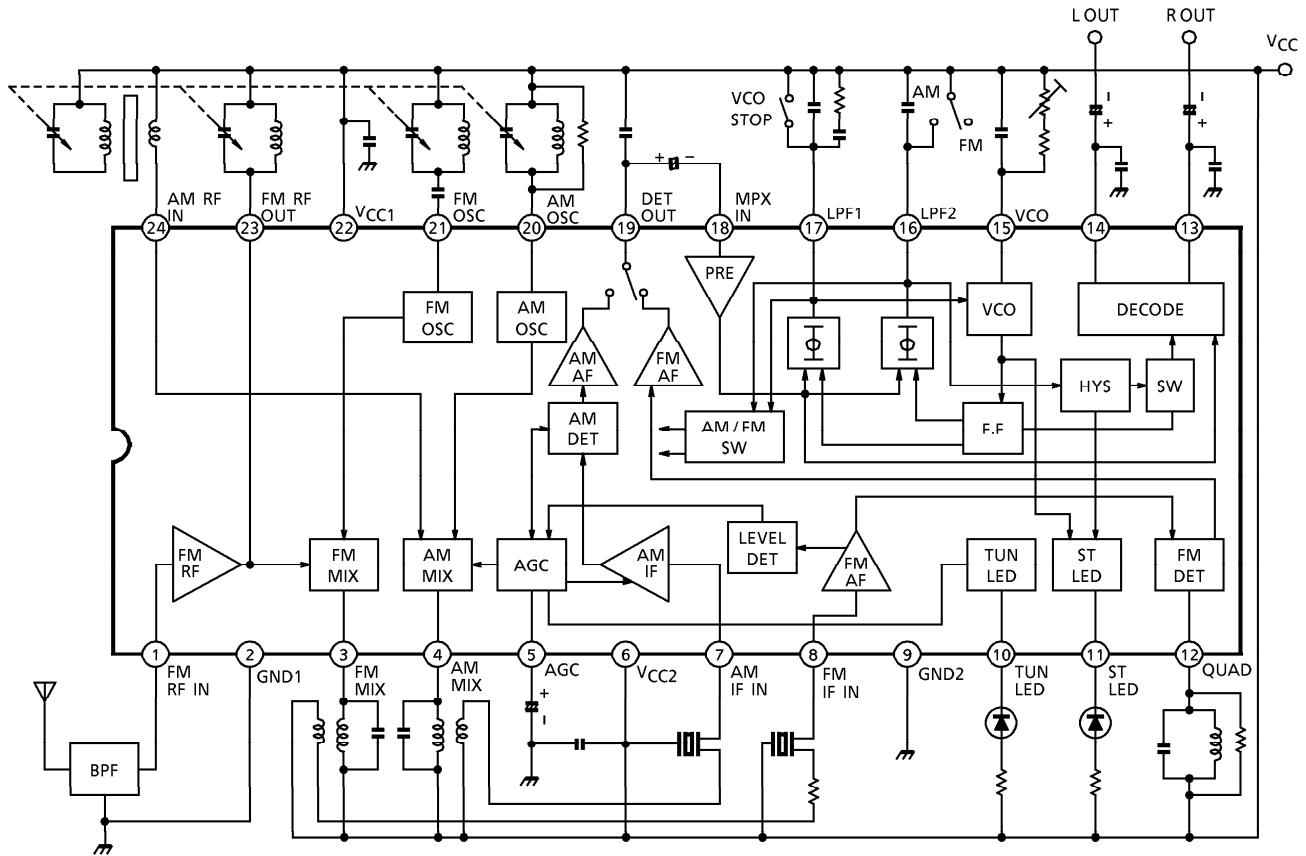

**EXPLANATION OF TERMINALS**

PIN NO.	ITEM	INTERNAL CIRCUIT	DC VOLTAGE (V) (AT NO SIGNAL)	
			AM	FM
1	FM-RF IN		0	0.7
2	GND1 (GND for RF Stage)	—	0	0
3	FM MIX		3.0	3.0
4	AM MIX		3.0	3.0
5	AGC (AM AGC)		0	0
6	VCC2 (VCC for IF/MPX Stage)	—	3.0	3.0
7	AM IF IN		3.0	3.0
8	FM IF IN		3.0	3.0

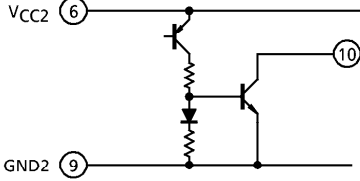
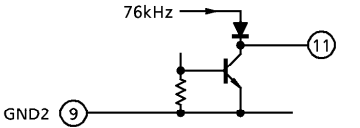
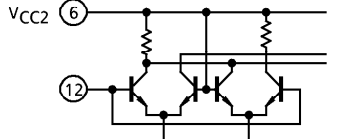
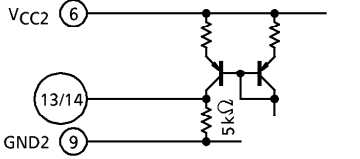
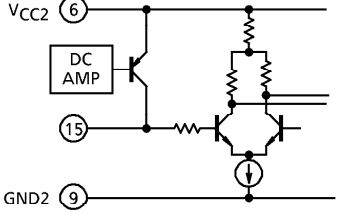
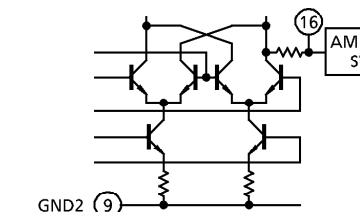
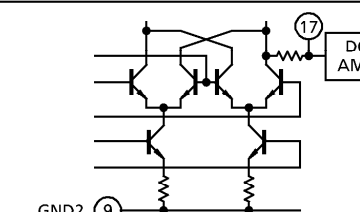
PIN NO.	ITEM	INTERNAL CIRCUIT	DC VOLTAGE (V) (AT NO SIGNAL)	
			AM	FM
9	GND2 (GND for IF /MPX Stage)	—	0	0
10	TUN LED (Tuning LED)		—	—
11	ST LED (Stereo LED)		—	—
12	QUAD (FM QUAD. Detector)		3.0	3.0
13	R-OUT (R-ch Output)		1.0	1.0
14	L-OUT (L-ch Output)			
15	VCO		2.5	2.5 (VCO STOP MODE)
16	LPF2 <ul style="list-style-type: none"> <li>● LPF Terminal for Synchronous Detector</li> <li>● Bias Terminal for AM /FM SW Circuit</li> </ul> $V_{16} = V_{CC} \rightarrow \text{AM (VCO Stop)}$ $V_{16} = \text{Open} \rightarrow \text{FM}$		3.0	2.2 (VCO STOP MODE) 2.7
17	LPF1 <ul style="list-style-type: none"> <li>● LPF Terminal for Phase Detector</li> <li>● VCO Stop Terminal</li> </ul> $V_7 = V_{CC} \rightarrow \text{VCO Stop}$		2.7	2.2

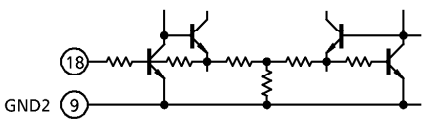
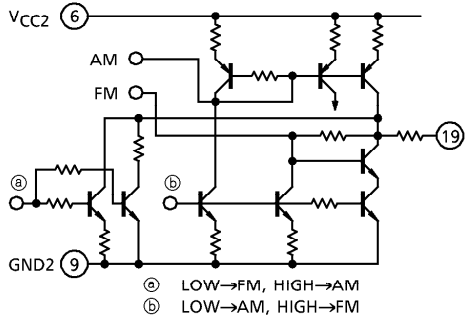
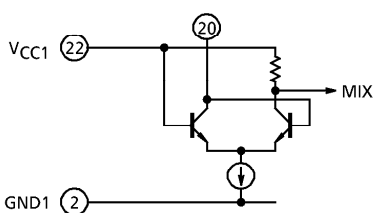
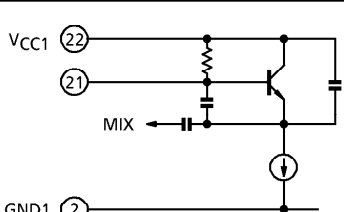
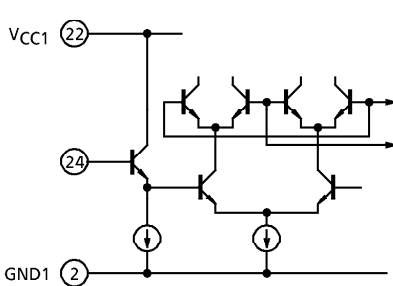
PIN NO.	ITEM	INTERNAL CIRCUIT	DC VOLTAGE (V) (AT NO SIGNAL)	
			AM	FM
18	MPX IN		0.7	0.7
19	DET OUT		1.5	1.2
20	AM OSC		3.0	3.0
21	FM OSC		3.0	3.0
22	VCC1 (VCC for RF Stage)	—	3.0	3.0
23	FM RF OUT	cf. pin①	3.0	3.0
24	AM RF IN		3.0	3.0

**MAXIMUM RATINGS** (Ta = 25°C)

CHARACTERISTIC		SYMBOL	RATING	UNIT
Supply Voltage		V <sub>CC</sub>	8	V
LED Current		I <sub>LED</sub>	10	mA
LED Voltage		V <sub>LED</sub>	8	V
Power Dissipation	TA8127N	P <sub>D</sub> (Note)	1200	mW
	TA8127F		400	
Operating Temperature		T <sub>opr</sub>	- 25~75	°C
Storage Temperature		T <sub>stg</sub>	- 55~150	°C

Note : Derated above 25°C in the proportion of 9.6mW/°C for TA8127N and of 3.2mW/°C for TA8127F.

**ELECTRICAL CHARACTERISTICS**

Unless otherwise specified,

Ta = 25°C, VCC = 3V, F/E : f = 83MHz, fm = 1kHz

FM IF : f = 10.7MHz, Δf = ± 22.5kHz, fm = 1kHz

AM : f = 1MHz, MOD = 30%, fm = 1kHz

MPX : fm = 1kHz

CHARACTERISTIC		SYMBOL	TEST CIR- CUIT	TEST CONDITION	MIN.	TYP.	MAX.	UNIT
Supply Current		ICC (FM)	1	Vin = 0, FM Mode	—	13.2	20.0	mA
		ICC (AM)	1	Vin = 0, AM Mode	—	8.4	13.5	
F/E	Input Limiting Voltage	Vin (lim.)	1	- 3dB Limiting	—	10.0	—	dB $\mu$ V EMF
	Local OSC Voltage	VOSC	2	fOSC = 72.3MHz	—	105	—	mVrms
FM IF	Input Limiting Voltage	Vin (lim.) IF	1	- 3dB Limiting	40	46	53	dB $\mu$ V EMF
	Recovered Output Voltage	VOD	1	Vin = 80dB $\mu$ V EMF	55	80	110	mVrms
	Signal to Noise Ratio	S/N	1	Vin = 80dB $\mu$ V EMF	—	70	—	dB
	Total Harmonic Distortion	THD	1	Vin = 80dB $\mu$ V EMF	—	0.4	—	%
	AM Rejection Ratio	AMR	1	Vin = 80dB $\mu$ V EMF	—	32	—	dB
	Lamp ON sensitivity	VL	1	IL = 1mA	45	51	56	dB $\mu$ V EMF
AM	Gain	Gv	1	Vin = 26dB $\mu$ V EMF	40	70	110	mVrms
	Recovered Output Voltage	VOD	1	Vin = 60dB $\mu$ V EMF	55	80	110	
	Signal to Noise Ratio	S/N	1	Vin = 60dB $\mu$ V EMF	—	42	—	dB
	Total Harmonic Distortion	THD	1	Vin = 60dB $\mu$ V EMF	—	1.0	—	%
	Lamp ON Sensitivity	VL	1	IL = 1mA	20	25	30	dB $\mu$ V EMF
Pin <sup>①</sup> Output Resistance		R19	1	FM Mode	—	0.75	—	k $\Omega$
				AM Mode	—	12.5	—	

CHARACTERISTIC		SYMBOL	TEST CIRCUIT	TEST CONDITION	MIN.	TYP.	MAX.	UNIT	
MPX	Input Resistance	$R_{IN}$	—	—	—	24	—	$k\Omega$	
	Output Resistance	$R_{OUT}$	—	—	—	5	—		
	Max. Composite Signal Input Voltage	$V_{in}$ (max.) STEREO	1	L + R = 90%, P = 10% $f_m = 1\text{kHz}$ , THD = 3%	—	350	—	$\text{mV}_{rms}$	
	Separation	Sep	1	L + R = $135\text{mV}_{rms}$ P = $15\text{mV}_{rms}$	$f_m = 100\text{Hz}$	—	42	—	dB
					$f_m = 1\text{kHz}$	35	42	—	
					$f_m = 10\text{kHz}$	—	42	—	
	Total Harmonic Distortion	Monaural	THD (MONAURAL)	1	$V_{in} = 150\text{mV}_{rms}$	—	0.2	—	%
		Stereo	THD (STEREO)		L + R = $135\text{mV}_{rms}$ , P = $15\text{mV}_{rms}$	—	0.2	—	
	Voltage Gain		$G_V$ (MPX)	1	$V_{in} = 150\text{mV}_{rms}$	-5	-3	-1	dB
	Channel Balance		C.B.	1	$V_{in} = 150\text{mV}_{rms}$	-2	0	2	
	Stereo Lamp Sensitivity	ON	$V_L$ (ON)	1	Pilot Input	—	8	16	$\text{mV}_{rms}$
OFF		$V_L$ (OFF)	Pilot Input		2	6	—		
Stereo Lamp Hysteresis		$V_H$	1	To LED turn off from LED turn on	—	2	—	$\text{mV}_{rms}$	
Capture Range		C.R.	1	P = $15\text{mV}_{rms}$	—	$\pm 3$	—	%	
Signal to Noise Ratio		S/N	1	$V_{in} = 150\text{mV}_{rms}$	—	70	—	dB	



**TEST CIRCUIT 1**

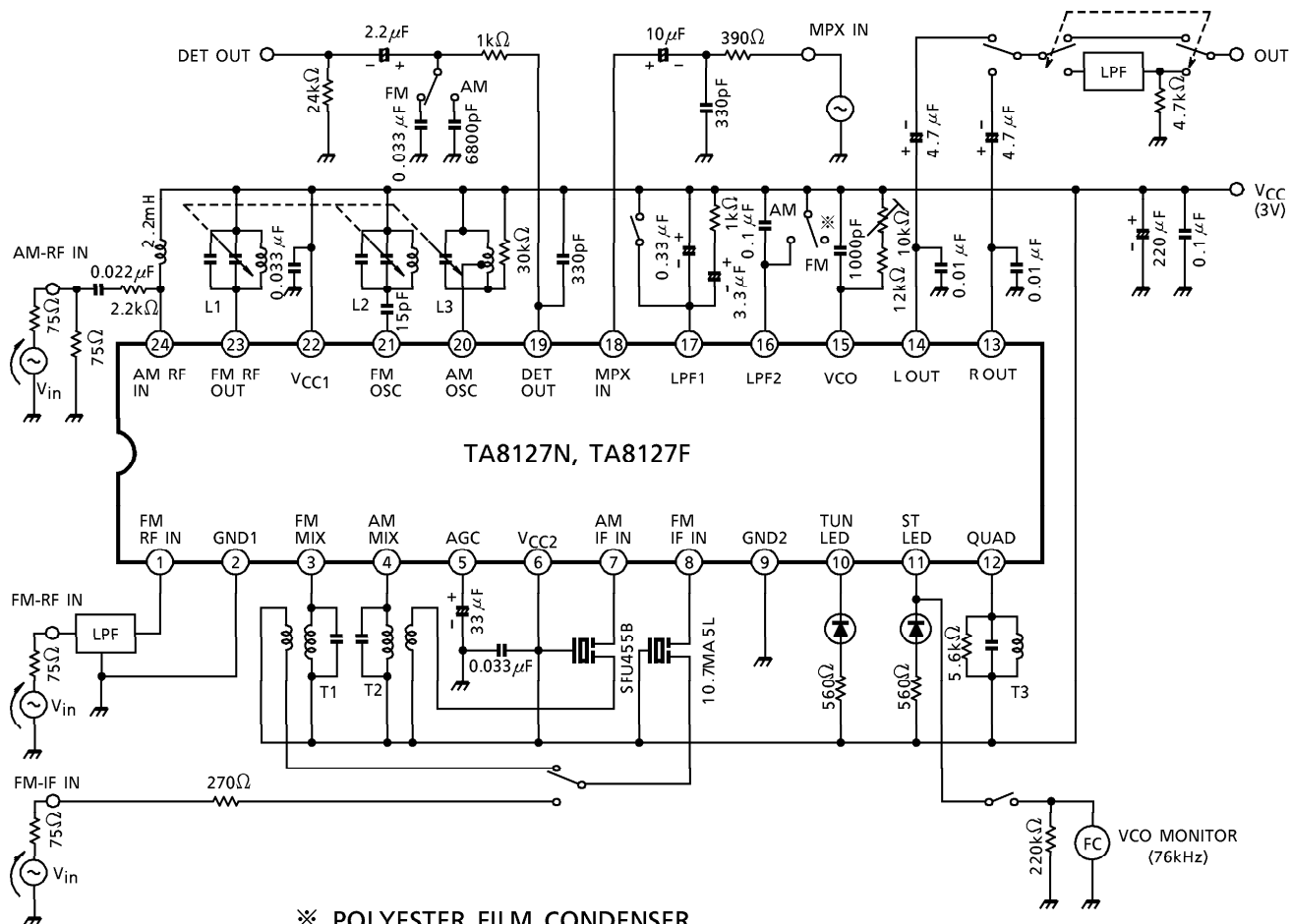

※ POLYESTER FILM CONDENSER

Using other types of condensers, there are some cases that the MPX does not do normal stereo action at high temperature or low temperature.

**TEST CIRCUIT 2**

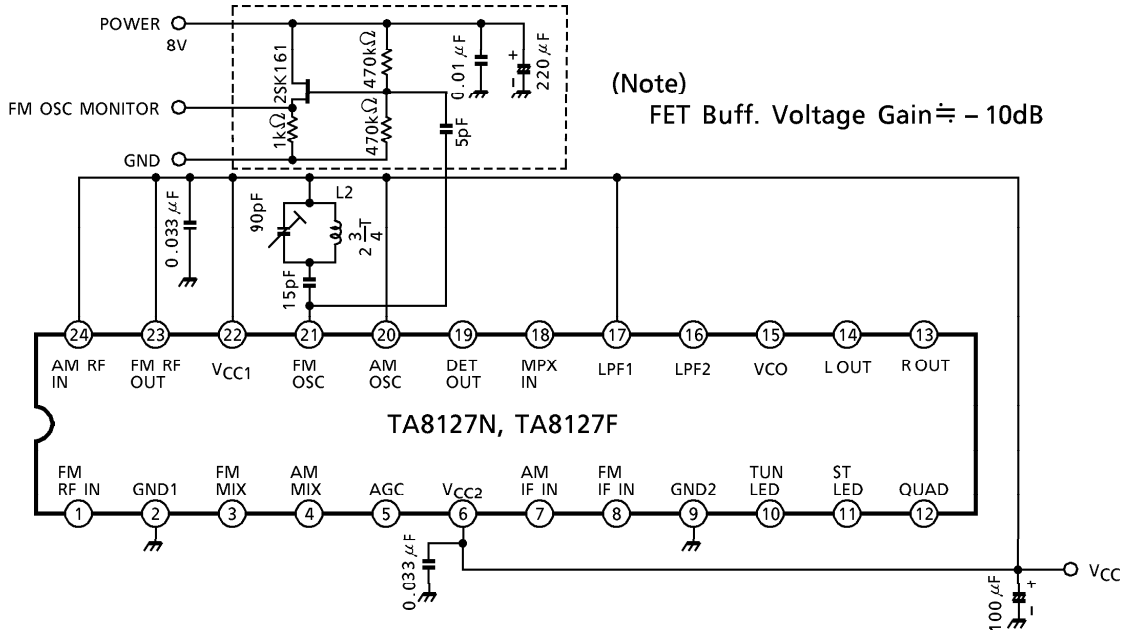

**COIL DATA**

COIL No.	TEST FREQ. (Hz)	L ( $\mu$ H)	C <sub>o</sub> (pF)	Q <sub>o</sub>	TURNS					WIRE (mm $\phi$ )	REFERENCE
					1-2	2-3	1-3	1-4	4-6		
L <sub>1</sub> FM RF	100M	—	—	100	—	—	—	2 $\frac{1}{2}$	—	0.5UEW	Ⓢ 53T-037-202
L <sub>2</sub> FM OSC	100M	—	—	100	—	—	2 $\frac{3}{4}$	—	—	0.5UEW	Ⓢ 0258-244
L <sub>3</sub> AM OSC	796k	288	—	115	13	73	—	—	—	0.08UEW	Ⓢ 4147-1356-038
T <sub>1</sub> FM MIX	10.7M	—	75	100	—	—	13	—	2	0.1UEW	Ⓢ 2153-414-041
T <sub>2</sub> AM MIX	455k	—	180	120	—	—	180	—	15	0.08UEW	Ⓢ 2150-2162-165
T <sub>3</sub> FM DET	10.7M	—	47	165	—	—	16	—	—	0.09UEW	Ⓢ 2153-4095-122

Ⓢ : SUMIDA ELECTRIC CO., LTD

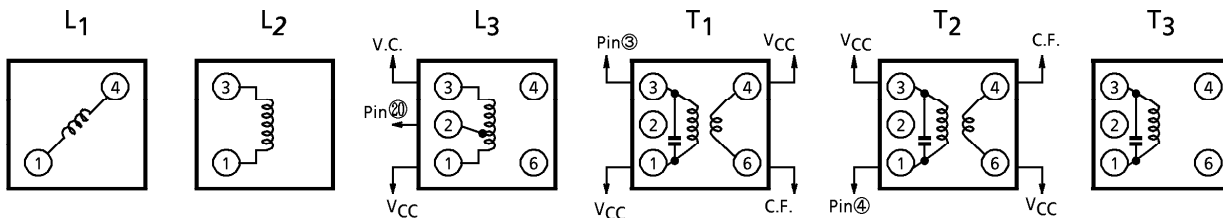

**HINT ON USE OF TA8127N and TA8127F**

External Parts of MPX VCO

(1) Temperature characteristic of MPX VCO free-run frequency. The temperature characteristic of MPX VCO is shown in the diagram as below. Select one with a better temperature characteristic (C, R and VR.) in use. We recommend,

- C : POLYESTER FILM
- R, VR. : CARBON FILM

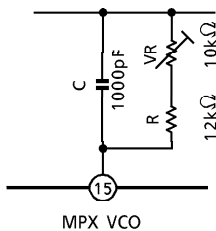
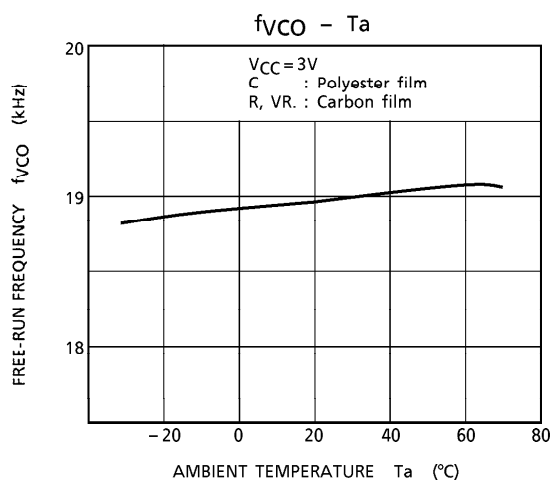

(2) Value of the external parts

We recommend to set up these value as below.

- R = 12kΩ
- VR = 10kΩ
- C = 1000pF

FM (F/E + IF)  
VOD, V<sub>no</sub>, THD, AMR - V<sub>in</sub>

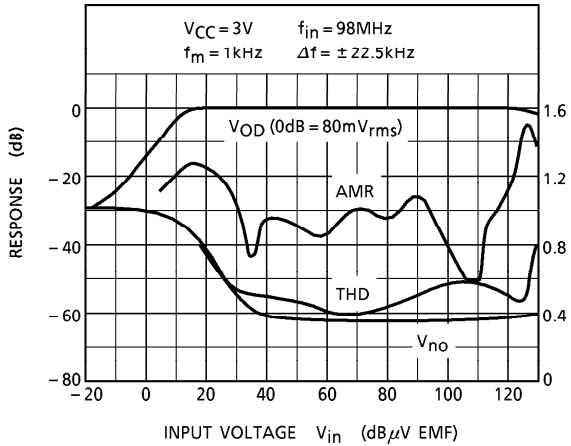

FM (IF)  
VOD, V<sub>no</sub>, THD, AMR - V<sub>in</sub>

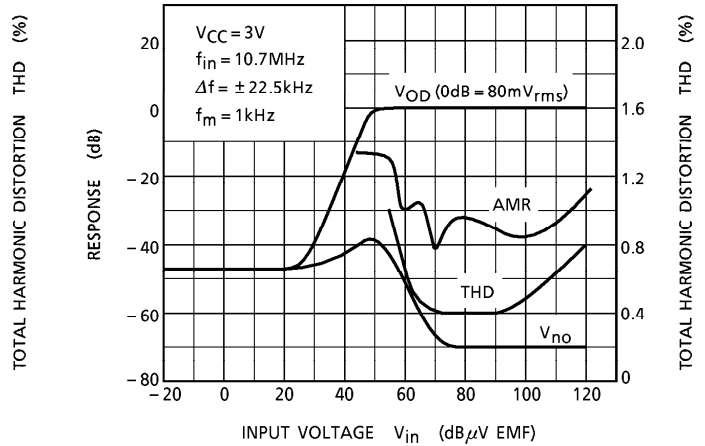

FM (IF)  
VOD, THD -  $\Delta f$

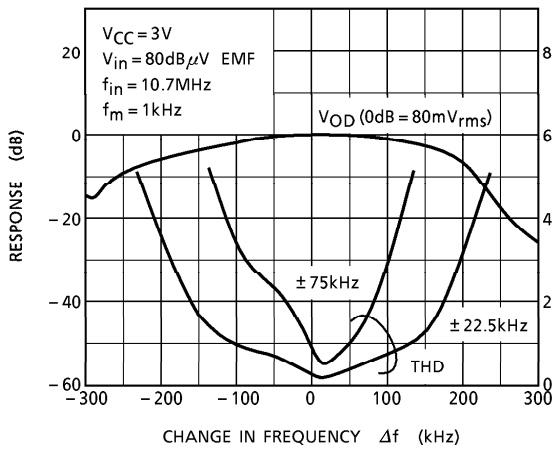

FM (IF)  
VOD, V<sub>in</sub> (lim.) - V<sub>CC</sub>

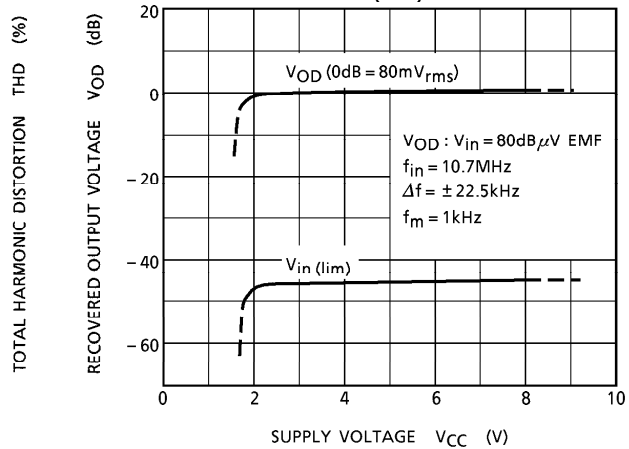

FM (IF)  
VOD - T<sub>a</sub>

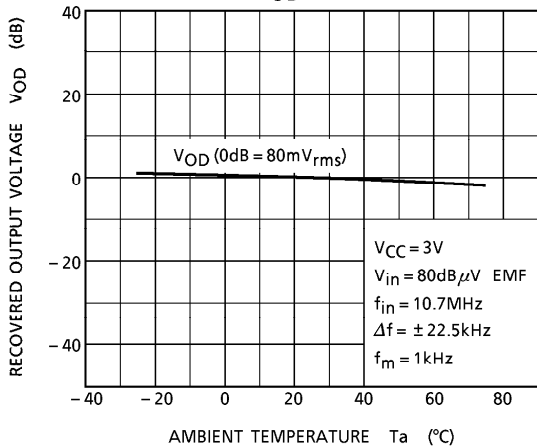

AM  
VOD, V<sub>no</sub>, THD - V<sub>in</sub>

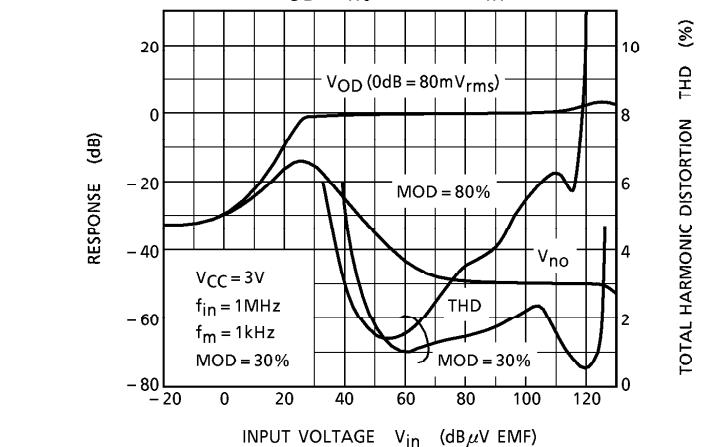

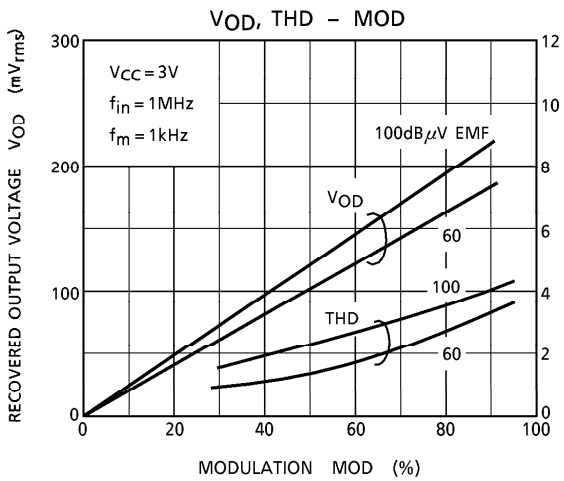

TOTAL HARMONIC DISTORTION THD (%)

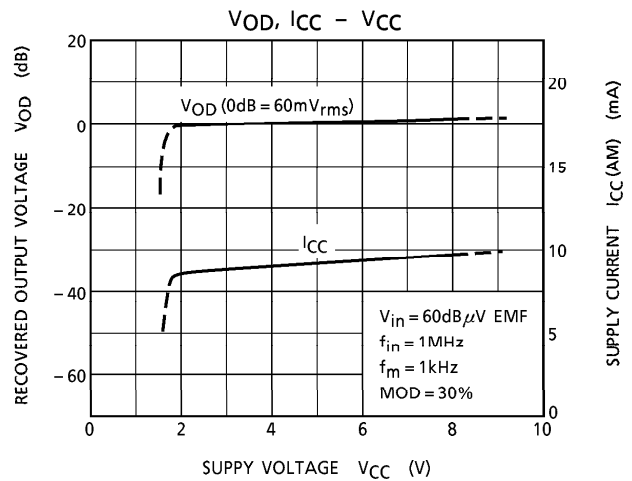

SUPPLY CURRENT  $I_{CC}$  (mA)

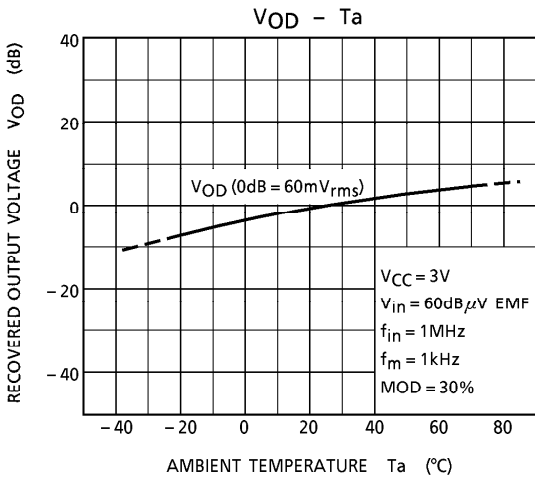

MPX

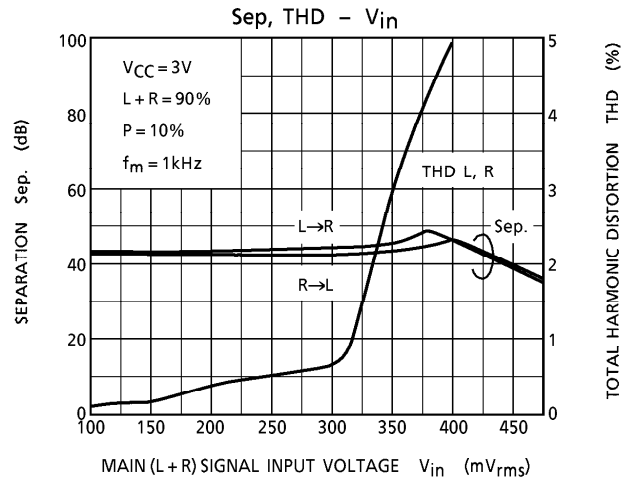

TOTAL HARMONIC DISTORTION THD (%)

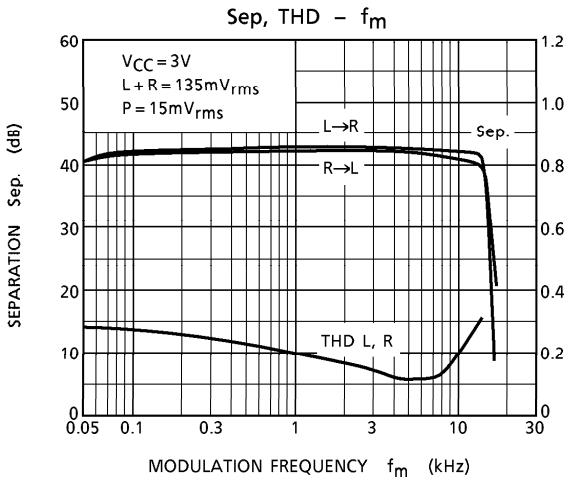

TOTAL HARMONIC DISTORTION THD (%)

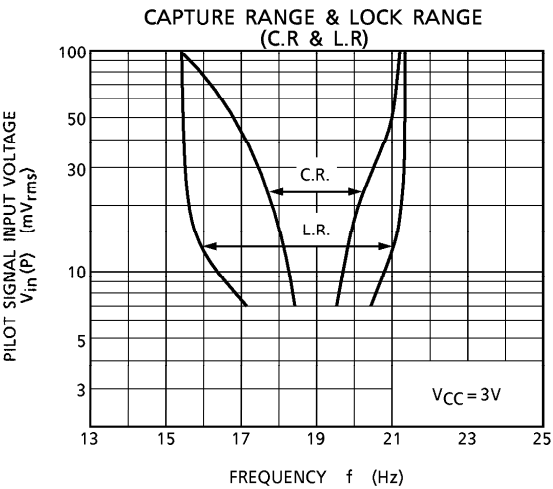

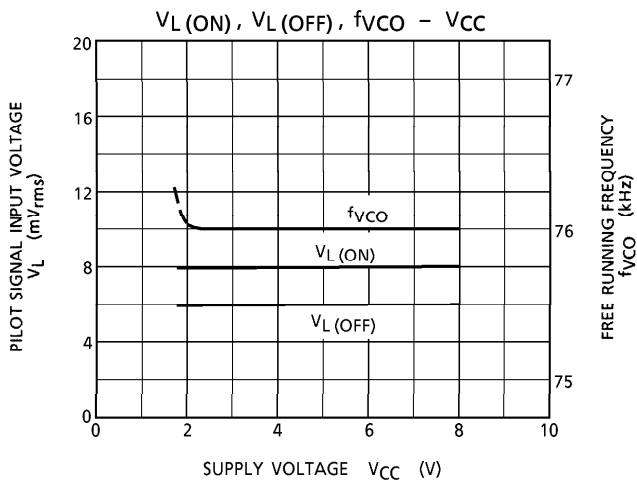
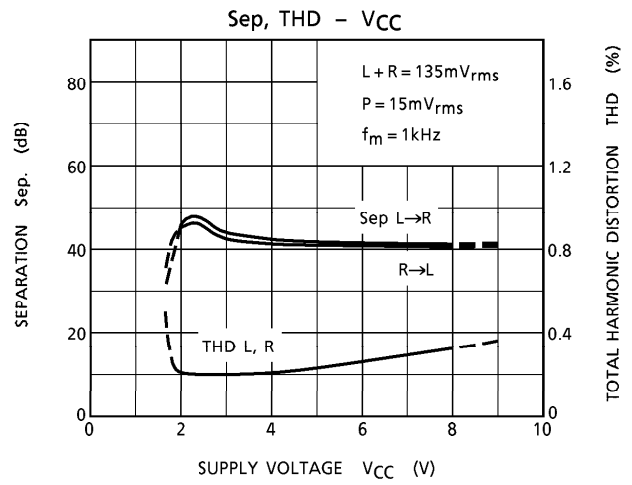
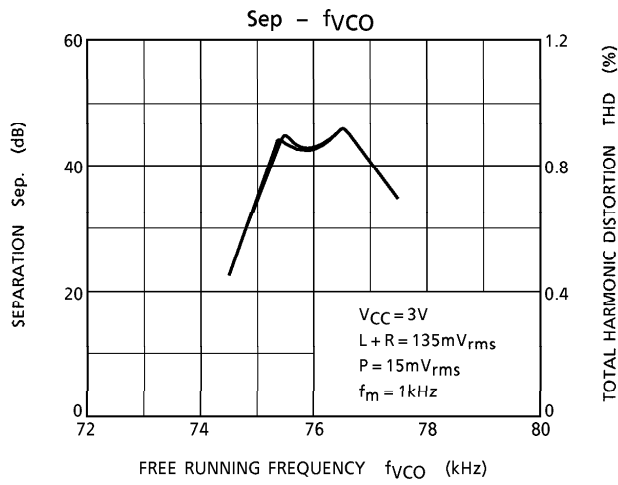

**OUTLINE DRAWING**  
SDIP24-P-300

Unit : mm

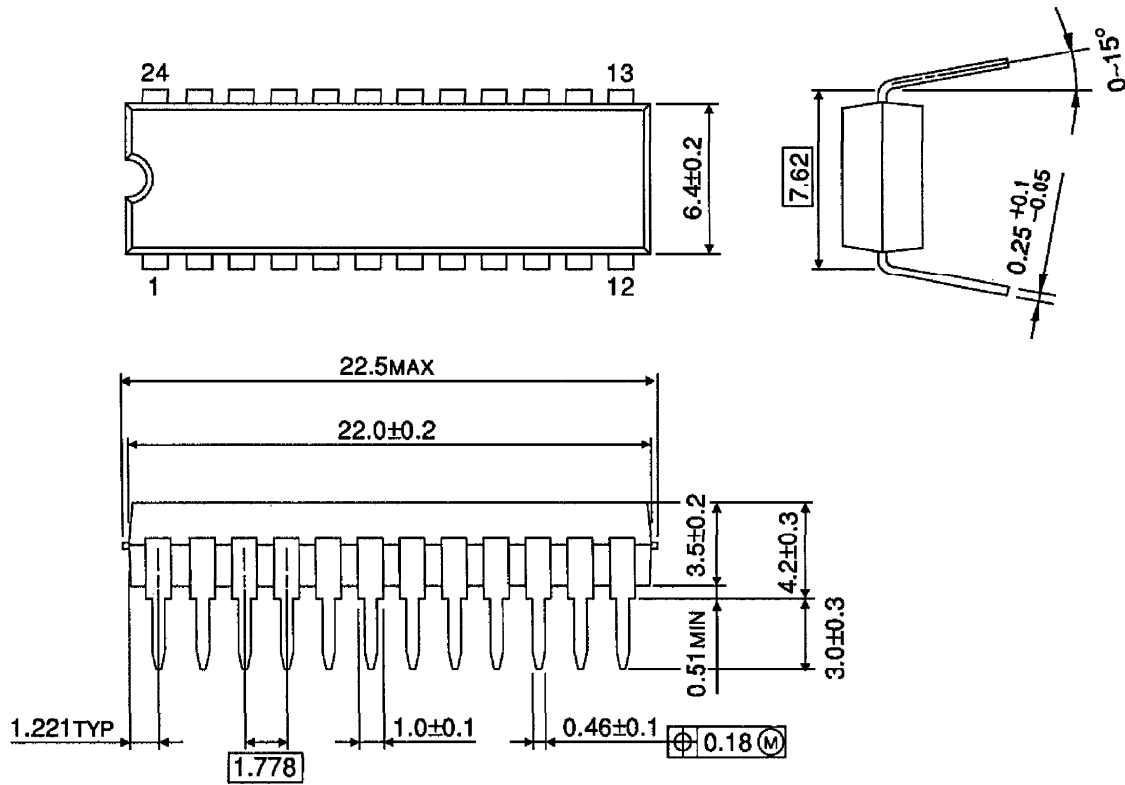

Weight : 1.2g (Typ.)

TA8127N - 15
1994 - 3 - 8
<b>TOSHIBA CORPORATION</b>

**OUTLINE DRAWING**  
SSOP24-P-300

Unit : mm

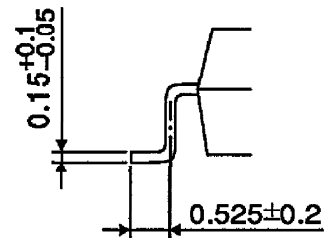
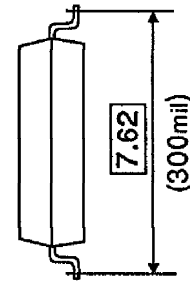
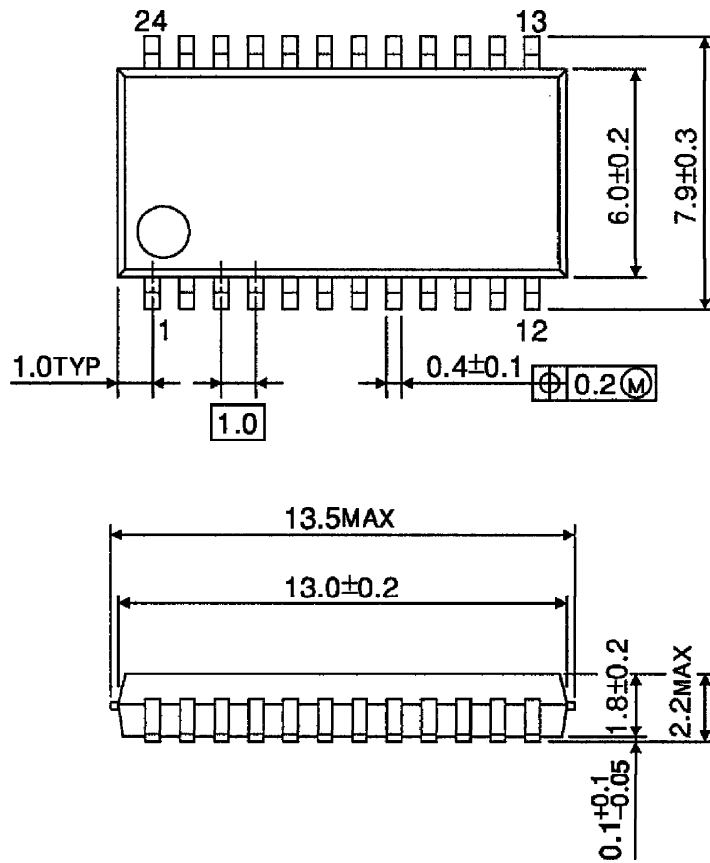

Weight : 0.31g (Typ.)

TA8127N - 16*
1994 - 3 - 8
<b>TOSHIBA CORPORATION</b>