

TA8464K

DUAL POWER OPERATIONAL AMPLIFIER

The TA8464K is a dual power operational amplifier with the output current 1.2 A (PEAK).

This amplifier is usable for CD player arm driver, brushed motor forward / reverse rotation control driver, and FDD / HDD voice coil motor.

Furthermore, this amplifier is best suited for LDP focus tracking actuator driver because of its high through rate.

FEATURES

- Provided with a Current Limiter.
- High Output Current : I_O (PEAK) = 1.2 A
- Internal Phase Compensation Type.
- Less Crosstalk : C_T = 55 dB (Typ.)
- High Slew Rate : SR = 1.0 V / μ s (Typ.)

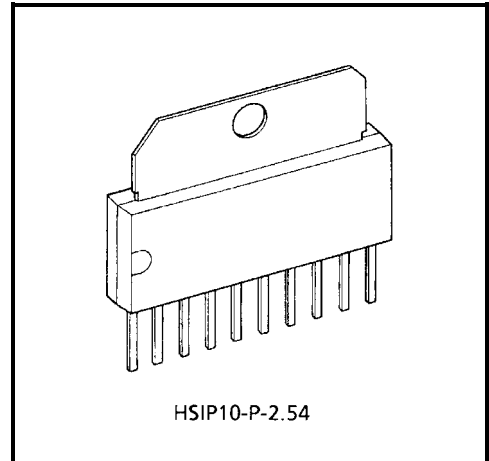

Weight: 2.47 g (Typ.)

BLOCK DIAGRAM

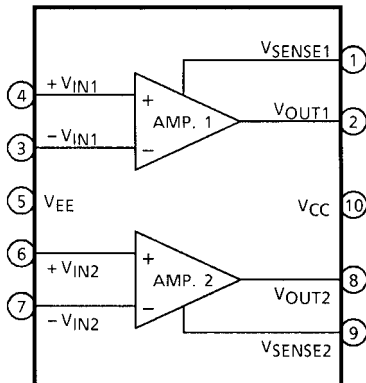

PIN FUNCTION

PIN No.	SYMBOL	FUNCTIONAL DESCRIPTION
1	V _{SENSE1}	AMP. 1 output current detective terminal
2	V _{OUT1}	AMP. 1 output terminal
3	-V _{IN1}	AMP. 1 input terminal (-)
4	+V _{IN1}	AMP. 1 input terminal (+)
5	V _{EE}	Negative-side voltage supply terminal
6	+V _{IN2}	AMP. 2 input terminal (+)
7	-V _{IN2}	AMP. 2 input terminal (-)
8	V _{OUT2}	AMP. 2 output terminal
9	V _{SENSE2}	AMP. 2 output current detective terminal
10	V _{CC}	Positive-side voltage supply terminal

MAXIMUM RATINGS (Ta = 25°C)

CHARACTERISTIC	SYMBOL	RATING	UNIT
Supply Voltage	V _{CC} , V _{EE}	±18	V
Output Current	I _O (PEAK)	1.2	A
Power Dissipation	P _D	12.5 (Note)	W
Operating Temperature	T _{opr}	-30~75	°C
Storage Temperature	T _{stg}	-55~150	°C

Note: T_c = 25°C

ELECTRICAL CHARACTERISTICS

(Unless otherwise specified, V_{CC} = 15 V, V_{EE} = -15 V, Ta = 25°C)

CHARACTERISTIC	SYMBOL	TEST CIRCUIT	TEST CONDITION	MIN	TYP.	MAX	UNIT
Supply Current	I _{CC}	—	—	—	17	25	mA
Input Offset Current	I _{IO}	—	—	—	3	100	nA
Input Bias Current	I _I	—	—	—	98	300	nA
Input Offset Voltage	V _{IO}	—	—	—	0	7	mV
Maximum Output Voltage	Upper	V _{OH}	V _{CC} = ±15 V, I _O = 300 mA	12.2	13.3	—	V
	Lower	V _{OL}		-12.2	-13.3	—	
	Upper	V _{OH}	V _{CC} = ±6 V, I _O = 1 A	2.0	3.9	—	V
	Lower	V _{OL}		-2.0	-4.0	—	
Open Loop Gain	G _{VO}	—	—	—	80	—	dB
Input Common Mode Voltage Range	CMR	—	—	±13	±14	—	V
Common Mode Rejection Ratio	CMRR	—	V _{IN} = -10~10 V	90	113	—	dB
Supply Voltage Rejection Ratio	SVRR	—	V _{CC} = -V _{EE} = 6~15 V±1 V	—	65	100	μV / V
Slew Rate	SR	—	—	—	1.0	—	V / μs
Output Limiting Current	I _{SC}	—	R _{SC} = 0.68 Ω	0.8	1.0	—	A
Crosstalk	C _T	—	V _{IN} = -14~14 V	—	55	—	dB
Slew Rate Symmetry	SR'	1	INPUT : Duty (49 : 51 / 51 : 49) Square wave	—	0.02	1.0	V

TEST CIRCUIT 1

Slew rate, symmetry SR'

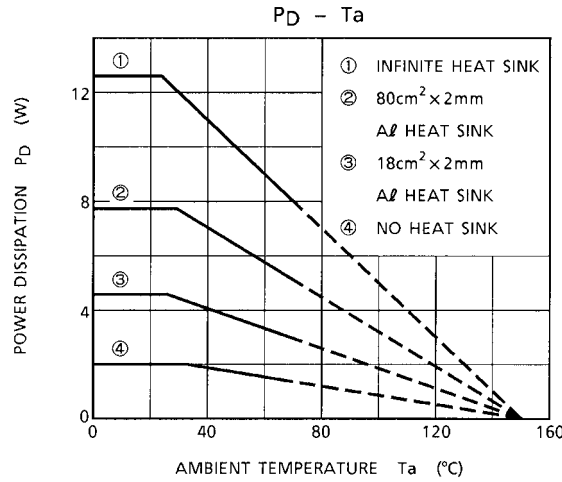
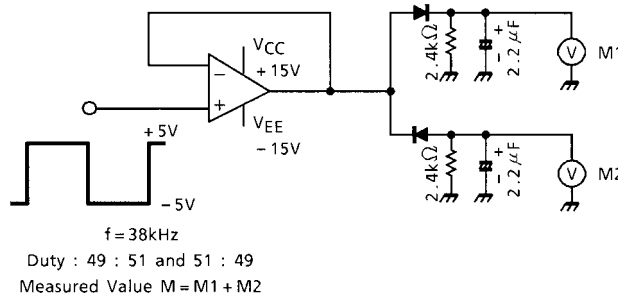

APPLICATION CIRCUIT 1

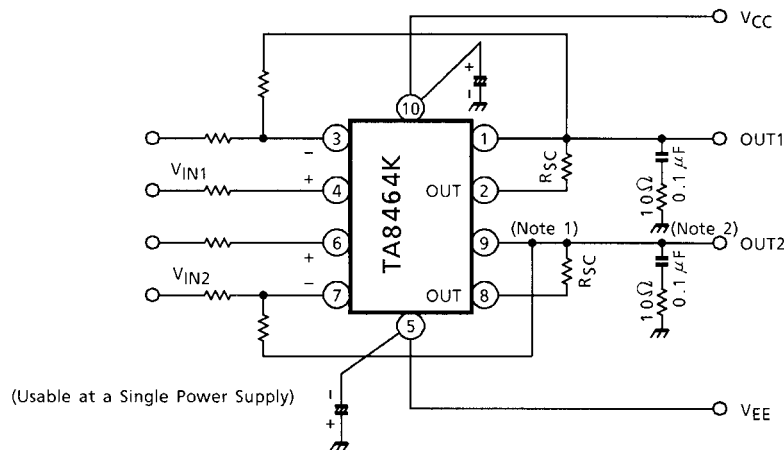

Note 1: $I_{SC} \approx \frac{0.7(V)}{R_{SC}(\Omega)} (A)$

Note 2: If crosstalk is recognizable remarkably in applications above 80 kHz, change a capacitor to one having a value of about 0.33 μF as a compensating circuit. Further, no resistor is needed in this case.

Note 3: Utmost care is necessary in the design of the output line, V_{CC} and GND line since IC may be destroyed due to short-circuit between outputs, air contamination fault, or fault by improper grounding.

APPLICATION CIRCUIT 2

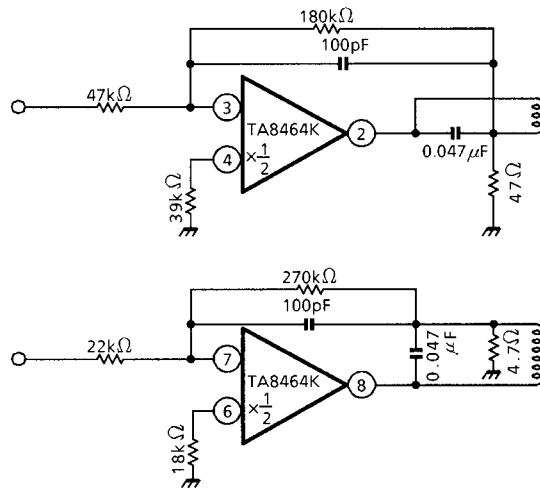

APPLICATION CIRCUIT 3

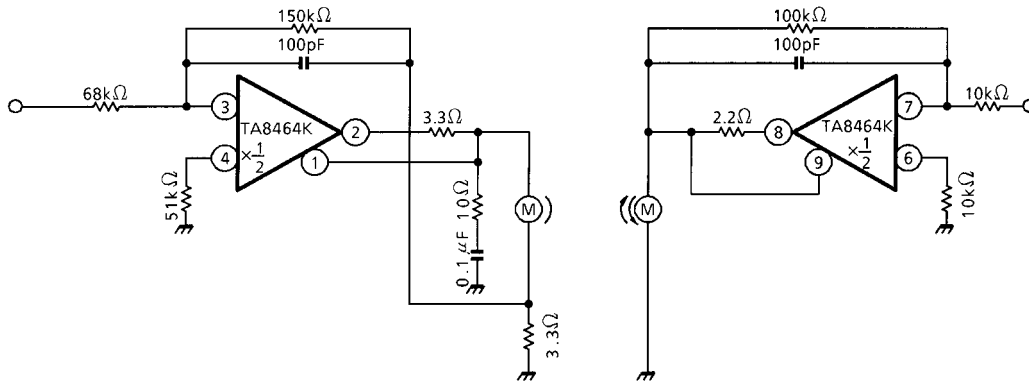

PACKAGE DIMENSIONS

HSIP10-P-2.54

Unit : mm

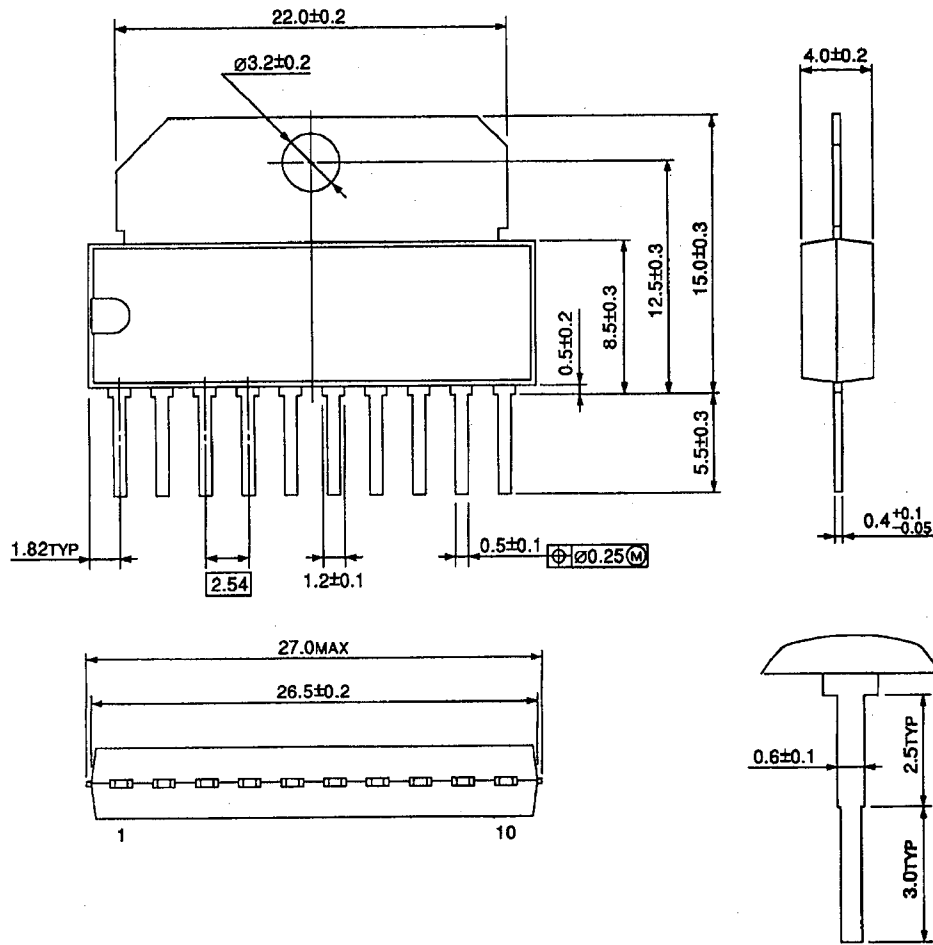

Weight : 2.47 g (Typ.)

RESTRICTIONS ON PRODUCT USE

000707EBA

- TOSHIBA is continually working to improve the quality and reliability of its products. Nevertheless, semiconductor devices in general can malfunction or fail due to their inherent electrical sensitivity and vulnerability to physical stress. It is the responsibility of the buyer, when utilizing TOSHIBA products, to comply with the standards of safety in making a safe design for the entire system, and to avoid situations in which a malfunction or failure of such TOSHIBA products could cause loss of human life, bodily injury or damage to property.
In developing your designs, please ensure that TOSHIBA products are used within specified operating ranges as set forth in the most recent TOSHIBA products specifications. Also, please keep in mind the precautions and conditions set forth in the "Handling Guide for Semiconductor Devices," or "TOSHIBA Semiconductor Reliability Handbook" etc..
- The TOSHIBA products listed in this document are intended for usage in general electronics applications (computer, personal equipment, office equipment, measuring equipment, industrial robotics, domestic appliances, etc.). These TOSHIBA products are neither intended nor warranted for usage in equipment that requires extraordinarily high quality and/or reliability or a malfunction or failure of which may cause loss of human life or bodily injury ("Unintended Usage"). Unintended Usage include atomic energy control instruments, airplane or spaceship instruments, transportation instruments, traffic signal instruments, combustion control instruments, medical instruments, all types of safety devices, etc.. Unintended Usage of TOSHIBA products listed in this document shall be made at the customer's own risk.
- The products described in this document are subject to the foreign exchange and foreign trade laws.
- The information contained herein is presented only as a guide for the applications of our products. No responsibility is assumed by TOSHIBA CORPORATION for any infringements of intellectual property or other rights of the third parties which may result from its use. No license is granted by implication or otherwise under any intellectual property or other rights of TOSHIBA CORPORATION or others.
- The information contained herein is subject to change without notice.

This datasheet has been download from:

www.datasheetcatalog.com

Datasheets for electronics components.