

# LM78S40 Universal Switching Regulator Subsystem

## General Description

The LM78S40 is a monolithic regulator subsystem consisting of all the active building blocks necessary for switching regulator systems. The device consists of a temperature compensated voltage reference, a duty-cycle controllable oscillator with an active current limit circuit, an error amplifier, high current, high voltage output switch, a power diode and an uncommitted operational amplifier. The device can drive external NPN or PNP transistors when currents in excess of 1.5A or voltages in excess of 40V are required. The device can be used for step-down, step-up or inverting switching regulators as well as for series pass regulators. It features wide supply voltage range, low standby power dissipation, high efficiency and low drift. It is useful for any stand-alone, low part count switching system and works extremely well in battery operated systems.

## Features

- Step-up, step-down or inverting switching regulators
- Output adjustable from 1.25V to 40V
- Peak currents to 1.5A without external transistors
- Operation from 2.5V to 40V input
- Low standby current drain
- 80 dB line and load regulation
- High gain, high current, independent op amp
- Pulse width modulation with no double pulsing

## Block and Connection Diagrams

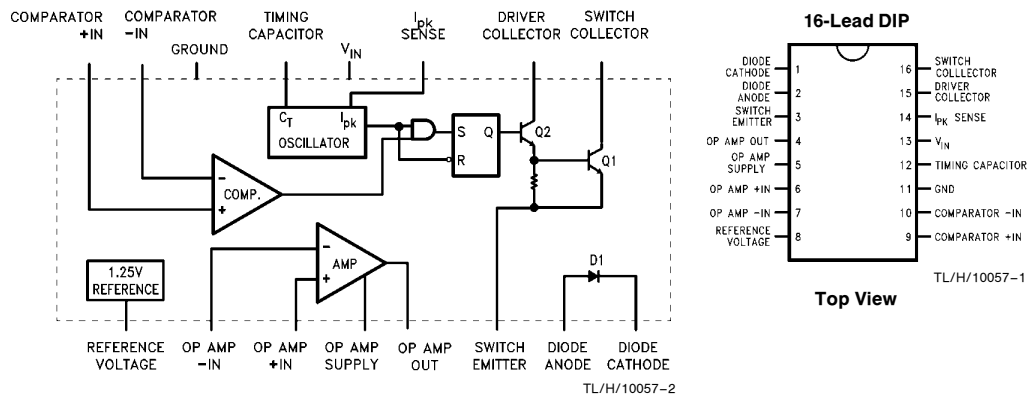

## Ordering Information

Part Number	NS Package	Temperature Range
LM78S40J/883	J16A Ceramic DIP	-55°C to +125°C
LM78S40N	N16E Molded DIP	-40°C to +125°C
LM78S40CN	N16E Molded DIP	0°C to +70°C

## Absolute Maximum Ratings

If Military/Aerospace specified devices are required, please contact the National Semiconductor Sales Office/Distributors for availability and specifications.

Storage Temperature Range	
Ceramic DIP	–65°C to +175°C
Molded DIP	–65°C to +150°C
Operating Temperature Range	
Extended (LM78S40J)	–55°C to +125°C
Industrial (LM78S40N)	–40°C to +125°C
Commercial (LM78S40CN)	0°C to +70°C
Lead Temperature	
Ceramic DIP (Soldering, 60 sec.)	300°C
Molded DIP (Soldering, 10 sec.)	265°C
Internal Power Dissipation (Notes 1, 2)	
16L-Ceramic DIP	1.50W
16L-Molded DIP	1.04W
Input Voltage from $V_{IN}$ to GND	40V
Input Voltage from $V^+$ (Op Amp) to GND	40V

Common Mode Input Range (Comparator and Op Amp)	–0.3 to $V^+$
Differential Input Voltage (Note 3)	$\pm 30V$
Output Short Circuit Duration (Op Amp)	Continuous
Current from $V_{REF}$	10 mA
Voltage from Switch Collectors to GND	40V
Voltage from Switch Emitters to GND	40V
Voltage from Switch Collectors to Emitter	40V
Voltage from Power Diode to GND	40V
Reverse Power Diode Voltage	40V
Current through Power Switch	1.5A
Current through Power Diode	1.5A
ESD Susceptibility	(to be determined)

## LM78S40

### Electrical Characteristics

$T_A$  = Operating temperature range,  $V_{IN} = 5.0V$ ,  $V^+ (Op Amp) = 5.0V$ , unless otherwise specified. (Note 4)

Symbol	Parameter	Conditions	Min	Typ	Max	Units
<b>GENERAL CHARACTERISTICS</b>						
$I_{CC}$	Supply Current (Op Amp Disconnected)	$V_{IN} = 5.0V$		1.8	3.5	mA
		$V_{IN} = 40V$		2.3	5.0	mA
$I_{CC}$	Supply Current (Op Amp Connected)	$V_{IN} = 5.0V$			4.0	mA
		$V_{IN} = 40V$			5.5	mA
<b>REFERENCE SECTION</b>						
$V_{REF}$	Reference Voltage	$I_{REF} = 1.0 mA$ Extend $-55^\circ C < T_A < +125^\circ C$ , Comm $0 < T_A < +70^\circ C$ , Indus $-40^\circ C < T_A < +85^\circ C$	1.180	1.245	1.310	V
$V_{R LINE}$	Reference Voltage Line Regulation	$V_{IN} = 3.0V$ to $V_{IN} = 40V$ , $I_{REF} = 1.0 mA$ , $T_A = 25^\circ C$		0.04	0.2	mV/V
$V_{R LOAD}$	Reference Voltage Load Regulation	$I_{REF} = 1.0 mA$ to $I_{REF} = 10 mA$ , $T_A = 25^\circ C$		0.2	0.5	mV/mA
<b>OSCILLATOR SECTION</b>						
$I_{CHG}$	Charging Current	$V_{IN} = 5.0V$ , $T_A = 25^\circ C$	20		50	$\mu A$
$I_{CHG}$	Charging Current	$V_{IN} = 40V$ , $T_A = 25^\circ C$	20		70	$\mu A$
$I_{DISCHG}$	Discharge Current	$V_{IN} = 5.0V$ , $T_A = 25^\circ C$	150		250	$\mu A$
$I_{DISCHG}$	Discharge Current	$V_{IN} = 40V$ , $T_A = 25^\circ C$	150		350	$\mu A$
$V_{OSC}$	Oscillator Voltage Swing	$V_{IN} = 5.0V$ , $T_A = 25^\circ C$		0.5		V
$t_{on}/t_{off}$	Ratio of Charge/ Discharge Time			6.0		$\mu s/\mu s$

## LM78S40

### Electrical Characteristics (Continued)

$T_A$  = Operating Temperature Range,  $V_{IN}$  = 5.0V,  $V^+$  (Op Amp) = 5.0V, unless otherwise specified. (Note 4)

Symbol	Parameter	Conditions	Min	Typ	Max	Units
<b>CURRENT LIMIT SECTION</b>						
$V_{CLS}$	Current Limit Sense Voltage	$T_A = 25^\circ\text{C}$	250		350	mV
<b>OUTPUT SWITCH SECTION</b>						
$V_{SAT1}$	Output Saturation Voltage 1	$I_{SW} = 1.0\text{A}$ (Figure 1)		1.1	1.3	V
$V_{SAT2}$	Output Saturation Voltage 2	$I_{SW} = 1.0\text{A}$ (Figure 2)		0.45	0.7	V
$h_{FE}$	Output Transistor Current Gain	$I_C = 1.0\text{A}$ , $V_{CE} = 5.0\text{V}$ , $T_A = 25^\circ\text{C}$		70		
$I_L$	Output Leakage Current	$V_O = 40\text{V}$ , $T_A = 25^\circ\text{C}$		10		nA
<b>POWER DIODE</b>						
$V_{FD}$	Forward Voltage Drop	$I_D = 1.0\text{A}$		1.25	1.5	V
$I_{DR}$	Diode Leakage Current	$V_D = 40\text{V}$ , $T_A = 25^\circ\text{C}$		10		nA
<b>COMPARATOR</b>						
$V_{IO}$	Input Offset Voltage	$V_{CM} = V_{REF}$		1.5	15	mV
$I_{IB}$	Input Bias Current	$V_{CM} = V_{REF}$		35	200	nA
$I_{IO}$	Input Offset Current	$V_{CM} = V_{REF}$		5.0	75	nA
$V_{CM}$	Common Mode Voltage Range	$T_A = 25^\circ\text{C}$	0		$V_{IN} - 2$	V
PSRR	Power Supply Rejection Ratio	$V_{IN} = 3.0\text{V to } 40\text{V}$ , $T_A = 25^\circ\text{C}$	70	96		dB
<b>OPERATIONAL AMPLIFIER</b>						
$V_{IO}$	Input Offset Voltage	$V_{CM} = 2.5\text{V}$		4.0	15	mV
$I_{IB}$	Input Bias Current	$V_{CM} = 2.5\text{V}$		30	200	nA
$I_{IO}$	Input Offset Current	$V_{CM} = 2.5\text{V}$		5.0	75	nA
$A_{VS}^+$	Voltage Gain $^+$	$R_L = 2.0\text{ k}\Omega$ to GND; $V_O = 1.0\text{V to } 2.5\text{V}$ , $T_A = 25^\circ\text{C}$	25	250		V/mV
$A_{VS}^-$	Voltage Gain $-$	$R_L = 2.0\text{ k}\Omega$ to $V^+$ (Op Amp) $V_O = 1.0\text{V to } 2.5\text{V}$ , $T_A = 25^\circ\text{C}$	25	250		V/mV
$V_{CM}$	Common Mode Voltage Range	$T_A = 25^\circ\text{C}$	0		$V_{CC} - 2$	V
CMR	Common Mode Rejection	$V_{CM} = 0\text{V to } 3.0\text{V}$ , $T_A = 25^\circ\text{C}$	76	100		dB
PSRR	Power Supply Rejection Ratio	$V^+$ (Op Amp) = $3.0\text{V to } 40\text{V}$ , $T_A = 25^\circ\text{C}$	76	100		dB
$I_O^+$	Output Source Current	$T_A = 25^\circ\text{C}$	75	150		mA
$I_O^-$	Output Sink Current	$T_A = 25^\circ\text{C}$	10	35		mA
SR	Slew Rate	$T_A = 25^\circ\text{C}$		0.6		V/ $\mu\text{s}$
$V_{OL}$	Output Voltage LOW	$I_L = -5.0\text{ mA}$ , $T_A = 25^\circ\text{C}$			1.0	V
$V_{OH}$	Output Voltage High	$I_L = 50\text{ mA}$ , $T_A = 25^\circ\text{C}$	$V^+$ (Op Amp) - 3V			V

**Note 1:**  $T_{J\text{ Max}} = 150^\circ\text{C}$  for the Molded DIP, and  $175^\circ\text{C}$  for the Ceramic DIP.

**Note 2:** Ratings apply to ambient temperature at  $25^\circ\text{C}$ . Above this temperature, derate the 16L-Ceramic DIP at  $10\text{ mW}/^\circ\text{C}$ , and the 16L-Molded DIP at  $8.3\text{ mW}/^\circ\text{C}$ .

**Note 3:** For supply voltages less than 30V, the absolute maximum voltage is equal to the supply voltage.

**Note 4:** A military RETS specification is available on request. At the time of printing, the LM78S40 RETS specification complied with the Min and Max limits in this table. The LM78S40J may also be procured as a Standard Military Drawing.

## Typical Performance Characteristics

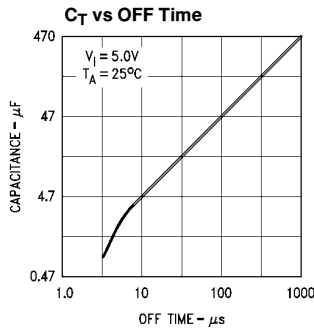

TL/H/10057-6

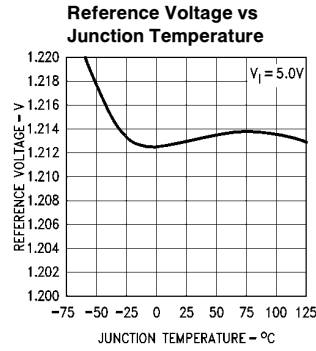

TL/H/10057-7

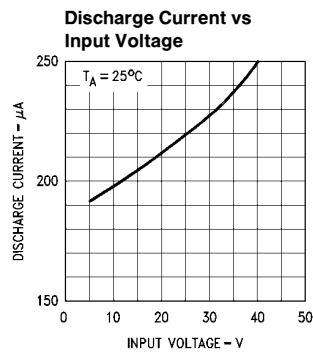

TL/H/10057-8

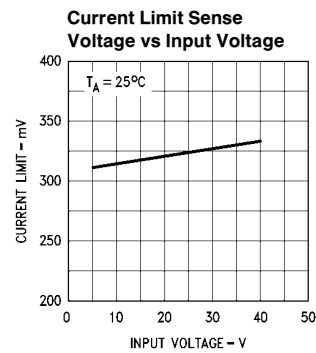

TL/H/10057-9

## Design Formulas

Characteristic	Step-Down	Step-Up	Inverting	Units
$\frac{t_{on}}{t_{off}}$	$\frac{V_O + V_D}{V_I - V_{SAT} - V_O}$	$\frac{V_O + V_D - V_I}{V_I - V_{SAT}}$	$\frac{ V_O  + V_D}{V_I - V_{SAT}}$	
$(t_{on} + t_{off}) \text{ Max}$	$\frac{1}{f_{Min}}$	$\frac{1}{f_{Min}}$	$\frac{1}{f_{MIN}}$	$\mu\text{s}$
$C_T$	$4 \times 10^{-5} t_{on}$	$4 \times 10^{-5} t_{on}$	$4 \times 10^{-5} t_{on}$	$\mu\text{F}$
$I_{pk}$	$2 I_{O \text{ Max}}$	$2 I_{O \text{ Max}} \cdot \frac{t_{on} + t_{off}}{t_{off}}$	$2 I_{O \text{ Max}} \cdot \frac{t_{on} + t_{off}}{t_{off}}$	A
$L_{Min}$	$\left( \frac{V_I - V_{SAT} - V_O}{I_{pk}} \right) t_{on \text{ Max}}$	$\left( \frac{V_I - V_{SAT}}{I_{pk}} \right) t_{on \text{ Max}}$	$\left( \frac{V_I - V_{SAT}}{I_{pk}} \right) t_{on \text{ Max}}$	$\mu\text{H}$
$R_{SC}$	$0.33 / I_{pk}$	$0.33 / I_{pk}$	$0.33 / I_{pk}$	$\Omega$
$C_O$	$\frac{I_{pk} (t_{on} + t_{off})}{8 V_{ripple}}$	$\approx \frac{I_O}{V_{ripple}} \cdot t_{on}$	$\approx \frac{I_O}{V_{ripple}} \cdot t_{on}$	$\mu\text{F}$

**Note:**  $V_{SAT}$  = Saturation voltage of the switching element.  
 $V_D$  = Forward voltage of the flyback diode.

## Functional Description

### SWITCHING FREQUENCY CONTROL

The LM78S40 is a variable frequency, variable duty cycle device. The initial switching frequency is set by the timing capacitor. (Oscillator frequency is set by a single external capacitor and may be varied over a range of 100 Hz to 100 kHz). The initial duty cycle is 6:1. This switching frequency and duty cycle can be modified by two mechanisms—the current limit circuitry ( $I_{pk}$  sense) and the comparator.

The comparator modifies the OFF time. When the output voltage is correct, the comparator output is in the HIGH state and has no effect on the circuit operation. If the output voltage is too high then the comparator output goes LOW. In the LOW state the comparator inhibits the turn-on of the output stage switching transistors. As long as the comparator is LOW the system is in OFF time. As the output current rises the OFF time decreases. As the output current nears its maximum the OFF time approaches its minimum value. The comparator can inhibit several ON cycles, one ON cycle or any portion of an ON cycle. Once the ON cycle has begun the comparator cannot inhibit until the beginning of the next ON cycle.

The current limit modifies the ON time. The current limit is activated when a 300 mV potential appears between lead 13 ( $V_{CC}$ ) and lead 14 ( $I_{pk}$ ). This potential is intended to result when designed for peak current flows through  $R_{SC}$ . When the peak current is reached the current limit is turned on. The current limit circuitry provides for a quick end to ON time and the immediate start of OFF time.

Generally the oscillator is free running but the current limit action tends to reset the timing cycle.

Increasing load results in more current limited ON time and less OFF time. The switching frequency increases with load current.

### USING THE INTERNAL REFERENCE, DIODE, AND SWITCH

The internal 1.245V reference (pin 8) must be bypassed, with 0.1  $\mu$ F directly to the ground pin (pin 11) of the LM78S40, to assure its stability.

$V_{FD}$  is the forward voltage drop across the internal power diode. It is listed on the data sheet as 1.25V typical, 1.5V maximum. If an external diode is used, then its own forward voltage drop must be used for  $V_{FD}$ .

$V_{SAT}$  is the voltage across the switch element (output transistors Q1 and Q2) when the switch is closed or ON. This is listed on the data sheet as Output Saturation Voltage.

“Output saturation voltage 1” is defined as the switching element voltage for Q2 and Q1 in the Darlington configuration with collectors tied together. This applies to *Figure 1*, the step down mode.

“Output saturation voltage 2” is the switching element voltage for Q1 only when used as a transistor switch. This applies to *Figure 2*, the step up mode.

For the inverting mode, *Figure 3*, the saturation voltage of the external transistor should be used for  $V_{SAT}$ .

## Typical Applications

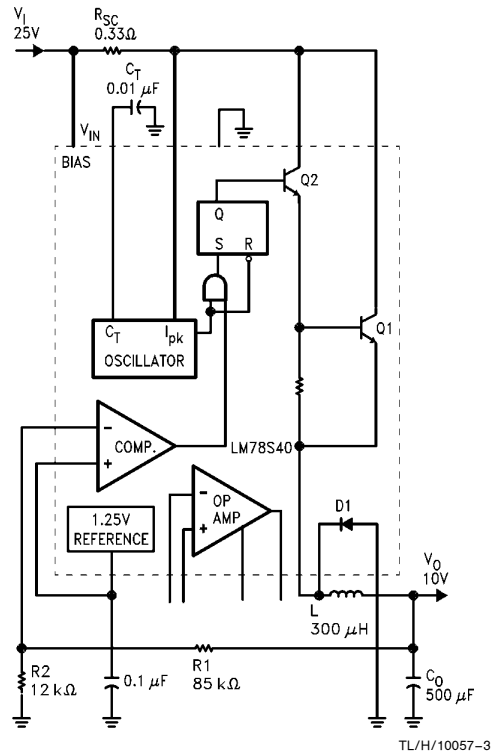

FIGURE 1. Typical Step-Down Regulator and Operational Performance ( $T_A = 25^\circ\text{C}$ )

Characteristic	Condition	Typical Value
Output Voltage	$I_O = 200 \text{ mA}$	10V
Line Regulation	$20\text{V} \leq V_I \leq 30\text{V}$	1.5 mV
Load Regulation	$5.0 \text{ mA} \leq I_O \leq 300 \text{ mA}$	3.0 mV
Max Output Current	$V_O = 9.5\text{V}$	500 mA
Output Ripple	$I_O = 200 \text{ mA}$	50 mV
Efficiency	$I_O = 200 \text{ mA}$	74%
Standby Current	$I_O = 200 \text{ mA}$	2.8 mA

**Note A:** For  $I_O \geq 200 \text{ mA}$  use external diode to limit on-chip power dissipation.

## Typical Applications (Continued)

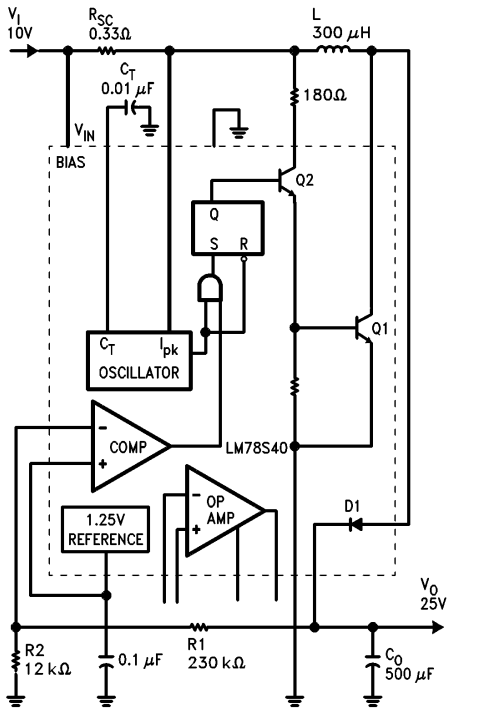

FIGURE 2. Typical Step-Up Regulator and Operational Performance ( $T_A = 25^\circ\text{C}$ )

TL/H/10057-4

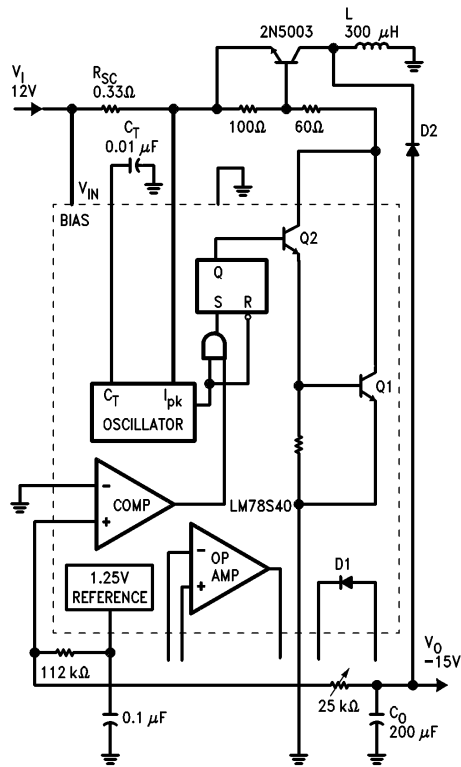

FIGURE 3. Typical Inverting Regulator and Operational Performance ( $T_A = 25^\circ\text{C}$ )

TL/H/10057-5

Characteristic	Condition	Typical Value
Output Voltage	$I_O = 50\text{ mA}$	25V
Line Regulation	$5.0\text{ V} \leq V_I \leq 15\text{ V}$	4.0 mV
Load Regulation	$5.0\text{ mA} \leq I_O \leq 100\text{ mA}$	2.0 mV
Max Output Current	$V_O = 23.75\text{ V}$	160 mA
Output Ripple	$I_O = 50\text{ mA}$	30 mV
Efficiency	$I_O = 50\text{ mA}$	79%
Standby Current	$I_O = 50\text{ mA}$	2.6 mA

Characteristic	Condition	Typical Value
Output Voltage	$I_O = 100\text{ mA}$	-15V
Line Regulation	$8.0\text{ V} \leq V_I \leq 18\text{ V}$	5.0 mV
Load Regulation	$5.0\text{ mA} \leq I_O \leq 150\text{ mA}$	3.0 mV
Max Output Current	$V_O = 14.25\text{ V}$	160 mA
Output Ripple	$I_O = 100\text{ mA}$	20 mV
Efficiency	$I_O = 100\text{ mA}$	70%
Standby Current	$I_O = 100\text{ mA}$	2.3 mA

## Typical Applications (Continued)

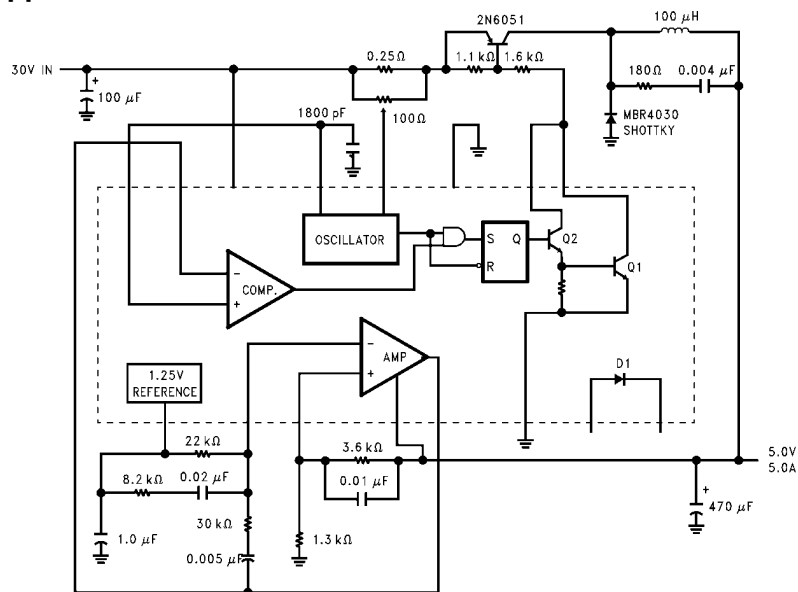
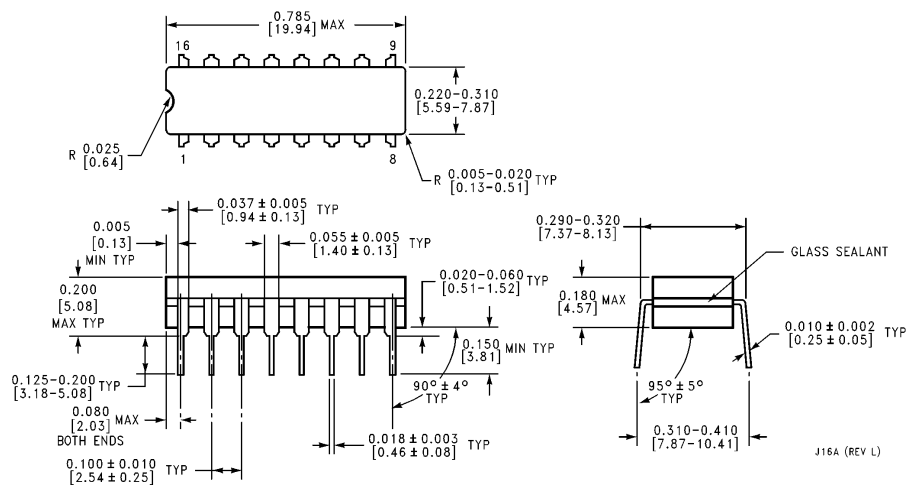

FIGURE 4. Pulse Width Modulated Step-Down Regulator ( $f_{osc} = 20 \text{ kHz}$ )

TL/H/10057-10

## Physical Dimensions inches (millimeters)



16-Lead Ceramic Dual-In-Line Package (J)  
Order Number LM78S40J/883  
NS Package Number J16A

J16A (REV L)

**Physical Dimensions** inches (millimeters) (Continued)

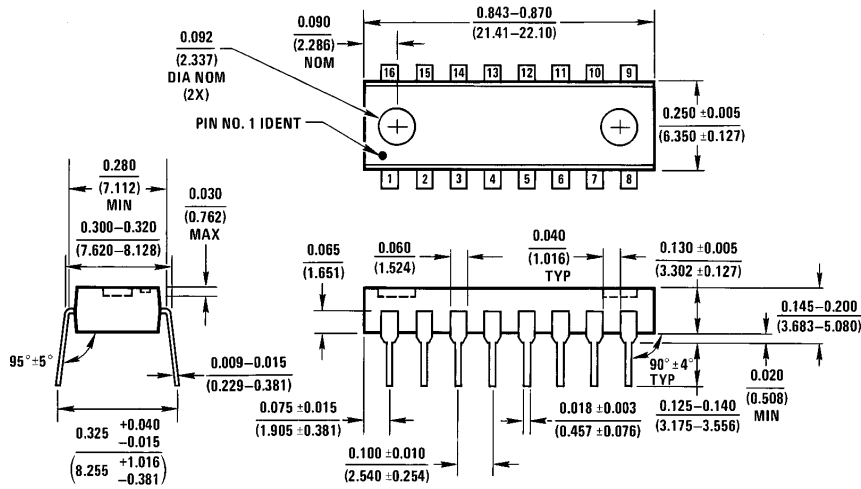

**16-Lead Molded Dual-In-Line Package (N)**  
**Order Number LM78S40N or LM78S40CN**  
**NS Package Number N16A**

N16A (REV E)

**LIFE SUPPORT POLICY**

NATIONAL'S PRODUCTS ARE NOT AUTHORIZED FOR USE AS CRITICAL COMPONENTS IN LIFE SUPPORT DEVICES OR SYSTEMS WITHOUT THE EXPRESS WRITTEN APPROVAL OF THE PRESIDENT OF NATIONAL SEMICONDUCTOR CORPORATION. As used herein:

1. Life support devices or systems are devices or systems which, (a) are intended for surgical implant into the body, or (b) support or sustain life, and whose failure to perform, when properly used in accordance with instructions for use provided in the labeling, can be reasonably expected to result in a significant injury to the user.
2. A critical component is any component of a life support device or system whose failure to perform can be reasonably expected to cause the failure of the life support device or system, or to affect its safety or effectiveness.



**National Semiconductor Corporation**  
 1111 West Bardin Road  
 Arlington, TX 76017  
 Tel: 1(800) 272-9959  
 Fax: 1(800) 737-7018

**National Semiconductor Europe**  
 Fax: (+49) 0-180-530 85 86  
 Email: cnjwge@tevm2.nsc.com  
 Deutsch Tel: (+49) 0-180-530 85 85  
 English Tel: (+49) 0-180-532 78 32  
 Français Tel: (+49) 0-180-532 93 58  
 Italiano Tel: (+49) 0-180-534 16 80

**National Semiconductor Hong Kong Ltd.**  
 19th Floor, Straight Block,  
 Ocean Centre, 5 Canton Rd.  
 Tsimshatsui, Kowloon  
 Hong Kong  
 Tel: (852) 2737-1600  
 Fax: (852) 2736-9960

**National Semiconductor Japan Ltd.**  
 Tel: 81-043-299-2309  
 Fax: 81-043-299-2408

National does not assume any responsibility for use of any circuitry described, no circuit patent licenses are implied and National reserves the right at any time without notice to change said circuitry and specifications.