

SANYO

No. 1571B

LB1649**Dual Bidirectional Motor Driver**

The LB1649 is a dual bidirectional motor driver. Since each channel has a 2-input logic circuit and performs bidirectional driving and braking functions, it is capable of direct driving 2pcs. of motor of various types rated at 6 to 24V. The output voltage can be varied by using external zener diodes. It is especially suited for dual motor drive (reel motor, loading motor, cassette motor in VTR) and for stepping motor drive.

Features

- . With power transistors for motor drive contained, capable of withstanding dash current of 1A max.
- . Performs braking function at the motor stop mode.
- . Contains elements to absorb motor dash current.
- . Input connectable direct to MOS LSI.
- . Minimum number of external parts required.
- . Wide operating voltage range.

Absolute Maximum Ratings at Ta=25°C			unit
Maximum Supply Voltage	V _{CCmax}	25	V
Input Voltage	V _{IN}	25	V
Output Current	I _O	±1	A
Allowable Power Dissipation	P _{dmax}	1.9	W
Operating Temperature	T _{opr}	-25 to +75	°C
Storage Temperature	T _{stg}	-55 to +125	°C

Allowable Operating Conditions at Ta=25°C			unit
Supply Voltage	V _{CC}	7 to 25	V

Electrical Characteristics at Ta=25°C, V _{CC} =12V, per channel				min	typ	max	unit
Current Dissipation	I _{CC}	Braking mode, R _L =∞ per channel		7.0	10.0		mA
Output Leakage Current	I _{OL}	Braking mode, R _L =∞ per channel		40	120		μA
Input Threshold Voltage	V _{th}	R _L =∞	0.9	1.05	1.20		V
Output Voltage	V _O	R _L =60ohms, V _Z =7.4V	6.5	7.2	7.5		V

Continued on next page.

Package Dimensions 3022A

(unit: mm)

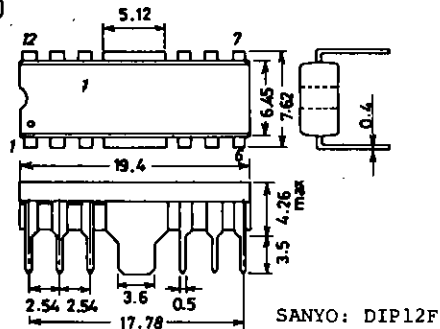

SANYO Electric Co., Ltd. Semiconductor Business Headquarters
 TOKYO OFFICE Tokyo Bldg., 1-10, 1 Chome, Ueno, Taito-ku, TOKYO, 110 JAPAN

N3093TS/9047KI/9074KI, TS No.1571-1/5

Continued from preceding page.

			min	typ	max	unit
Output Tr Saturation Voltage (Upper)	V_{sat1}	$I_{OUT}=300mA$		1.9	2.3	V
		$I_{OUT}=500mA$		2.0	2.4	V
Output Tr Saturation Voltage (Lower)	V_{sat2}	$I_{OUT}=300mA$	0.3	0.55		V
		$I_{OUT}=500mA$	0.5	0.7		V

Test Circuits (per channel)

(1) I_{CC}

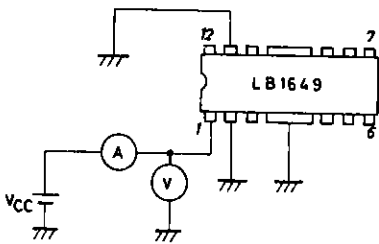

(2) I_{OL}

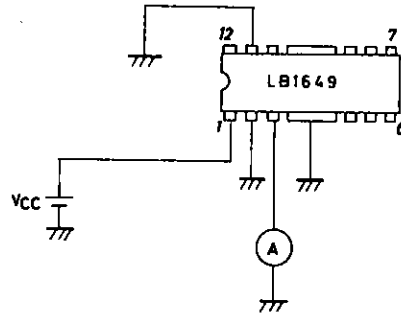

(3) V_{th}

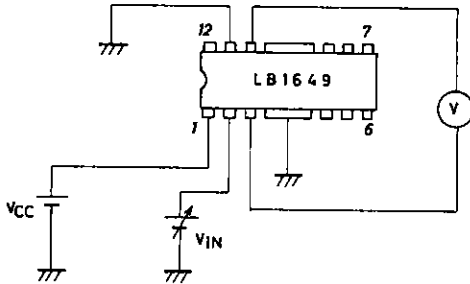

(4) V_O

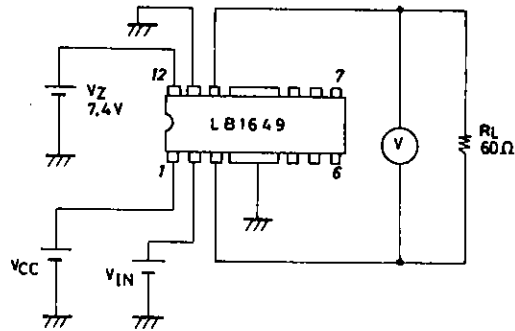

(5) V_{sat1}

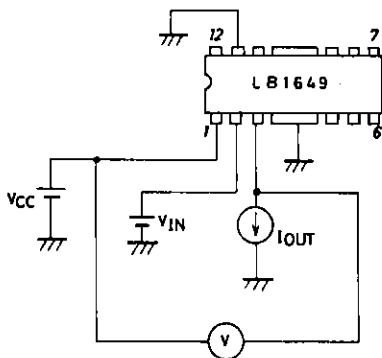

(6) V_{sat2}

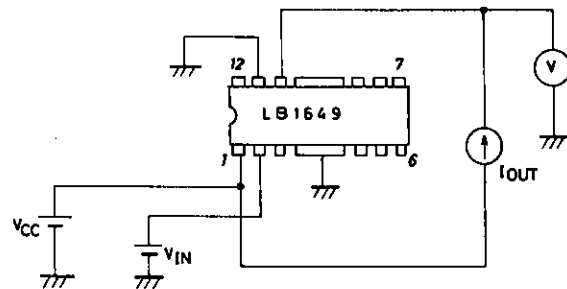

Equivalent Circuit Block Diagram

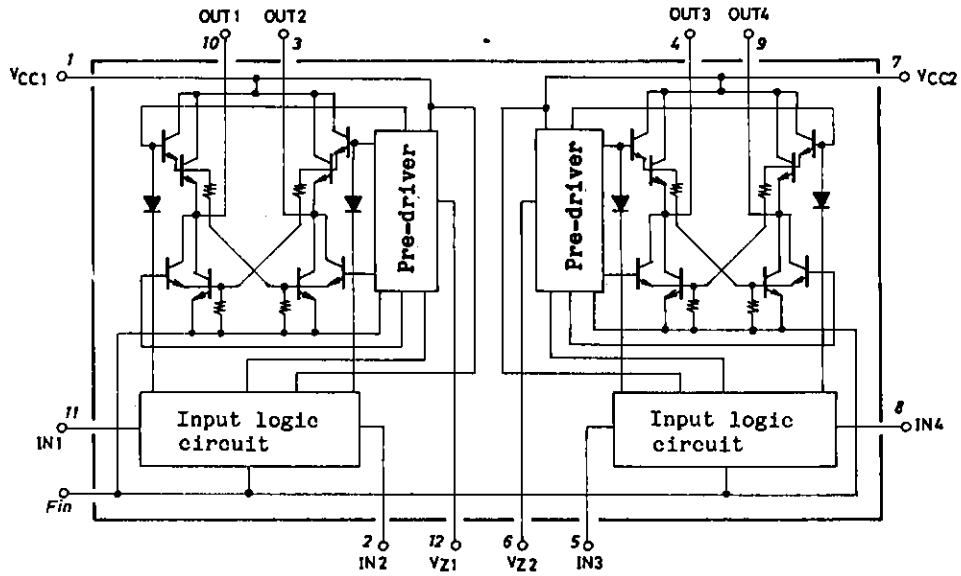

Truth Table of Logic Circuit

IN1	IN2	OUT1	OUT2	IN3	IN4	OUT3	OUT4
0	0	L	L	0	0	L	L
1	0	H	L	1	0	H	L
0	1	L	H	0	1	L	H
1	1	L	L	1	1	L	L

Note) A capacitor of 0.01 μ F or greater must be connected across V_{CC}1,2 and GND.

INPUT			OUT PUT				MODE	
IN1	IN2,3	IN4	OUT1	OUT2	OUT3	OUT4	M1	M2
0	0	0	L	L	L	L	Brake	Brake
1	0	0	H	L	L	L	Forward/Reverse	Brake
0	1	1	L	H	L	L	Reverse/Forward	Brake
1	1	0	L	L	H	L	Brake	Forward/Reverse
0	0	1	L	L	L	H	Brake	Reverse/Forward
1	1	1	L	L	L	L	Brake	Brake

The remaining input states 1,0,1 and 0,1,0 are not inhibited.

Sample Application Circuit

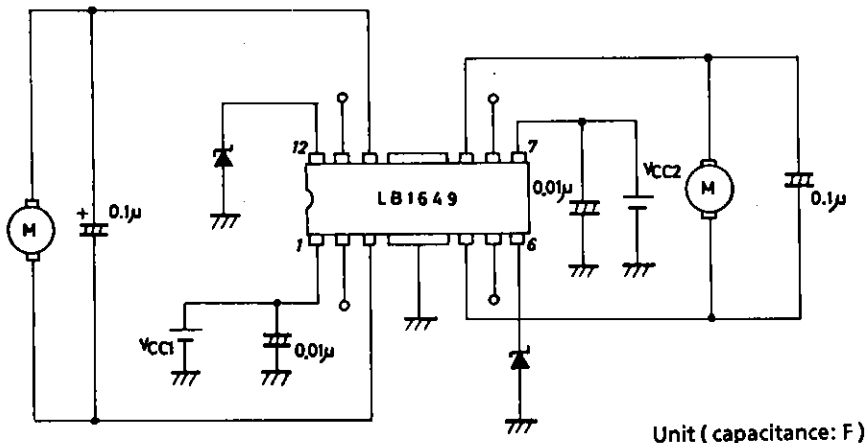

Input Circuit

The input circuit is shown right.

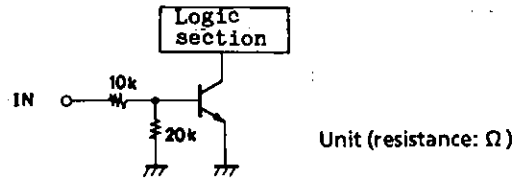

V_Z pin

Zener voltage	V_Z pin Voltage value
$\geq 5.6V$	small
$< 5.6V$	large*

*Susceptible to V_Z pin flow-out current change.

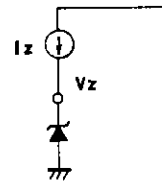

I_Z --- V_Z flow-out current

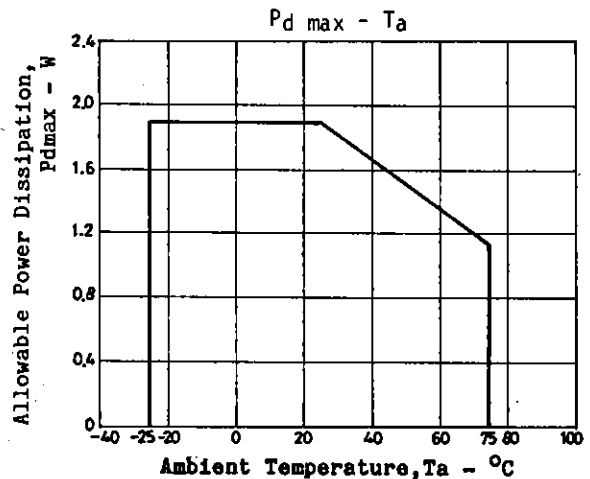
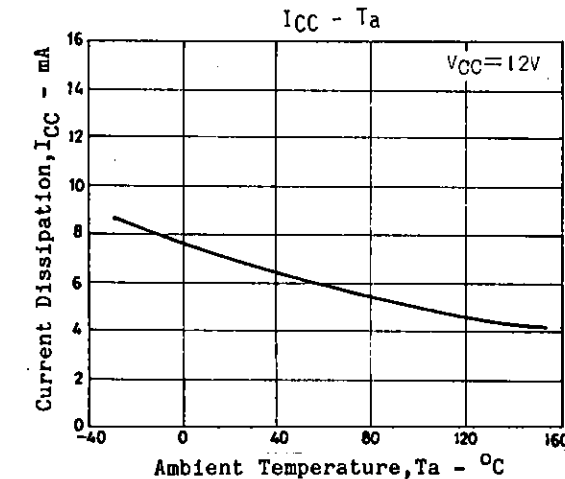
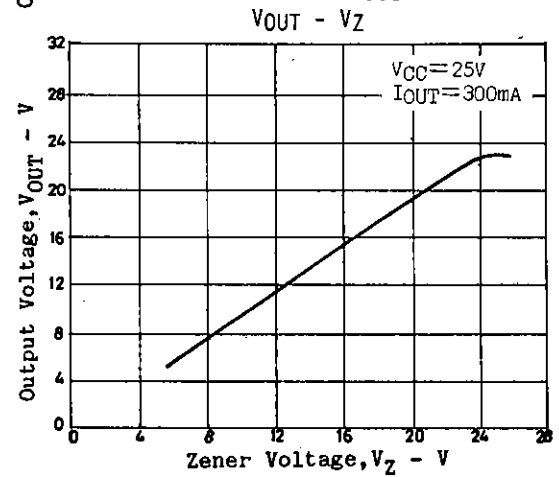
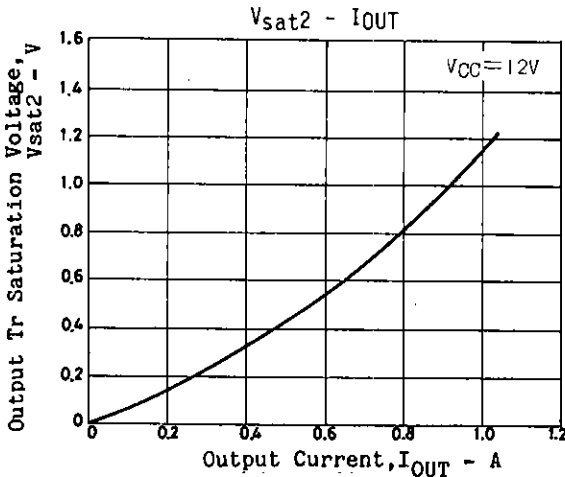
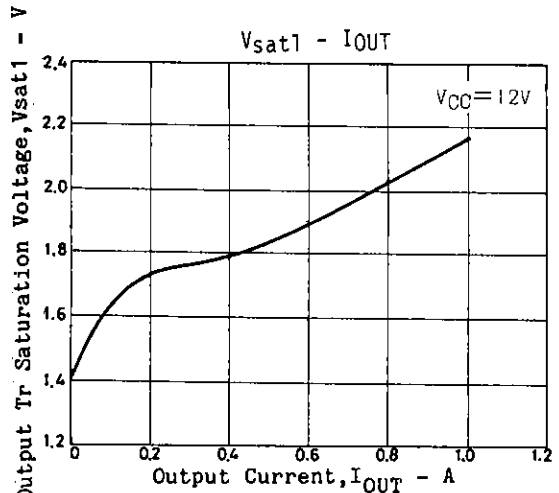
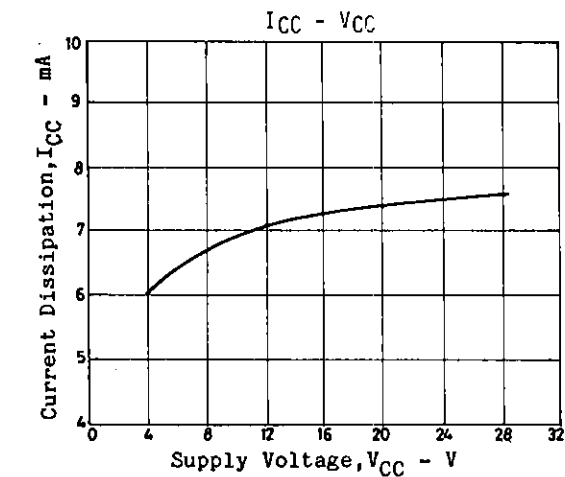

- No products described or contained herein are intended for use in surgical implants, life-support systems, aerospace equipment, nuclear power control systems, vehicles, disaster/crime-prevention equipment and the like, the failure of which may directly or indirectly cause injury, death or property loss.
- Anyone purchasing any products described or contained herein for an above-mentioned use shall:
 - ① Accept full responsibility and indemnify and defend SANYO ELECTRIC CO., LTD., its affiliates, subsidiaries and distributors and all their officers and employees, jointly and severally, against any and all claims and litigation and all damages, cost and expenses associated with such use:
 - ② Not impose any responsibility for any fault or negligence which may be cited in any such claim or litigation on SANYO ELECTRIC CO., LTD., its affiliates, subsidiaries and distributors or any of their officers and employees jointly or severally.
- Information (including circuit diagrams and circuit parameters) herein is for example only; it is not guaranteed for volume production. SANYO believes information herein is accurate and reliable, but no guarantees are made or implied regarding its use or any infringements of intellectual property rights or other rights of third parties.