

SANYO

No. 4469A

LA4805V**3 V Stereo Headphone Power Amplifier****Overview**

The LA4805V is a power IC developed for use in stereo headphones. It includes low frequency enhancement, beep function and output control circuits on-chip. Furthermore, the LA4805V realizes a high S/N ratio, a high ripple exclusion ratio, and low current drain.

Functions

- Stereo headphone power amplifier
- Low frequency enhancement (L.BOOST)
- Beep amplifier
- Output suppression circuit (PVSS)
- Power switch
- Muting switch

Features

- Low current drain (8.3 mA typical)
- High S/N ratio (90 dB typical, 13 μ V)
- High ripple exclusion ratio (75 dB typical)
- No output electrolytic capacitors required
- Ultra-miniature package (SSOP-30)

Specifications**Maximum Ratings at Ta = 25°C**

Parameter	Symbol	Condition	Rating	Unit
Maximum supply voltage	$V_{CC\ max}$		4.5	V
Allowable power dissipation	$Pd\ max$		500	mW
Operating temperature	T_{opr}		-15 to +50	°C
Storage temperature	T_{stg}		-40 to +150	°C

Operating Conditions at Ta = 25°C

Parameter	Symbol	Condition	Rating	Unit
Recommended supply voltage	V_{CC}		3.0	V
Recommended load resistance	R_L		16 to 32	Ω
Operating supply voltage range	$V_{CC\ op}$		1.8 to 3.6	V

Package Dimensions

unit: mm

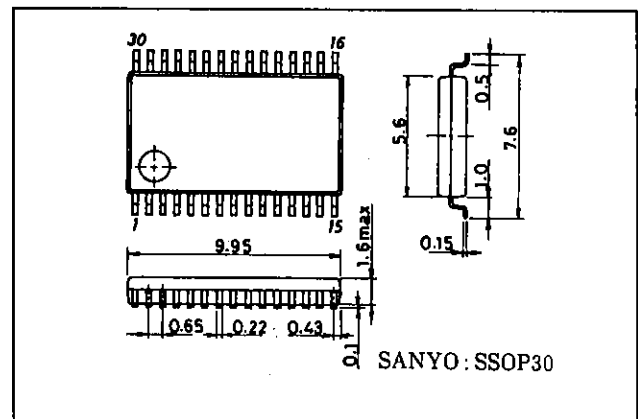
3191-SSOP30

LA4805V

Operating Characteristics

at $T_a = 25^\circ\text{C}$, $V_{CC} = 3.0\text{ V}$, $f = 1\text{ kHz}$, $0.775\text{ V} = 0\text{ dBm}$, $R_L = 10\text{ k}\Omega$ (L.B), $R_L = 16\ \Omega$ (PWR)

Parameter	Symbol	Condition	Rating			Unit
			min	typ	max	
[L.BOOST + PVSS + PWR]						
Quiescent current	I _{CCO1}	IC off		0.05	1.0	μA
	I _{CCO2}	Muting on	1.0	2.7	5.0	mA
	I _{CCO3}	R _g = 0, L.BST/PVSS off	4.0	8.3	12.0	mA
	I _{CCO4}	R _g = 0, L.BST/PVSS on	4.5	8.6	12.5	mA
[PWR AMP]						
Output power	P _O	THD = 10%	15	25		mW
Voltage gain	VG1	V _O = -10 dBm	15.7	17.7	19.7	dB
Channel balance	V _{BL}	V _O = -10 dBm	-1	0	1	dB
Total harmonic distortion	THD1	V _O = 0.35 V		0.1	0.3	%
Output noise voltage	V _{NO1}	R _g = 0, D _{IN} AUDIO		13	25	μV
Crosstalk	CT1	V _O = -10 dBm, TUN = 1 kHz, R _g = 0	35	45		dB
Ripple exclusion ratio	SVRR1	V _{CC} = 1.8 V, f = 100 Hz, V _R = -20 dBm, TUN = 100 Hz	60	75		dB
Muting attenuation	ATT _M	THD = 1%, R _g = 0 k Ω	80	90		dB
Beep output	V _O BEEP	V _{IN} = -16 dBm (sine wave)	1.0	3.0		mV
Output current offset	V _{DC} OFF	V _{IN} = 0 V, R _g = 0	-20	0	20	mV
Input resistance	R _i		7	10	13	k Ω
[L.BOOST]						
Voltage gain	VG2	V _{IN} = -30 dBm, boost on/off	-3.2	-5.2	-7.2	dB
Boost*	L.BTS1	V _{IN} = -30 dBm, f = 100 Hz, boost on	13	15	17	dB
	L.BTS2	V _{IN} = -30 dBm, f = 10 kHz, boost on	3	5	7	dB
Maximum output voltage	V _O max	THD = 1%, boost on	0.2	0.4	0.6	V
Total harmonic distortion	THD2	V _O = 0.1 V, boost on		0.085	0.25	%
Crosstalk	CT2	V _O = -20 dBm, R _g = 0, boost on	25	30		dB
Output noise voltage	V _{NO2}	R _g = 0, boost off		3	10	μV
Ripple exclusion ratio	SVRR2	R _g = 0, f = 100 Hz, V _g = -20 dBm, boost on	50	60		dB
[L.BOOST + PWR]						
Voltage gain	VG3	V _{IN} = -30 dBm, f = 1 kHz, boost on/off	8	10	12	dB
Output voltage	V _{O1}	V _{IN} = -30 dBm, f = 100 Hz, boost on	0.13	0.23	0.33	V
Total harmonic distortion	THD3	V _{IN} = -30 dBm, f = 100 Hz, boost on		0.14	0.5	%
Crosstalk	CT3	V _O = -20 dBm, R _v = 0 Ω , boost on	25	32.5		dB
[L.BOOST + PVSS + PWR]: When V _{O1} is maximum						
PVSS voltage	V _O PVSS2	V _{IN} = -30 dBm, PVSS2	-32.5	-37.5	-42.5	dBm
PVSS width	V _O PVSS W	The input amplitude when the output is +3 dB over the starting point	25	30	35	dB
PVSS distortion	THD PVSS	V _{IN} = -40 dBm, PVSS2		0.55	2.0	%
PVSS starting input	V _{IN} PVSS	PVSS2	-41	-46	-51	dBm

Note: * Boost levels relative to 1 kHz

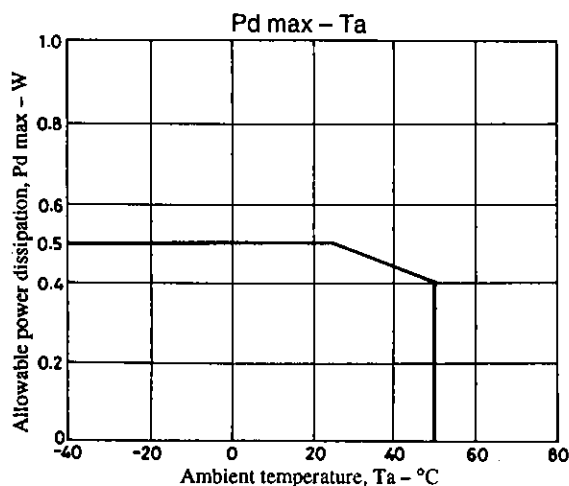

Pin Assignment and Block Diagram

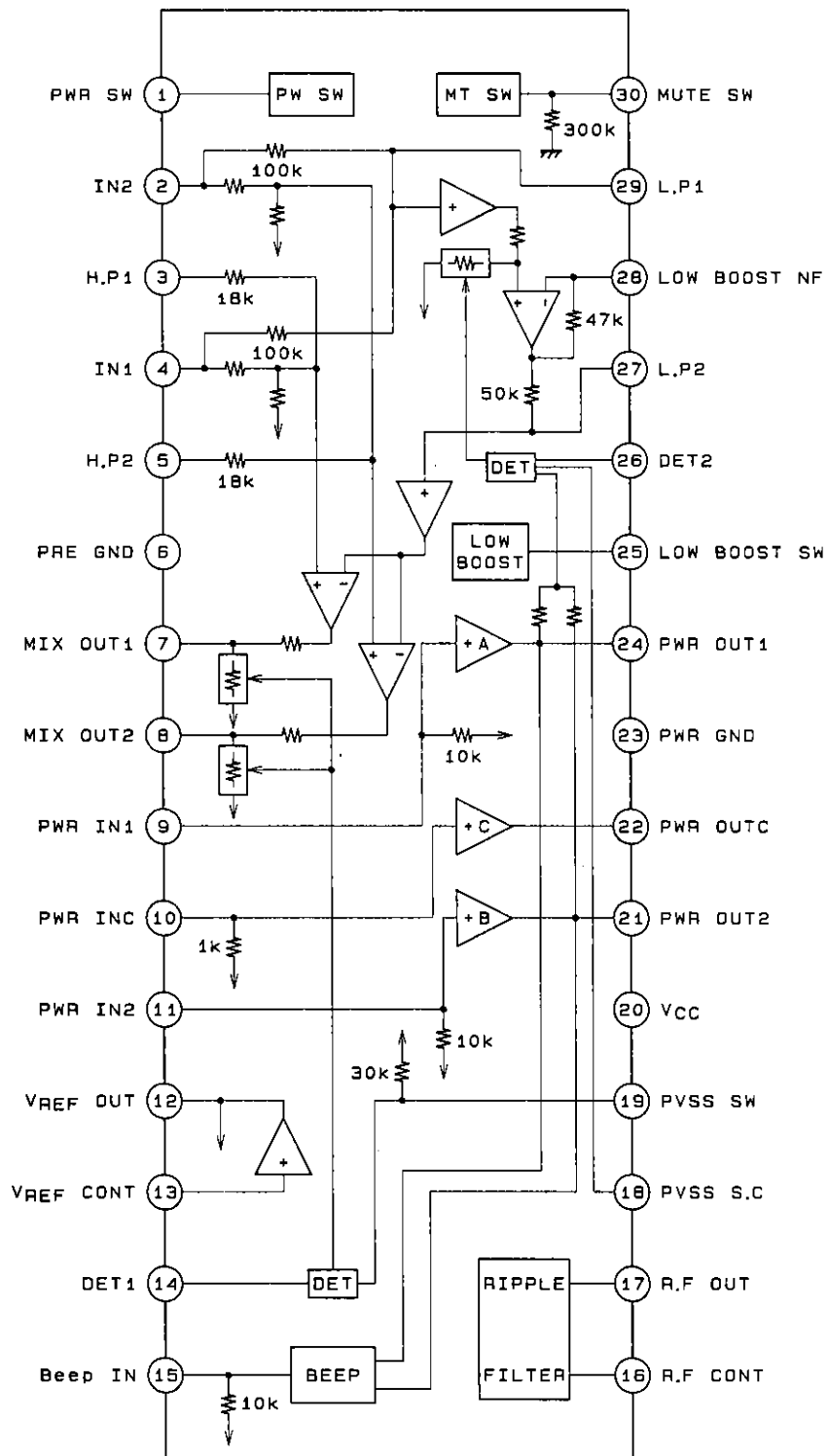

A01329

Unit (resistance: Ω)

Test Circuit

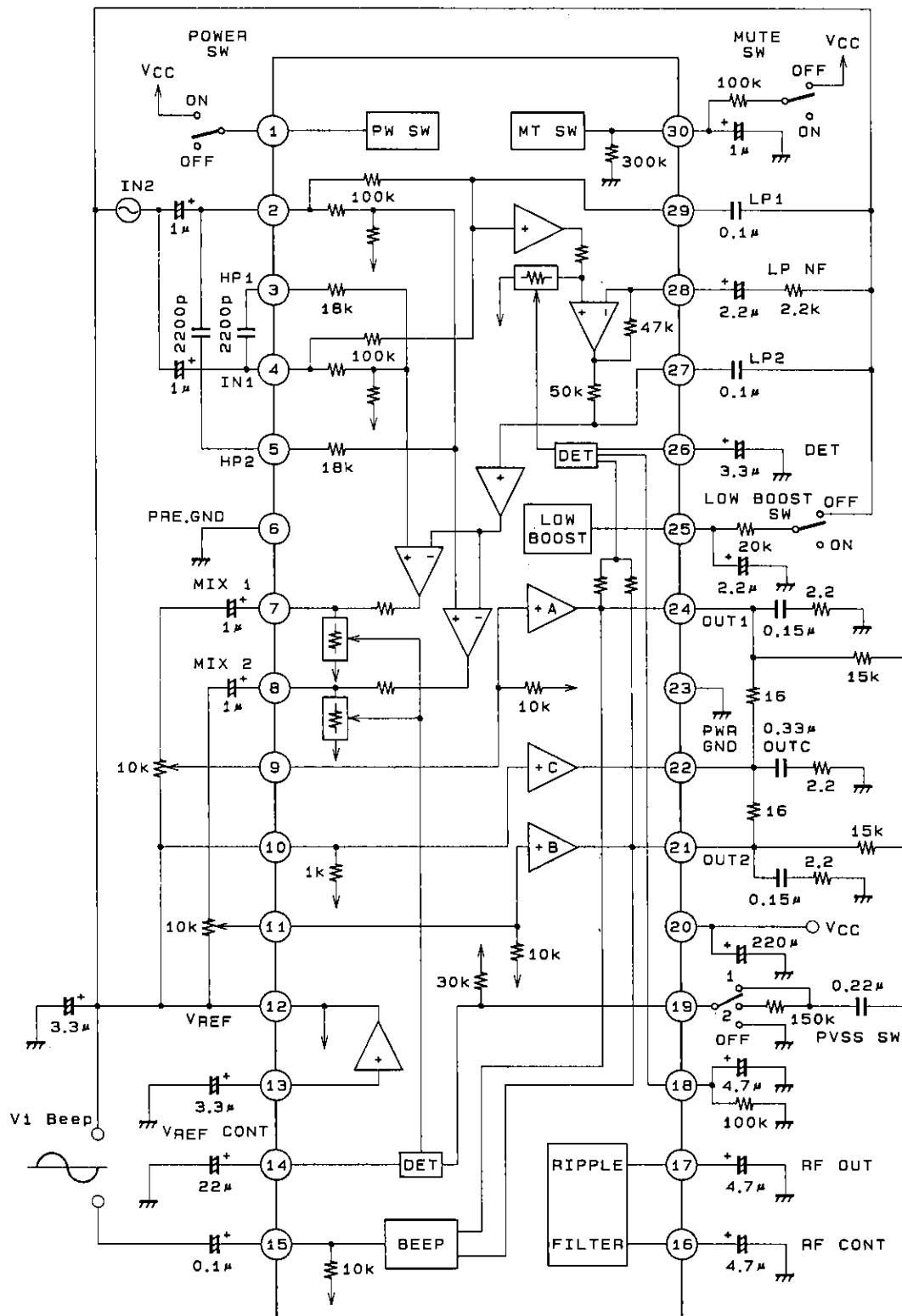

A01330

Unit (resistance: Ω, capacitance: F)

Application Circuit

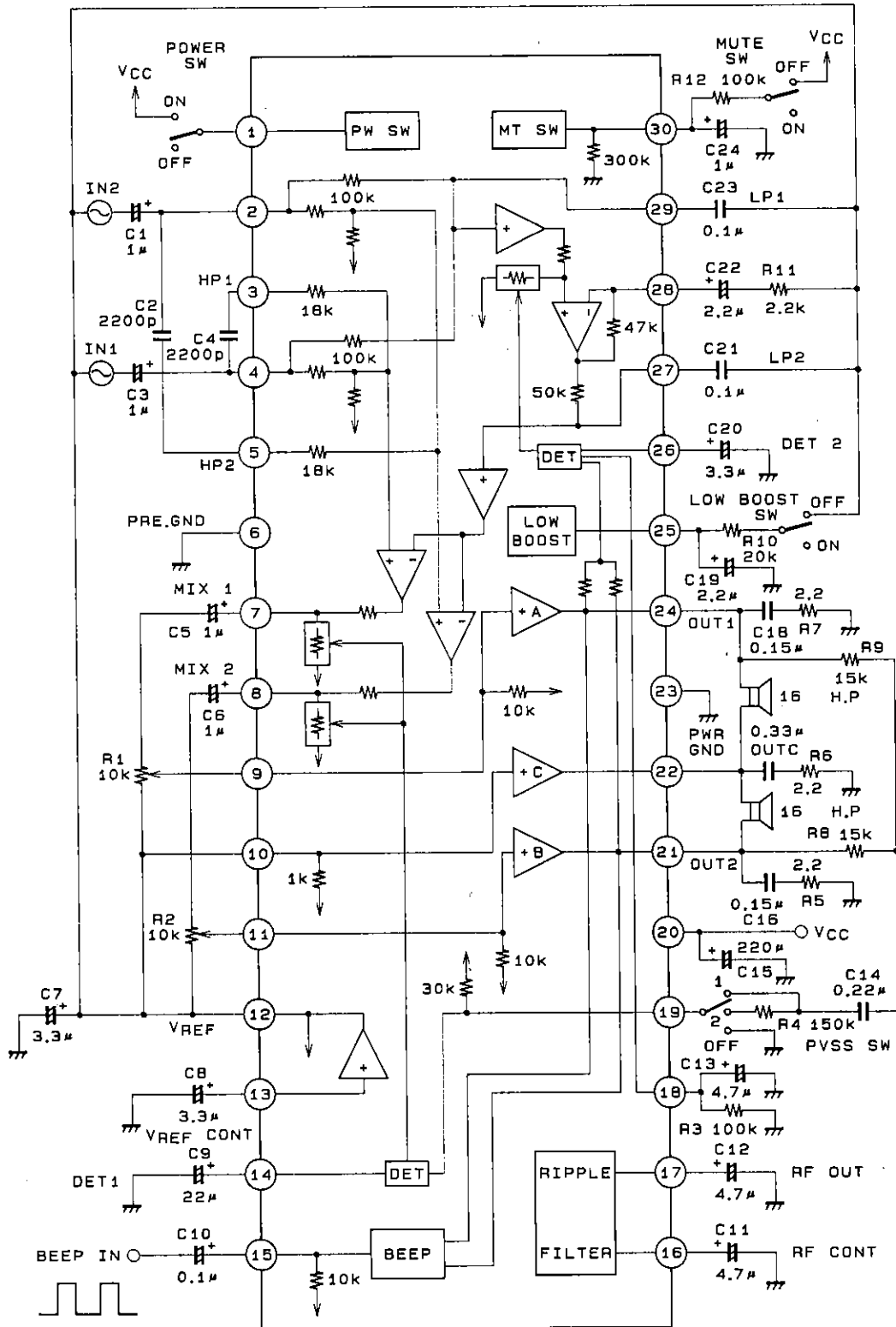

A01331

Unit (resistance: Ω , capacitance: F)

LA4805V

Pin Functions and Equivalent Circuits ($V_{CC} = 3.0\text{ V}$)

Unit (resistance: Ω)

Pin No.	Symbol	V_{DC} (V)	Equivalent circuit	Pin function
1	PWR SW	0 to 0.7	<p>A01332</p>	<ul style="list-style-type: none"> Applying V_{CC} to pin 1 turns the IC power on.
2 4	IN 2 IN 1	1.1 1.1	<p>A01333</p>	<ul style="list-style-type: none"> Low boost input pin
3 5	H.P 1 H.P 2	1.1 1.1	<p>A01334</p>	<ul style="list-style-type: none"> High-pass input pin
6	PRE GND			
7 8	MIX OUT 1 MIX OUT 2	1.1 1.1	<p>A01335</p>	<ul style="list-style-type: none"> Low boost and buffer output pin
9 11	PWR IN 1 PWR IN 2	1.1 1.1	<p>A01336</p>	<ul style="list-style-type: none"> Power input pin The input resistance is 10 kΩ.
10	PWR IN C	1.1	<p>A01337</p>	<ul style="list-style-type: none"> Power amp common input pin Connect to V_{ref} in normal operation

Continued on next page.

LA4805V

Continued from preceding page.

Unit (resistance: Ω , capacitance: F)

Pin No.	Symbol	V _{DC} (V)	Equivalent circuit	Pin function
12	V _{REF} OUT	1.1	<p style="text-align: right;">A01338</p>	<ul style="list-style-type: none"> • Fixed bias of 1.1 V
13	V _{REF} CONT	1.1	<p style="text-align: right;">A01339</p>	<ul style="list-style-type: none"> • The V_{REF} CONT pin, 1.1 V
14	DET 1	0 to 1.3	<p style="text-align: right;">A01340</p>	<ul style="list-style-type: none"> • AVLS operates at 0.65 V or higher.
15	Beep IN	1.1	<p style="text-align: right;">A01341</p>	<ul style="list-style-type: none"> • Beep input pin • Only operates when the muting function is on.
16	R.F. CONT	2.2	<p style="text-align: right;">A01342</p>	<ul style="list-style-type: none"> • The R.F. CONT pin
17	R.F. OUT	2.65	<p style="text-align: right;">A01343</p>	<ul style="list-style-type: none"> • Set to a bias of about 0.88 times V_{CC}.

Continued on next page.

LA4805V

Continued from preceding page.

Unit (resistance: Ω , capacitance: F)

Pin No.	Symbol	V _{DC} (V)	Equivalent circuit	Pin function
18	PVSS S.C	0 to 0.7	<p style="text-align: right;">A01344</p>	<ul style="list-style-type: none"> Smoothing pin used when PVSS is turned on and off.
19	PVSS SW	0 to 1.1	<p style="text-align: right;">A01345</p>	<ul style="list-style-type: none"> PVSS is turned on by the power output signal, and turned off when grounded.
20	V _{CC}			
21 22 24	PWR OUT 2 PWR OUT C PWR OUT 1	1.1 1.1 1.1	<p style="text-align: right;">A01346</p>	<ul style="list-style-type: none"> The power output pins The LA4805V drives headphones with pin 22 used as a common center. (No electrolytic capacitors are used in the output.)
23	PWR GND			
25	LOW BOOST SW	0 to 1.0	<p style="text-align: right;">A01347</p>	<ul style="list-style-type: none"> The low boost function is turned on when this pin is floating and turned off when it is connected to V_{ref}.
26	DET 2	0.5 to 1.3	<p style="text-align: right;">A01348</p>	<ul style="list-style-type: none"> ALC operates at 0.65 V or higher.
27	L.P 2	1.1	<p style="text-align: right;">A01349</p>	<ul style="list-style-type: none"> Low boost secondary low pass pin

Continued on next page.

Continued from preceding page.

Unit (resistance: Ω)

Pin No.	Symbol	V _{DC} (V)	Equivalent circuit	Pin function
28	LOW BOOST NF	1.1		• Low boost NF pin
29	LP 1	1.1		• Low boost primary low pass pin
30	MUTE SW	0 to 2.2		• The muting function is on when this pin is floating and off when connected to V _{CC} through a 100 k Ω resistor.

External Component Functions: Recommended values are indicated in parentheses.

- C1, C3 (1 to 4.7 μ F)

Input coupling capacitors

- C2, C4 (2200 pF)

Input high pass capacitors. The high region gain when low boost is on is determined by the IC internal 18 k Ω resistance and these external 2200 pF capacitors.

- C5, C6 (0.1 to 1 μ F)

Mixer amplifier to power amplifier coupling capacitors

- C7, C8 (3.3 to 10 μ F)

Reference bias (V_{ref}) decoupling capacitors

- C9 (10 to 22 μ F)

Determines the PVSS recovery time.

- C10 (0.1 to 1 μ F)

Beep input coupling capacitor. Be sure that this capacitor does not attenuate the beep signal.

- C11, C12 (4.7 to 10 μ F)

Ripple filter capacitors. Care is required selecting their value, since although increasing the capacitance increases the ripple exclusion ratio, it also increases the rise time when the power is turned on.

- C13 (3.3 to 4.7 μ F)

Smoothing capacitor for PVSS on/off switching noise

- C14 (0.22 to 0.47 μF)

Coupling capacitor that accepts the power output signal and inputs that signal to the PVSS function.

- C15 (220 μF)

Power supply line decoupling capacitor

- C16, C17, C18 (0.22 to 0.47 μF)

Oscillation suppression capacitors. We recommend using film capacitors.

- C19 (2.2 to 4.7 μF)

Smoothing capacitor for low boost on/off switching noise

- C20 (3.3 to 4.7 μF)

Determines the low boost attack time. Increasing the capacitance increases the attack time.

- C21, C23 (0.1 μF)

Low pass capacitors used with the low boost function

- C22 (2.2 to 4.7 μF)

Low boost amplifier NF capacitor. Values in excess of the recommended range will slow the low boost amplifier's rise time and may cause noise spikes.

- C24 (0.1 to 1.0 μF)

Determines the muting time. See the "IC Usage Notes" section for a discussion of the muting time when the capacitor C24 value is varied.

- R1, R2 (10 $\text{k}\Omega$)

Mixer amplifier load resistance and power input adjustment potentiometer.

- R3 (100 k to 1 $\text{M}\Omega$)

Smoothing resistor for PVSS on/off switching noise

- R4 (50 k to 200 $\text{k}\Omega$)

PVSS level adjustment resistor

- R5, R6, R7 (1 to 4.3 Ω)

Power amplifier oscillation suppression capacitors. We recommend using film capacitors.

- R8, R9 (15 $\text{k}\Omega$)

Power output signal bias resistor for PVSS operation

- R10 (20 $\text{k}\Omega$)

Determines the pin 25 bias when low boost is off.

- R11 (1.5 k to 2.2 $\text{k}\Omega$)

Determines the low boost amplifier's voltage gain.

- R12 (100 $\text{k}\Omega$)

Determines the pin 30 bias when muting is off (and PWR is on).

We recommend using a 100 $\text{k}\Omega$ resistor for R12, since the muting switch pin (pin 30) threshold area is determined by this (100 $\text{k}\Omega$) resistance and the IC's internal 300 $\text{k}\Omega$ resistance.

Usage Notes and Operating Principles

1. Beep function operating principles

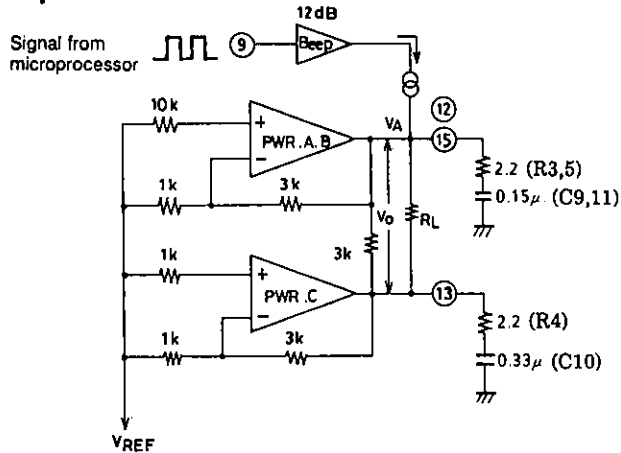

Unit (resistance: Ω, capacitance: F)

- The figure above shows the beep function block, which is designed to operate when muting is on, i.e., when pin 16 is open.

The output voltage generated at R_L at that time is given by the following equation.

$$V_O = \frac{R_L}{R_L + 3\text{ k} + 1\text{ k}} \times V_A$$

For example, when R_L is $16\ \Omega$ and V_A is 0.5 V : (V_A is adjusted by the pin 9 input level.)

$$V_O = \frac{16\ \Omega}{16\ \Omega + 3\text{ k} + 1\text{ k}} \times 0.5\text{ V} \approx 2\text{ mV}$$

- While the beep output V_O is determined by the formula above, it is influenced by the capacitor and resistor used to form the PWR output oscillation suppression function. Therefore, when using the beep function, it is necessary to make the impedance due to the pin 13 capacitor C10 smaller than the impedance of capacitors C9 and C10 on pins 12 and 15, since pin 13 is a common output. Which is to say, the capacitor C10 must be larger than the capacitors C9 and C10.

2. Muting time

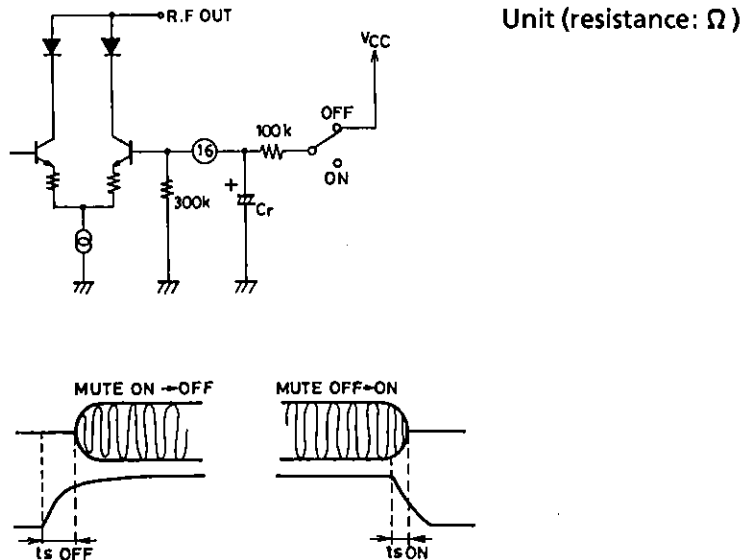

Unit (resistance: Ω)

- The figure above shows the waveform when the muting function is turned on and off. The t_s on and off times here can be changed by the capacitor C_r on pin 16. While the recommended value for C_r is $1\ \mu\text{F}$, note that reducing this value can lead to increased impulse (“pop”) noise.

LA4805V

- The table below lists the $t_{s\ OFF}$ and $t_{s\ ON}$ for different values of C_r .

C_r	$t_{s\ OFF}$	$t_{s\ ON}$
0.1 μF	15 ms	3.2 ms
1.0 μF	150 ms	30 ms
2.2 μF	300 ms	56 ms

3. Boost level when the low boost function and PVSS are on

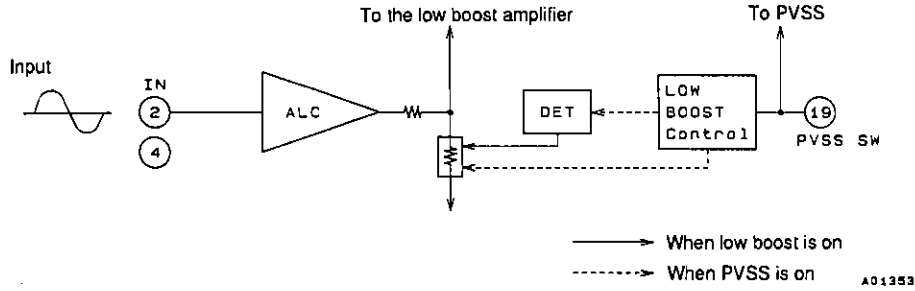

- Normally, the 100 Hz boost level with respect to 1 kHz is 15 dB when low boost is on. However, the LA4805V is designed so that the 100 Hz boost level with respect to 1 kHz is 9 dB when both PVSS and low boost are on. PVSS is turned on when the power output is input to pin 19, and the low boost level is determined by adjusting the DET as shown by the dotted lines in the figure. (See the separately provided detailed data describing the state where both low boost and PVSS are on.)

- The graphs below give a simplified view of the f_i -VG characteristics.

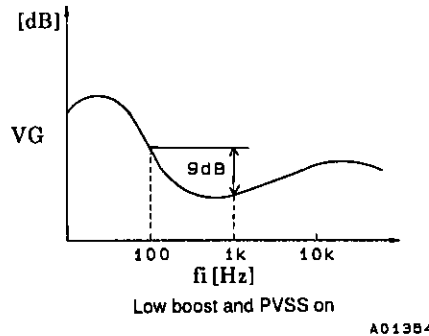
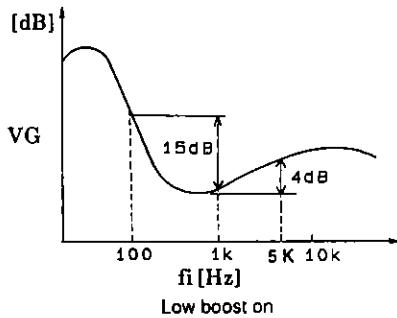

4. PVSS

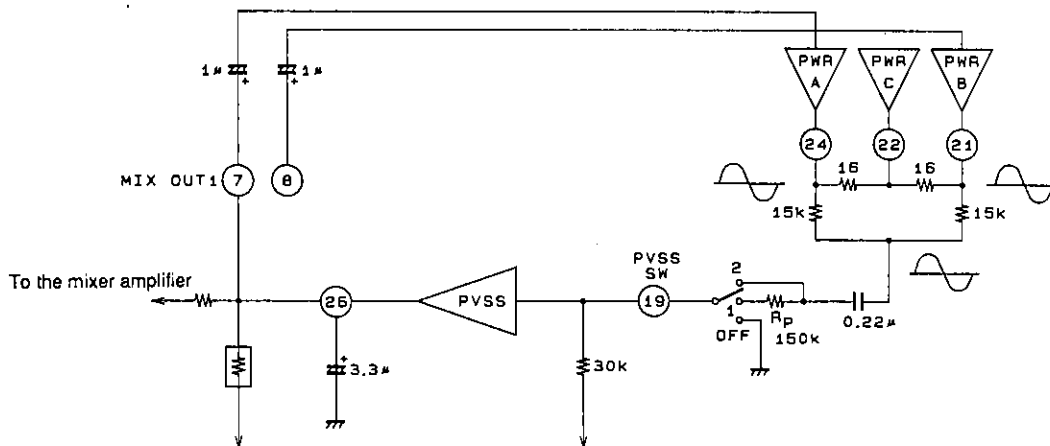

Unit (resistance: Ω , capacitance: F)

- As shown in the figure above, PVSS is designed so that PVSS is operated and turned on by inputting to pin 19 the mixed power outputs through 15 kΩ resistors. When this input is grounded, PVSS is turned off.
- PVSS switching can be changed by an IC internal 30 kΩ resistor and an external (150 kΩ) resistor. When this function is used, V_O is set to 45 mV by passing the mixed signal through a 150 kΩ resistor at PVSS1, and is set to 10 mV by passing the mixed signal through only the 0.22 μF capacitor at PVSS2. (Detailed data is provided separately.)
- The graph below gives a simplified view of the V_i - V_O characteristics and the output V_O when R_P is varied.

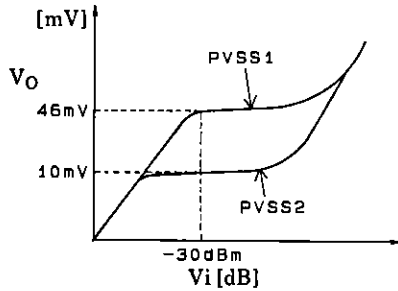

R_P	V_O
50 kΩ	25 mV
100 kΩ	35 mV
150 kΩ	46 mV
200 kΩ	56 mV

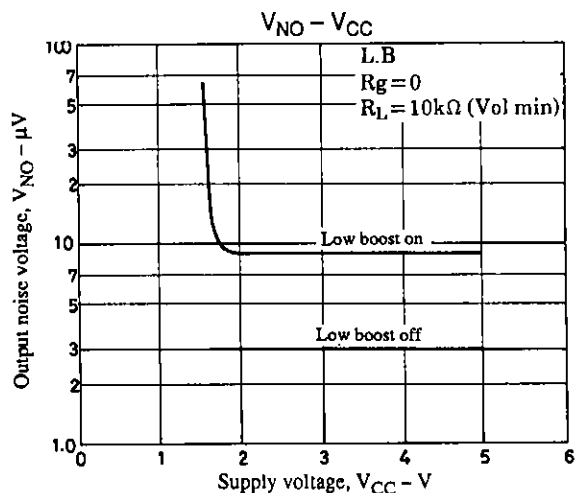
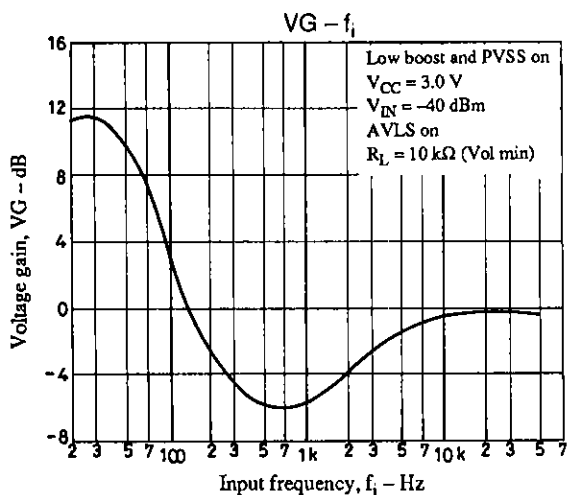
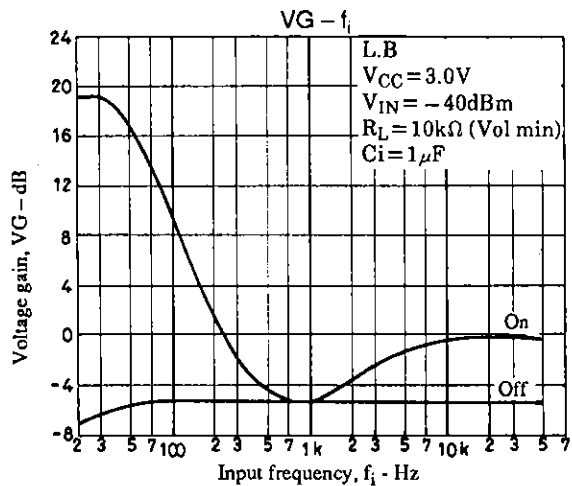
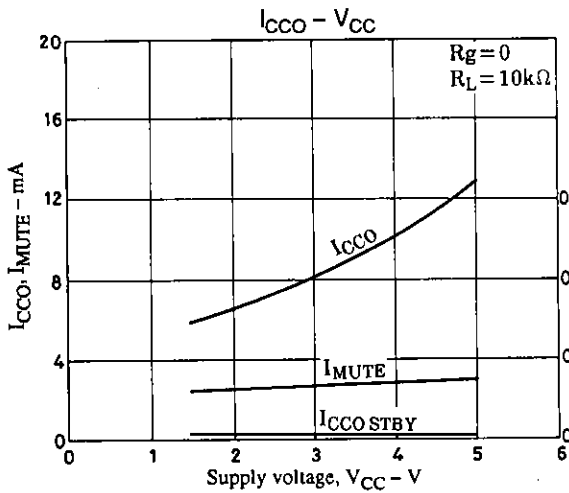

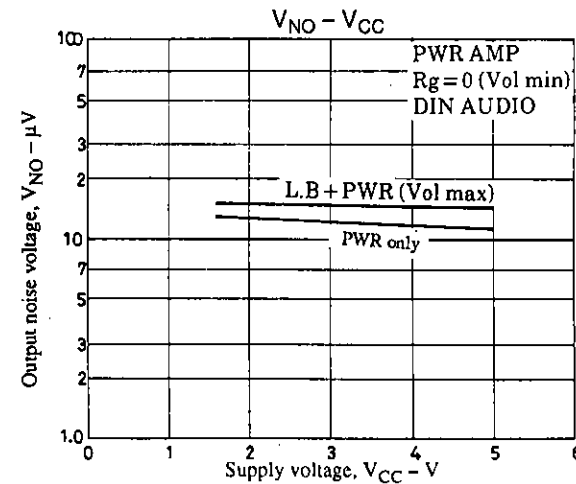
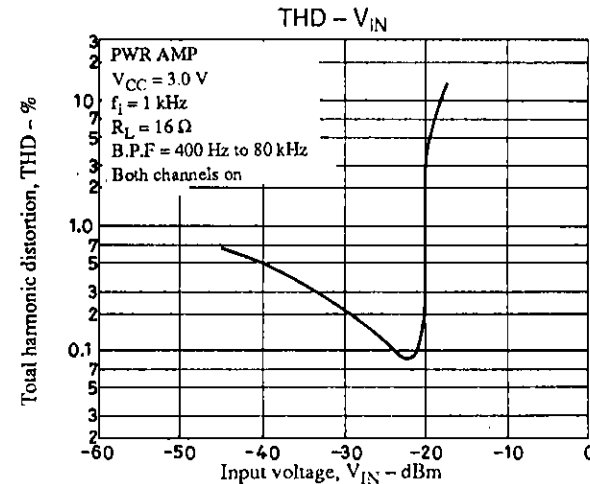
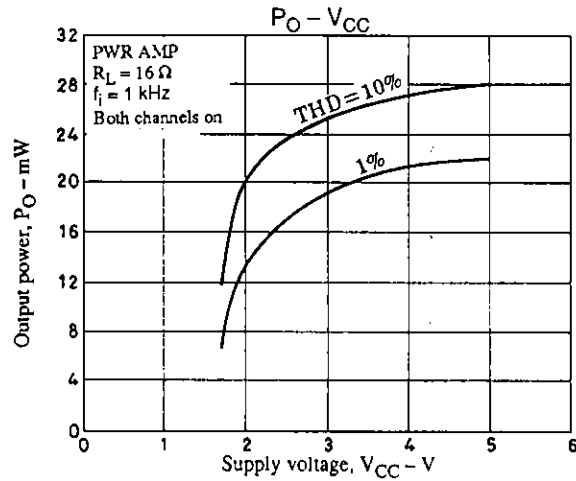
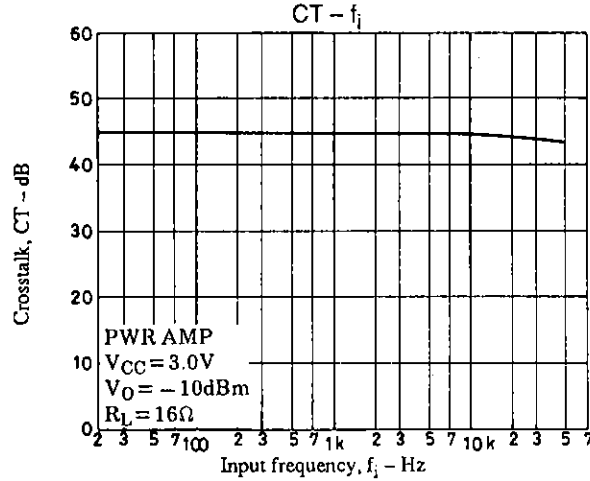
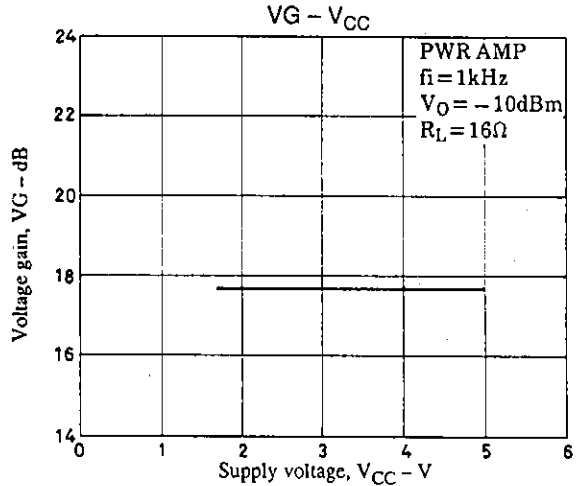
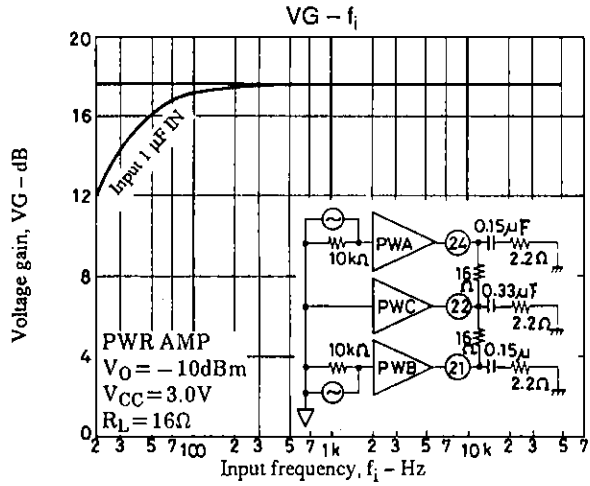
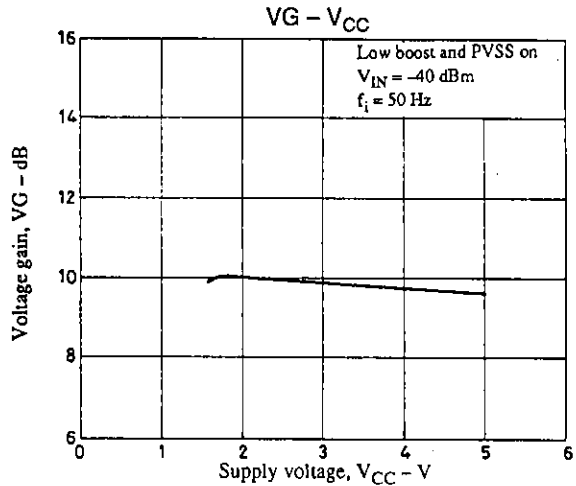
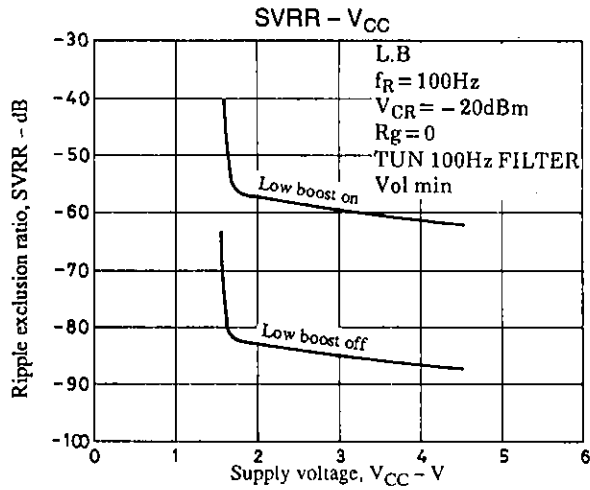

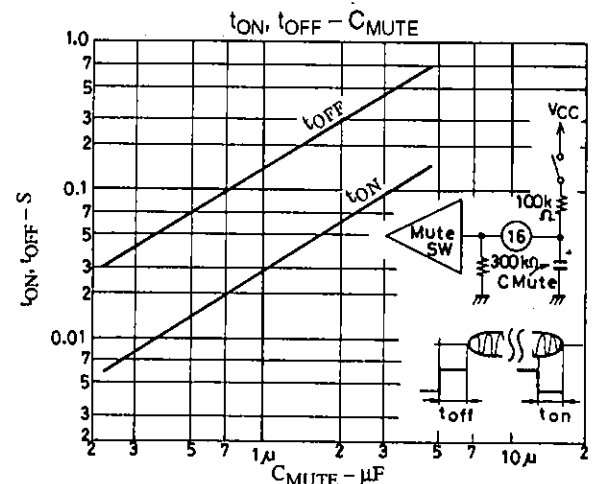
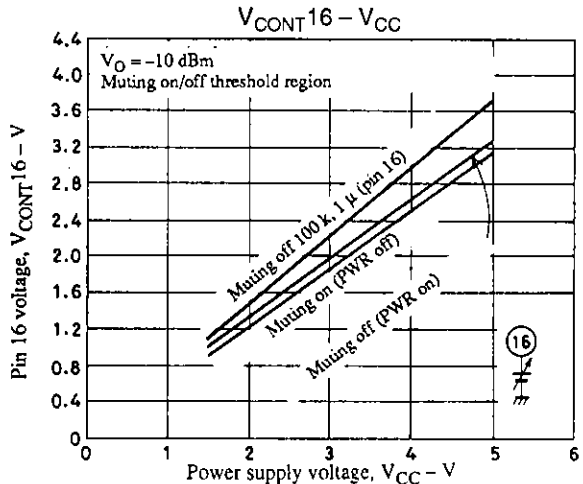
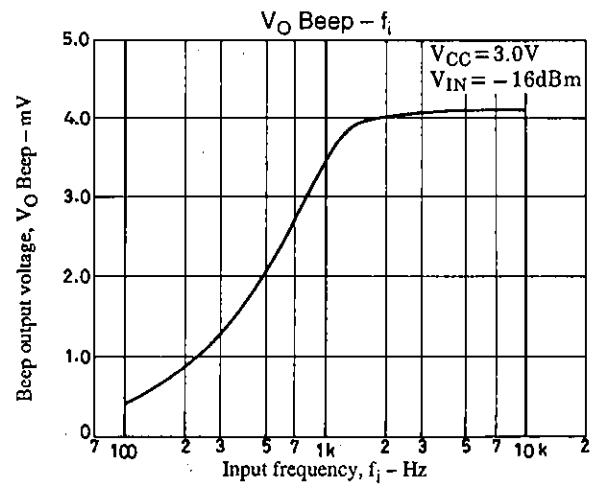
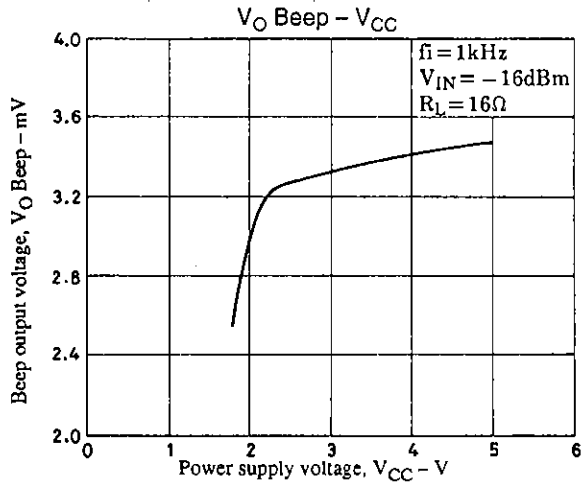
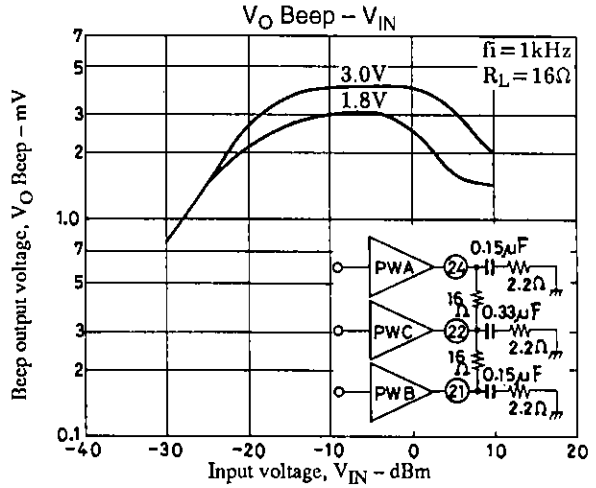
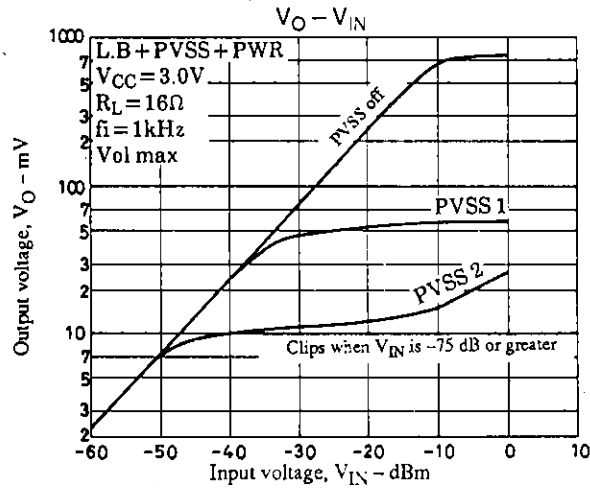
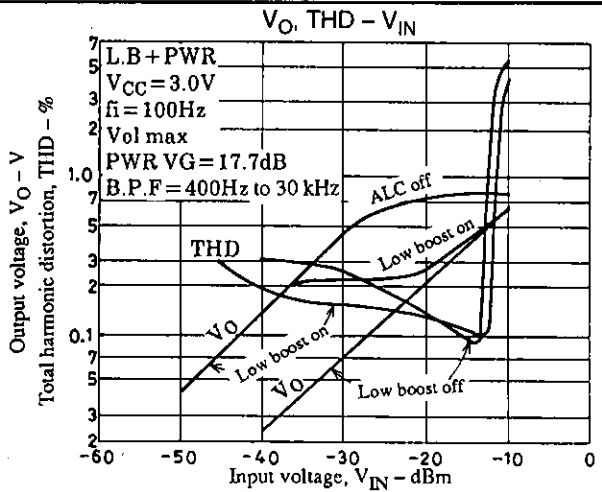
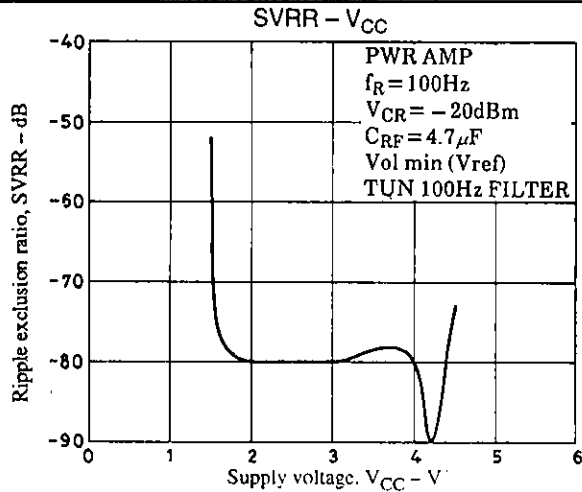

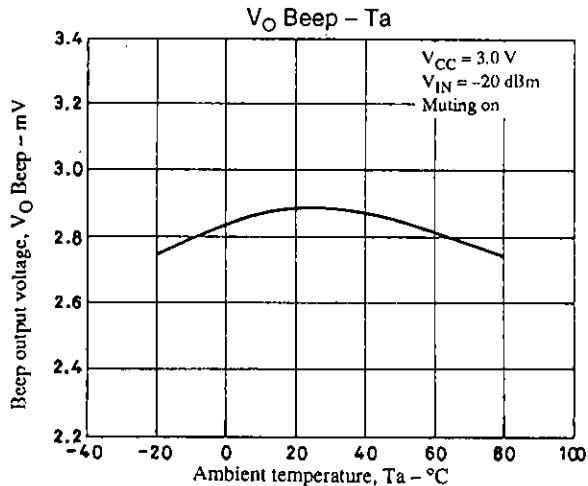
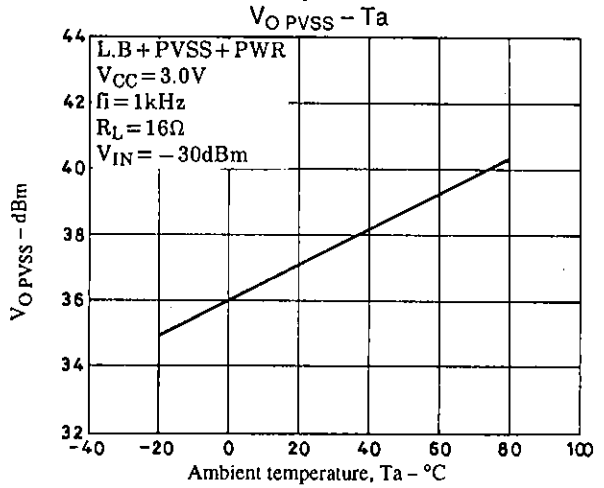
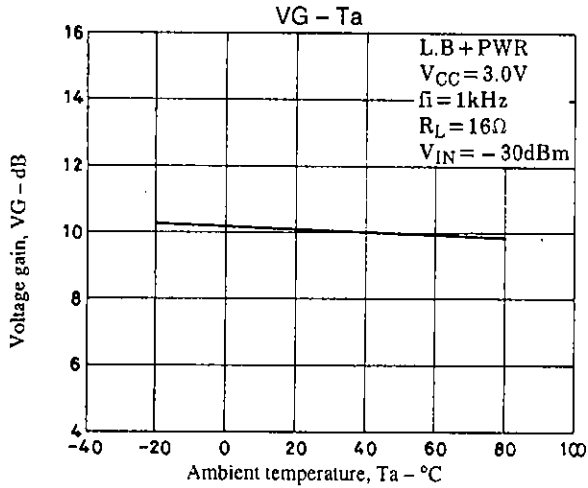
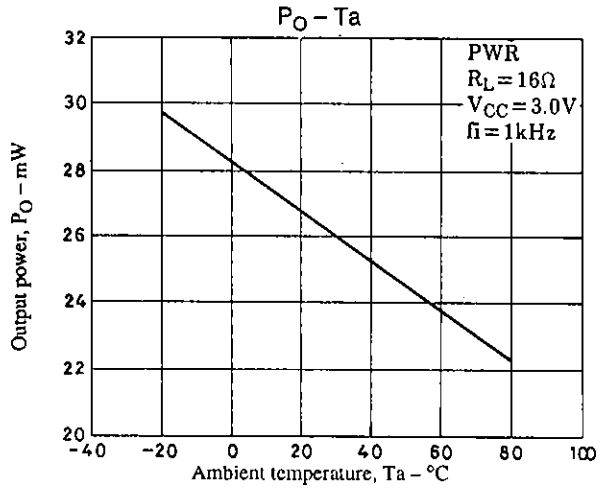
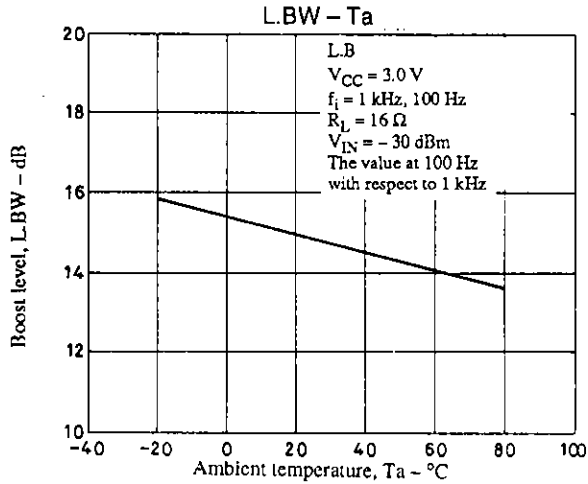
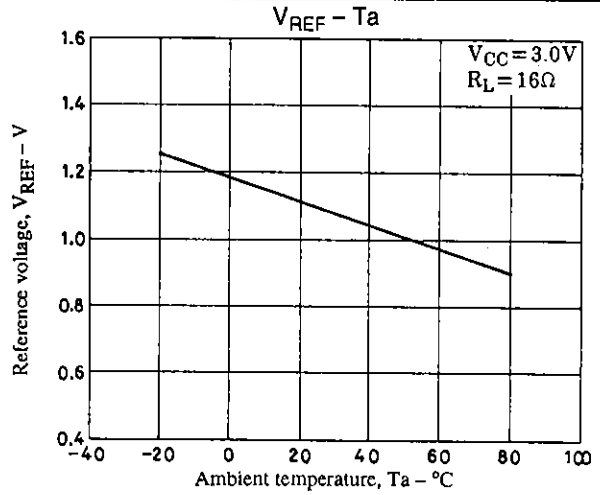
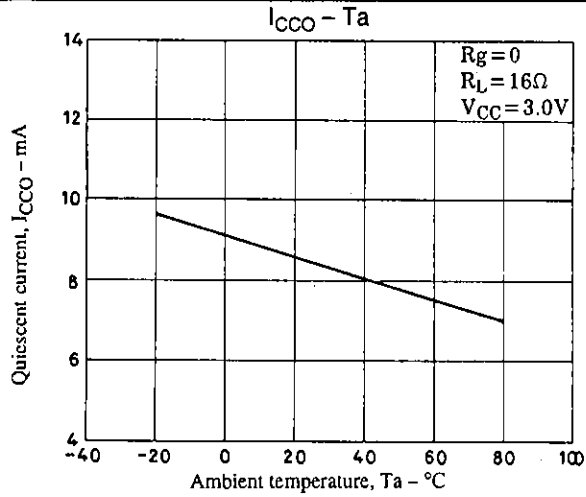

- No products described or contained herein are intended for use in surgical implants, life-support systems, aerospace equipment, nuclear power control systems, vehicles, disaster/crime-prevention equipment and the like, the failure of which may directly or indirectly cause injury, death or property loss.
- Anyone purchasing any products described or contained herein for an above-mentioned use shall:
 - ① Accept full responsibility and indemnify and defend SANYO ELECTRIC CO., LTD., its affiliates, subsidiaries and distributors and all their officers and employees, jointly and severally, against any and all claims and litigation and all damages, cost and expenses associated with such use:
 - ② Not impose any responsibility for any fault or negligence which may be cited in any such claim or litigation on SANYO ELECTRIC CO., LTD., its affiliates, subsidiaries and distributors or any of their officers and employees jointly or severally.
- Information (including circuit diagrams and circuit parameters) herein is for example only; it is not guaranteed for volume production. SANYO believes information herein is accurate and reliable, but no guarantees are made or implied regarding its use or any infringements of intellectual property rights or other rights of third parties.