

TA7256P

DUAL POWER OPERATIONAL AMPLIFIER

The TA7256P is a dual power operational amplifier. It is intended for use especially DC MOTOR positioning system applications such as, Arm Driver (for Audiodisk Players), head or voice coil motor drivers (for Floppy and Winchester Disk Drivers) and any other power driver applications.

FEATURES

- HSIP 10Pin Power Package Capsealed.
- Build-in Over Current Protector.
- Few External Parts Required.
- Output Current Up to 1.0A (PEAK)

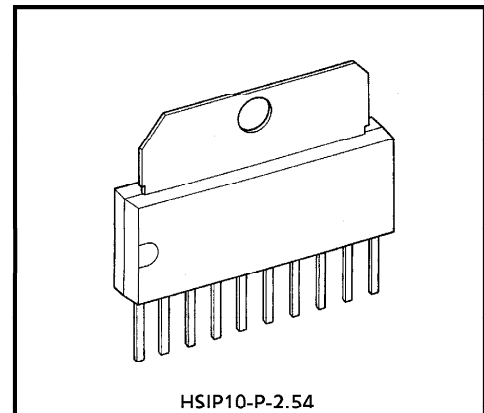

Weight : 2.47g (Typ.)

BLOCK DIAGRAM

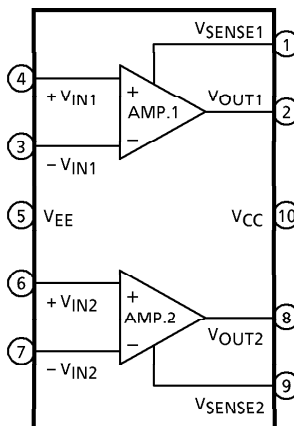

961001EBA2

● TOSHIBA is continually working to improve the quality and the reliability of its products. Nevertheless, semiconductor devices in general can malfunction or fail due to their inherent electrical sensitivity and vulnerability to physical stress. It is the responsibility of the buyer, when utilizing TOSHIBA products, to observe standards of safety, and to avoid situations in which a malfunction or failure of a TOSHIBA product could cause loss of human life, bodily injury or damage to property. In developing your designs, please ensure that TOSHIBA products are used within specified operating ranges as set forth in the most recent products specifications. Also, please keep in mind the precautions and conditions set forth in the TOSHIBA Semiconductor Reliability Handbook.

● The products described in this document are subject to foreign exchange and foreign trade control laws.

● The information contained herein is presented only as a guide for the applications of our products. No responsibility is assumed by TOSHIBA CORPORATION for any infringements of intellectual property or other rights of the third parties which may result from its use. No license is granted by implication or otherwise under any intellectual property or other rights of TOSHIBA CORPORATION or others.

● The information contained herein is subject to change without notice.

PIN FUNCTION

PIN No.	PIN SYMBOL	FUNCTIONAL DESCRIPTION
1	V _{SENSE1}	AMP.1 output current sensing terminal.
2	V _{OUT1}	AMP.1 output terminal.
3	-V _{IN1}	AMP.1 input terminal (-).
4	+V _{IN1}	AMP.1 input terminal (+).
5	V _{EE}	Negative-side power supply terminal.
6	+V _{IN2}	AMP.2 input terminal (+).
7	-V _{IN2}	AMP.2 input terminal (-).
8	V _{OUT2}	AMP.2 output terminal.
9	V _{SENSE2}	AMP.2 output current sensing terminal.
10	V _{CC}	Positive-side power supply terminal.

MAXIMUM RATINGS (Ta = 25°C)

CHARACTERISTIC	SYMBOL	RATING	UNIT
Supply Voltage	V _{CC} , V _{EE}	± 18	V
Output Current	I _O (AVE.)	0.5	A
Power Dissipation	P _D (Note)	12.5	W
Operating Temperature	T _{opr}	- 30~75	°C
Storage Temperature	T _{stg}	- 55~150	°C

(Note) T_c = 25°CELECTRICAL CHARACTERISTICS (Unless otherwise specified, V_{CC} = 15V, V_{EE} = -15V, Ta = 25°C)

CHARACTERISTIC	SYMBOL	TEST CIR-CUIT	TEST CONDITION	MIN.	TYP.	MAX.	UNIT
Quiescent Current	I _{CC}	—	—	—	10	20	mA
Input Off Set Current	I _{IO}	—	—	—	10	200	nA
Input Bias Current	I _I	—	—	—	100	700	nA
Input Off Set Voltage	V _{IO}	—	—	—	2	6	mV
Output Voltage Swing	Upper	—	R _L = 33Ω	12	13.0	—	V
	Lower			V _{OH}	V _{OL}	- 12	
Open Loop Gain	G _{VO}	—	—	—	100	—	dB
Input Common Mode Voltage Range	CMR	—	—	± 12	± 14	—	
Common Mode Rejection Ratio	CMRR	—	—	70	90	—	dB
Supply Voltage Rejection Ratio	SVRR	—	—	—	50	150	μV/V
Band Width	f _T	—	Open loop	—	1.0	—	MHz
Slew Rate	SR	—	G _V = 0, R _L = 33Ω R = 10Ω, C = 0.1μF	—	0.15	—	V/μs
Short Circuit Current	I _{SC}	—	R _{SC} = 2.2Ω	—	0.35	—	A
Cross Talk	C _T	—	R _L = 33Ω, V _{OUT} = 1V _{p-p}	—	60	—	dB

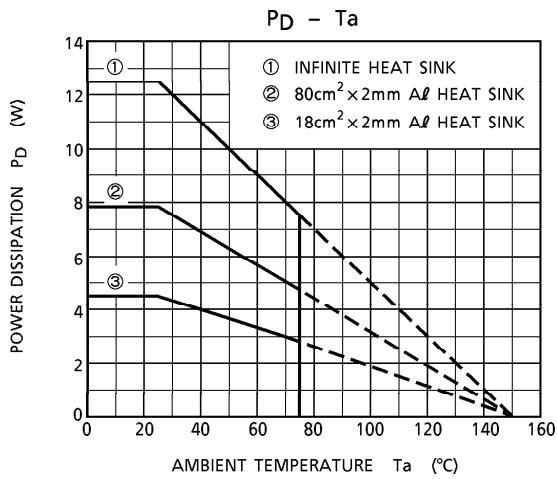

APPLICATION CIRCUIT 1

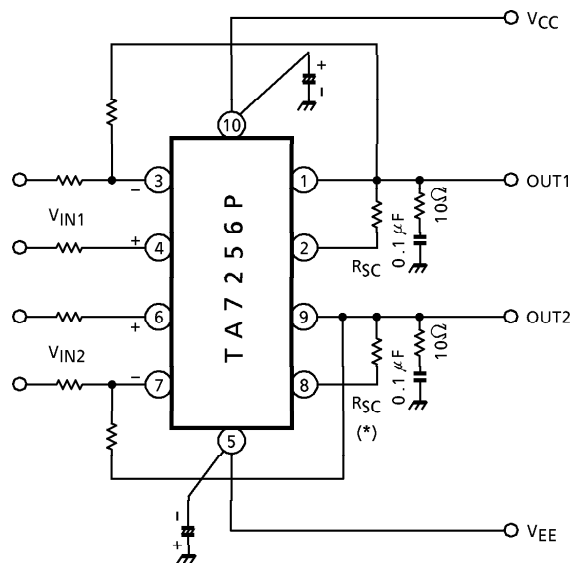

(*)
$$I_{SC} \doteq \frac{0.77 (V)}{R_{SC} (\Omega)} (A)$$

(Note) Utmost care is necessary in the design of the output line, V_{CC} and GND line since IC may be destroyed due to short-circuit between outputs, air contamination fault, or fault by improper grounding.

APPLICATION CIRCUIT 2 (Compact disk player use actuator system)

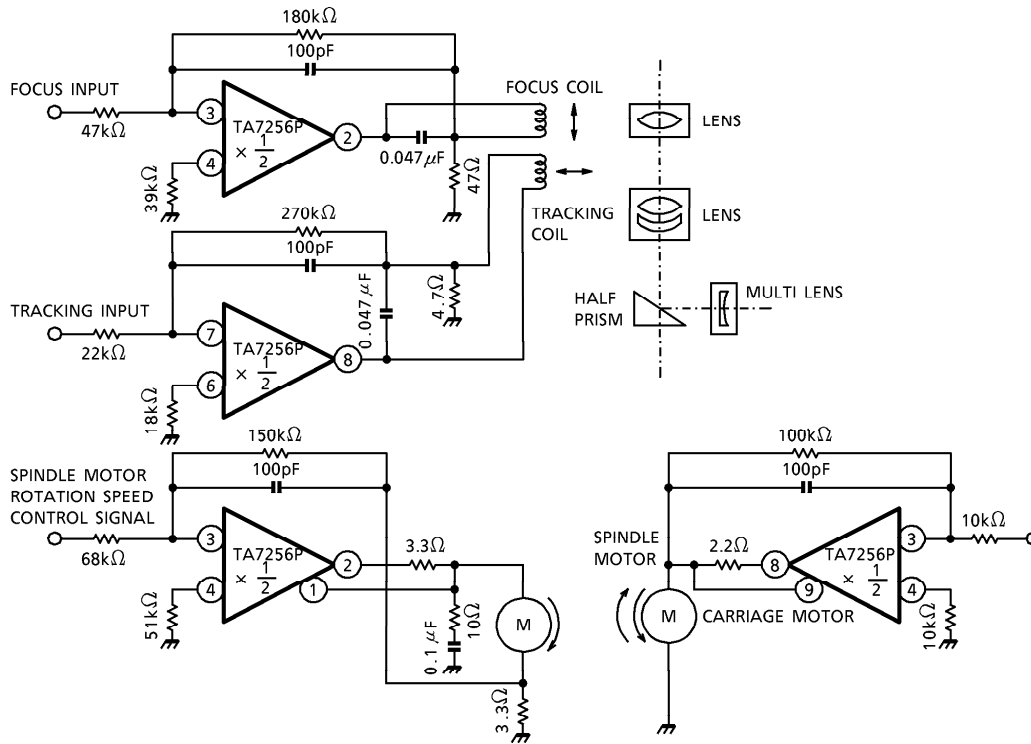

OUTLINE DRAWING
HSIP10-P-2.54

Unit : mm

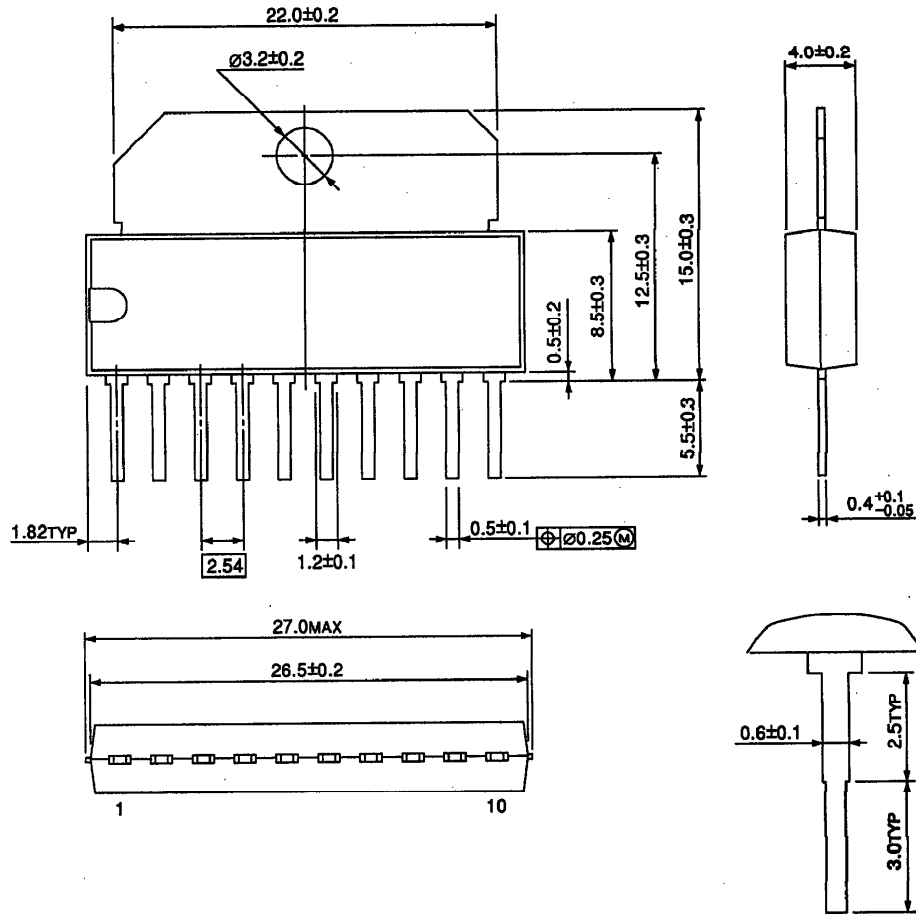

Weight : 2.47g (Typ.)