

<b>SANYO</b>	No. 3936 A.	<b>LA7375</b>
<b>Recording and Playback Amplifier for VHS Video Recorders</b>		

**Overview**

The LA7375 is a recording and playback amplifier for VHS-format video tape recorders. It features a two-channel playback amplifier and a single-channel recording amplifier, making it ideal for standard-play mode recorders.

The LA7375 operates from a 5V supply and is available in 16-pin DIPs.

**Features**

- Two-channel playback amplifier
- Single-channel recording amplifier
- RF envelope detector for automatic tracking
- Constant-current output, high stability recording amplifier
- Automatic gain control
- 5V supply
- 16-pin DIP

**Package Dimensions**

Unit: mm

3006B-DIP16

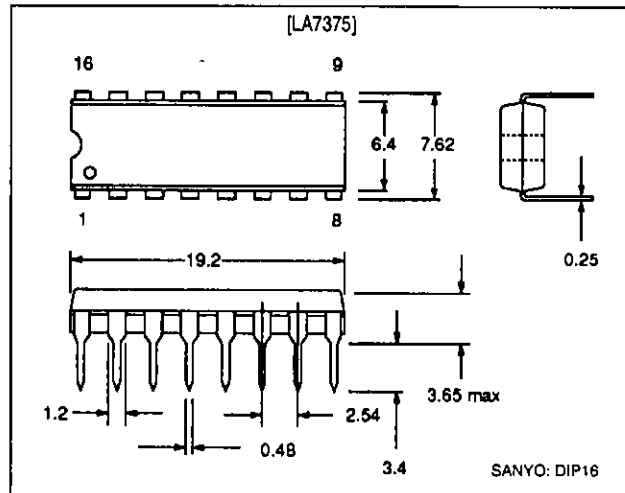

## Specifications

### Maximum Ratings at $T_a = 25^\circ\text{C}$

Parameter	Symbol	Conditions	Ratings	Unit
Maximum supply voltage	$V_{CC}$		7	V
Allowable power dissipation	$P_D$ max	$T_a = 65^\circ\text{C}$	650	mW
Operating temperature	$T_{opr}$		-10 to +65	$^\circ\text{C}$
Storage temperature	$T_{stg}$		-40 to +150	$^\circ\text{C}$

### Operating Conditions at $T_a = 25^\circ\text{C}$

Parameter	Symbol	Conditions	Ratings	Unit
Supply voltage	$V_{CC}$		5	V
Supply voltage range	$V_{CC\ op}$		4.75 to 5.5	V

### Operating Characteristics at $T_a = 25^\circ\text{C}$

#### Playback Mode with SW3 = OFF

Parameter	Symbol	Conditions	Ratings			Unit
			min	typ	max	
Supply current	$I_{CCP}$		23	28	33	mA
Channel 1 voltage gain	$G_{VP1}$	$V_i = 38\text{mVp-p}$ , $f = 1\text{MHz}$	57	60	63	dB
Channel 2 voltage gain	$G_{VP2}$		57	60	63	dB
Gain differential	$\Delta G_{VP}$	$G_{VP1} - G_{VP2}$	-1	0	+1	dB
Input conversion rms noise voltage	$V_{NI}$	1.1MHz lowpass filter	-	1.1	1.5	$\mu\text{V}$
Frequency response	$\Delta V_{FP}$	$V_i = 38\text{mVp-p}$ , $f = 1$ to 7MHz	-3.5	0	-	dB
Second-harmonic distortion	$V_{HDP}$	$V_i = 38\text{mVp-p}$ , $f = 4\text{MHz}$	-	-40	-35	dB
Maximum output level	$V_{OMP}$	$f = 1\text{kHz}$ , -30dB harmonic distortion	0.8	1.0	-	Vp-p
Crosstalk	$V_{CR}$	$V_i = 38\text{mVp-p}$ , $f = 4\text{MHz}$ , 8.2 $\mu\text{H}$ input inductor short-circuited	-	-40	-35	dB
Output DC offset voltage between channels	$\Delta V_{ODC}$		-350	0	+350	mV
AGC input level	$\Delta AGC$	$f = 4\text{MHz}$ , $TP4 = 250\text{mVp-p}$	300	330	360	mVp-p
AGC second-harmonic distortion	$V_{HDAGC}$	$V_i = 38\text{mVp-p}$ , $f = 4\text{MHz}$	-	-40	-35	dB
AGC control level	$V_{AGC}$	$f = 4\text{MHz}$ , $T4 = 500\text{mVp-p}$	-	1.0	1.5	dB
		$f = 4\text{MHz}$ , $T4 = 125\text{mVp-p}$	-1.2	-0.7	-	
Envelope detector quiescent output voltage	$V_{ENVQ}$	T12 quiescent, no input	0.47	0.52	0.57	V
Envelope detector output	$V_{ENV}$	$f = 4\text{MHz}$ , $T4 = 300\text{mVp-p}$	2.0	2.25	2.5	V
		$f = 4\text{MHz}$ , $T4 = 500\text{mVp-p}$	2.9	3.2	3.5	
		$f = 3\text{MHz}$ , $T4 = 300\text{mVp-p}$	1.65	1.9	2.15	
		$f = 5\text{MHz}$ , $T4 = 300\text{mVp-p}$	2.0	2.3	2.6	
Playback-ON switch ON resistance	$R_{PON}$	Measured with 1mA and 2mA DC inputs.	-	6	10	$\Omega$
SW1 threshold level	$SW_{RF1}$	Channel 1 to 2	1.2	-	1.8	V
		Channel 2 to 1	0	-	0.8	
SW2 threshold level	$SW_{RF2}$	Channel 1 to 2	3.2	-	4.0	V
		Channel 2 to 1	2.2	-	2.8	

## Recording Mode with SW3 = ON

Parameter	Symbol	Conditions	Ratings			Unit
			min	typ	max	
Supply current	$I_{CCR}$		50	55	60	mA
Voltage gain	$G_{VR}$	$V_i = 150\text{mVp-p}$ , $f = 4\text{MHz}$	-3.5	-1.5	+0.5	dB
Frequency response	$\Delta V_{FR}$	$V_i = 150\text{mVp-p}$ , $f = 1$ to $7\text{MHz}$	-2	0	-	dB
Second-harmonic distortion	$V_{HDR}$	$f = 4\text{MHz}$ , $V_o = 15\text{mVp-p}$	-	-45	-40	dB
Maximum output level	$V_{OMP}$	$f = 4\text{MHz}$ , -40dB harmonic distortion	15	20	-	mVp-p
Muting attenuation	$V_{MR}$	$V_i = 150\text{mVp-p}$ , $f = 4\text{MHz}$	-	-45	-40	dB
Intermodulation distortion	$V_{CY}$	$f_{(T8Y)} = 4\text{MHz}$ , $f_{(T8C)} = 629\text{kHz}$ , $T15A = 150\text{mVp-p}$ , $T15 = 40\text{mVp-p}$	-	-45	-40	dB
Luminance and chrominance mixer voltage gain	$G_{MIX}$	$V_i = 150\text{mVp-p}$ , $f = 4\text{MHz}$	9	11	13	dB
REC switch threshold level	$SW_{REC}$		3.9	-	5.0	V
REC MUTE threshold level	$SW_{MUTE}$		2.2	-	4.0	V

## Measurement Conditions

## Playback Mode

Parameter	Channel	Test points		Switch positions	
		Input	Output	SW30	Mute
Supply current		T1		1	
Voltage gain, frequency response, harmonic distortion, output level and crosstalk	1	T16	T4	1	
	2	T12	T4	2	
Input conversion rms noise level	1, 2		T4	1	
Output DC offset		PB CHROMA		1 to 2	
AGC input level, AGC harmonic distortion and AGC control voltage		T16	T6	1	
Envelope detector quiescent current			T2	1	
Envelope detector output voltages		T16	T2	1	
Playback-ON switch ON resistance			T11		
RF SW1 threshold		T3			1
RF SW2 threshold		T3			2

## Recording Mode

Parameter	Test points		Switch positions	
	Input	Output	SW30	Mute
Supply current	T1			1
Voltage gain, frequency response, harmonic distortion and output level	T8Y	T15A, T15		1
Muting attenuation	T8Y	T15A, T15		2
Intermodulation distortion	T8Y, T8C	T15A, T15		1
Luminance and chrominance mixer gain	T8Y	T9		1
REC switch threshold	T3			1
REC MUTE switch threshold	T3			2

Pin Assignment

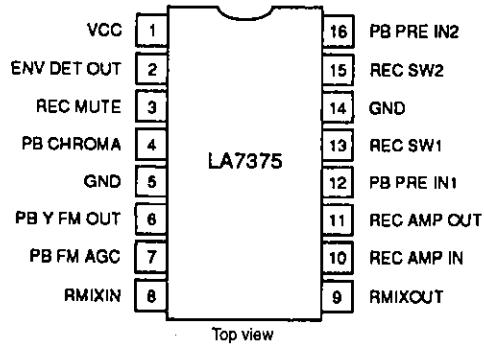

Block Diagram

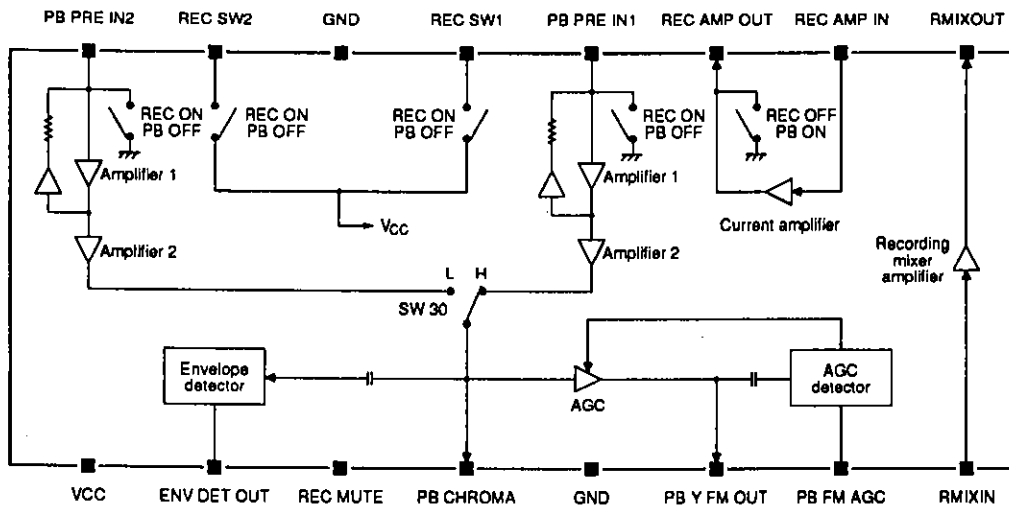

### AC Measurement Circuit

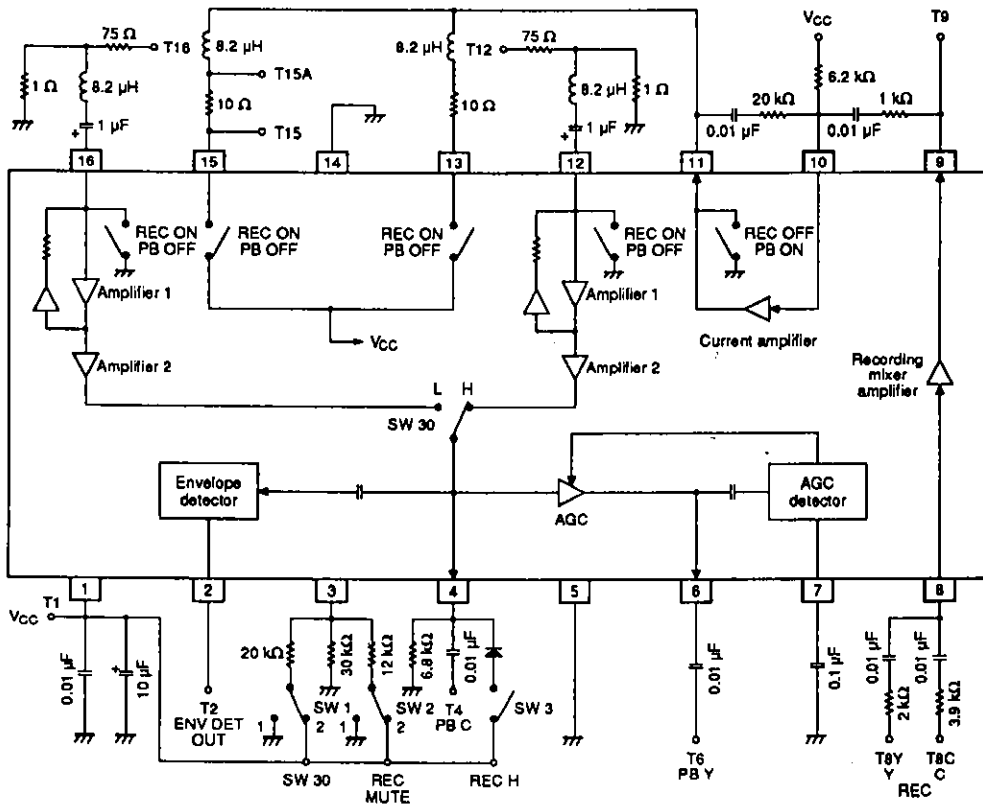

Note that the SW30 switch is in the L position when the voltage on pin 3 is 0 to 1V (muting OFF) or 2 to 3V (muting ON), and in the H position when the voltage on pin 3 is 1 to 2V (muting OFF) or 3 to 4V (muting ON).

### Typical Application

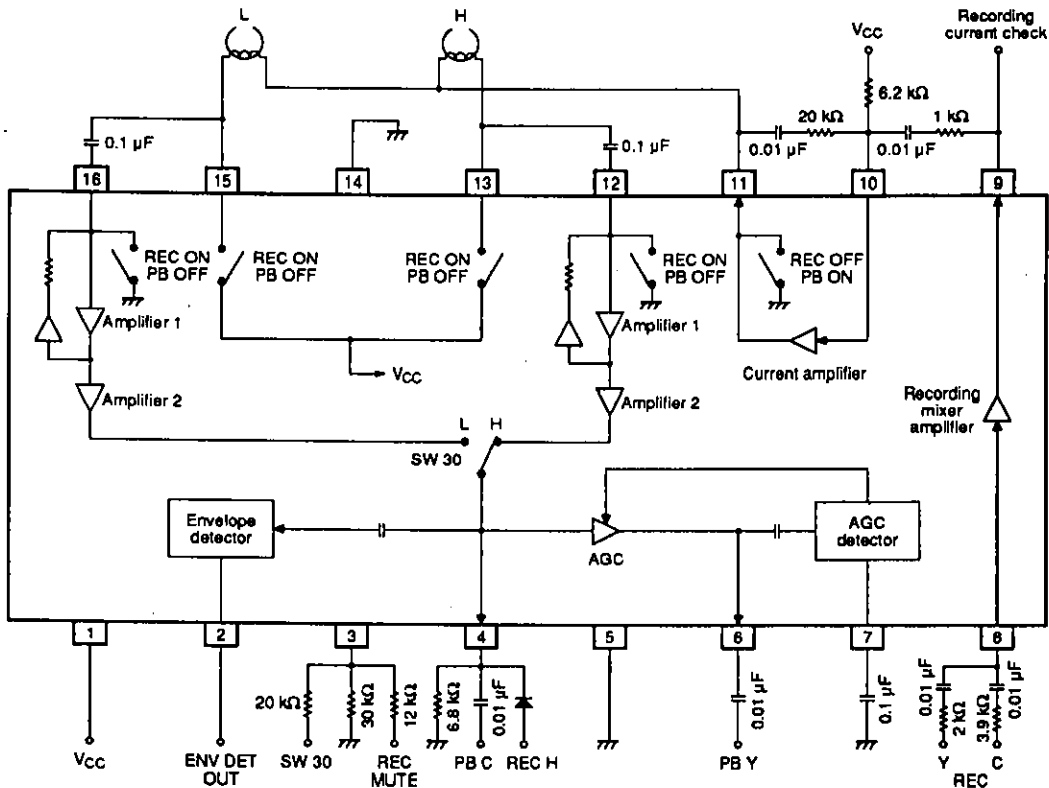

Pin Functions

Number	Name	Equivalent circuit	Function
1	VCC		5V supply
2	ENV DET OUT		Playback-mode envelope detector output. Nominal voltages are 0.5V (PB with no signal) and 0V (REC).
3	REC MUTE		Muting control and playback SW30 switch control input
4	PB CHROMA		Playback chrominance output. Nominal voltages are 2.0V (PB) and > 3.8V (REC).
5	GND		Ground
6	PB Y FM OUT		Luminance FM output. Nominal voltages are 2.5V (PB) and 4.0V (REC).
7	PB FM AGC		Playback AGC detector output. Nominal voltages are 1.5V (PB) and 0V (REC).
8	RMIXIN		Recording-mode mixer amplifier input. Nominal voltages are 2.1V (PB) and 1.65V (REC). Gain is 11dB when R is 2kΩ, and 6dB when R is 3.9kΩ.
9	RMIXOUT		Recording-mode mixer amplifier output. Nominal voltages are 4.1V (PB) and 1.8V (REC).

LA7375

Number	Name	Equivalent circuit	Function
10	REC AMP IN		Recording-mode current amplifier input. Nominal voltages are 1.77V (PB) and 1.85V (REC).
11	REC AMP OUT		Recording-mode current amplifier output. Nominal voltages are 0V (PB) and 4.2V (REC). Switching transistor ON resistance is 5Ω.
12	PB PRE IN1		Playback-mode preamplifier input. Nominal voltages are 0.7V (PB) and 0V (REC). Low-noise input transistor.
13	REC SW1		Recording-mode switches. Nominal voltages are 0V (PB) and 4.2V (REC).
15	REC SW2		
14	GND		Preamplifier ground
16	PB PRE IN2		Playback-mode preamplifier input. Nominal voltages are 0.7V (PB) and 0V (REC). Low-noise input transistor.

- No products described or contained herein are intended for use in surgical implants, life-support systems, aerospace equipment, nuclear power control systems, vehicles, disaster/crime-prevention equipment and the like, the failure of which may directly or indirectly cause injury, death or property loss.
- Anyone purchasing any products described or contained herein for an above-mentioned use shall:
  - ① Accept full responsibility and indemnity and defend SANYO ELECTRIC CO., LTD., its affiliates, subsidiaries and distributors and all their officers and employees, jointly and severally, against any and all claims and litigation and all damages, cost and expenses associated with such use:
  - ② Not impose any responsibility for any fault or negligence which may be cited in any such claim or litigation on SANYO ELECTRIC CO., LTD., its affiliates, subsidiaries and distributors or any of their officers and employees, jointly or severally.
- Information (including circuit diagrams and circuit parameters) herein is for example only; it is not guaranteed for volume production. SANYO believes information herein is accurate and reliable, but no guarantees are made or implied regarding its use or any infringements of intellectual property rights or other rights of third parties.

This catalog provides information as of April, 1995. Specifications and information herein are subject to change without notice.